

CLEVER

..... a c o u s t i c s

www.cleveracoustics.co.uk

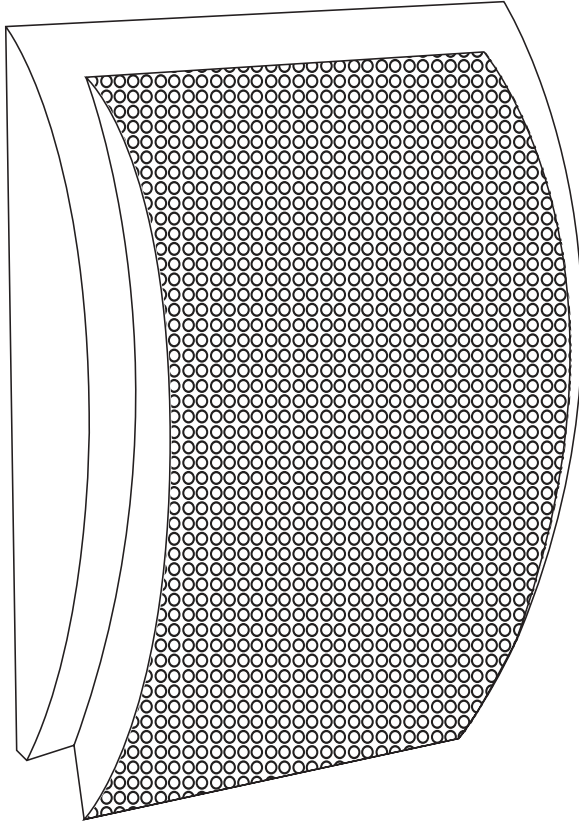

CSW 56 - 100V 6" 6W
Wall Mount Loudspeaker



Order code: CRSP16

USER MANUAL

.....

WARNING



**FOR YOUR OWN SAFETY, PLEASE READ THIS USER MANUAL CAREFULLY
BEFORE YOUR INITIAL START-UP!**

	<p>CAUTION! INPUT VOLTAGE OF 70-100V</p>	
---	--	---

SAFETY INSTRUCTIONS

Every person involved with the installation, operation & maintenance of this equipment should:

- Be competent
- Follow the instructions of this manual

	<p>CAUTION! TAKE CARE USING THIS EQUIPMENT! HIGH VOLTAGE-RISK OF ELECTRIC SHOCK!!</p>	
---	---	---

Before your initial start-up, please make sure that there is no damage caused during transportation. Should there be any, consult your dealer and do not use the equipment.

To maintain the equipment in good working condition and to ensure safe operation, it is necessary for the user to follow the safety instructions and warning notes written in this manual.

Please note that damages caused by user modifications to this equipment are not subject to warranty.

IMPORTANT:

The manufacturer will not accept liability for any resulting damages caused by the non-observance of this manual or any unauthorised modification to the equipment.

- Never let the loudspeaker cable come into contact with other cables. Handle the loudspeaker cable and all mains voltage connections with particular caution!
- Never remove warning or informative labels from the equipment.
- Do not open the equipment and do not modify the equipment.
- Do not switch the equipment on and off in short intervals, as this will reduce the system's life.
- Do not expose to flammable sources or gases.
- Make sure that the loudspeaker-cable is never crimped or damaged. Check the equipment and the speaker-cable periodically.
- If the equipment is dropped or damaged, disconnect the supply immediately. Have a qualified engineer inspect the equipment before operating again.
- If your product fails to function correctly, discontinue use immediately. Pack the unit securely (preferably in the original packing material), and return it to your Prolight dealer for service.
- Repairs, servicing and power connection must only be carried out by a qualified technician. THIS UNIT CONTAINS NO USER SERVICEABLE PARTS.
- WARRANTY; One year from date of purchase.

OPERATING DETERMINATIONS

If this equipment is operated in any other way, than those described in this manual, the product may suffer damage and the warranty becomes void.

Incorrect operation may lead to danger e.g.: short-circuit, burns, electric shocks etc.

Do not endanger your own safety and the safety of others!
Incorrect installation or use can cause serious damage to people and property.

The 100V wall mount loudspeaker is designed specifically for use in permanent audio installations, where reliability and premium sound quality are a must. Highly rugged construction and high efficiency design make this projection speaker perfect for continuous duty applications.

This wall mount loudspeaker is warranted from defects for one year from the date of purchase. Should your wall mount loudspeaker require service, either within or beyond that warranty period, please contact your Prolight Dealer.

Features:

- Built-in 100V/70V transformer
- Wall mount type loudspeaker
- 2-way design delivers wide frequency response
- Three power taps (70V/100V)
- Metal grille and ABS enclosure
- Spring terminals for simple installation
- Fast, easy wall mount installation

Specifications	
Input:	100V, 70V
Power taps @ 100V:	1.5W, 3W, 6W
Power taps @ 70V:	0.75W, 1.5W, 3W
Impedance:	6.7kΩ, 3.3kΩ, 1.7kΩ
Sensitivity (1W/1m):	90dB (±3dB)
Maximum SPL (Rated W/1m):	98dB
Frequency response:	90Hz-18kHz
Drivers:	5" LF, 1" HF
Connections:	Spring terminals
Dimensions:	285 x 200 x 85mm
Weight:	1.3kg
Order Reference:	CRSP16

Overview:

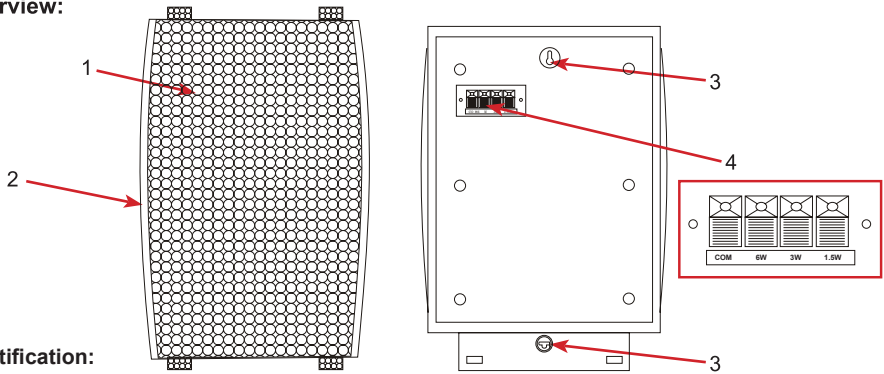

Identification:

1. Loudspeaker grill

2. Loudspeaker housing

3. Key hole mounting points- Use these mounting bracket to attach the speaker onto the wall.

4. Loudspeaker cable - Use these sockets to connect to the mixer amplifier.

Wall Installation

The wall mount loudspeaker is designed to be installed onto a wall.

Before installing the speaker, make sure that the installation area can hold a minimum point load of 10 times the installations weight.(e.g.12kg x 10 = 120kg point load).

The durability of the installation depends very much on the material used at the installation area (building material), such as wood, concrete and brick etc.

This is why the fixing material must be chosen to suit the ceiling material. Always ask a specialist for the correct plug/screw combination indicating the maximum load and building material.

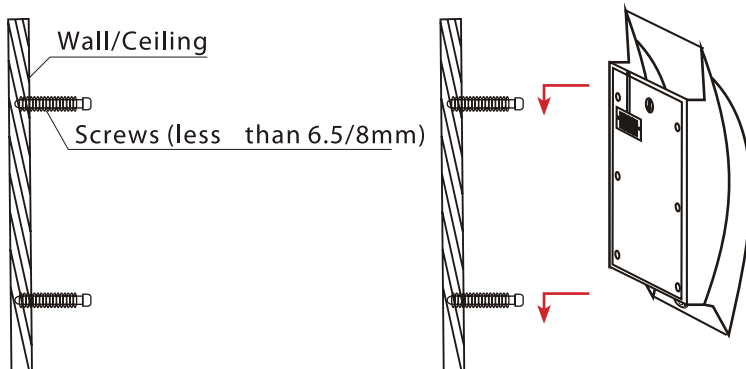

Connections:

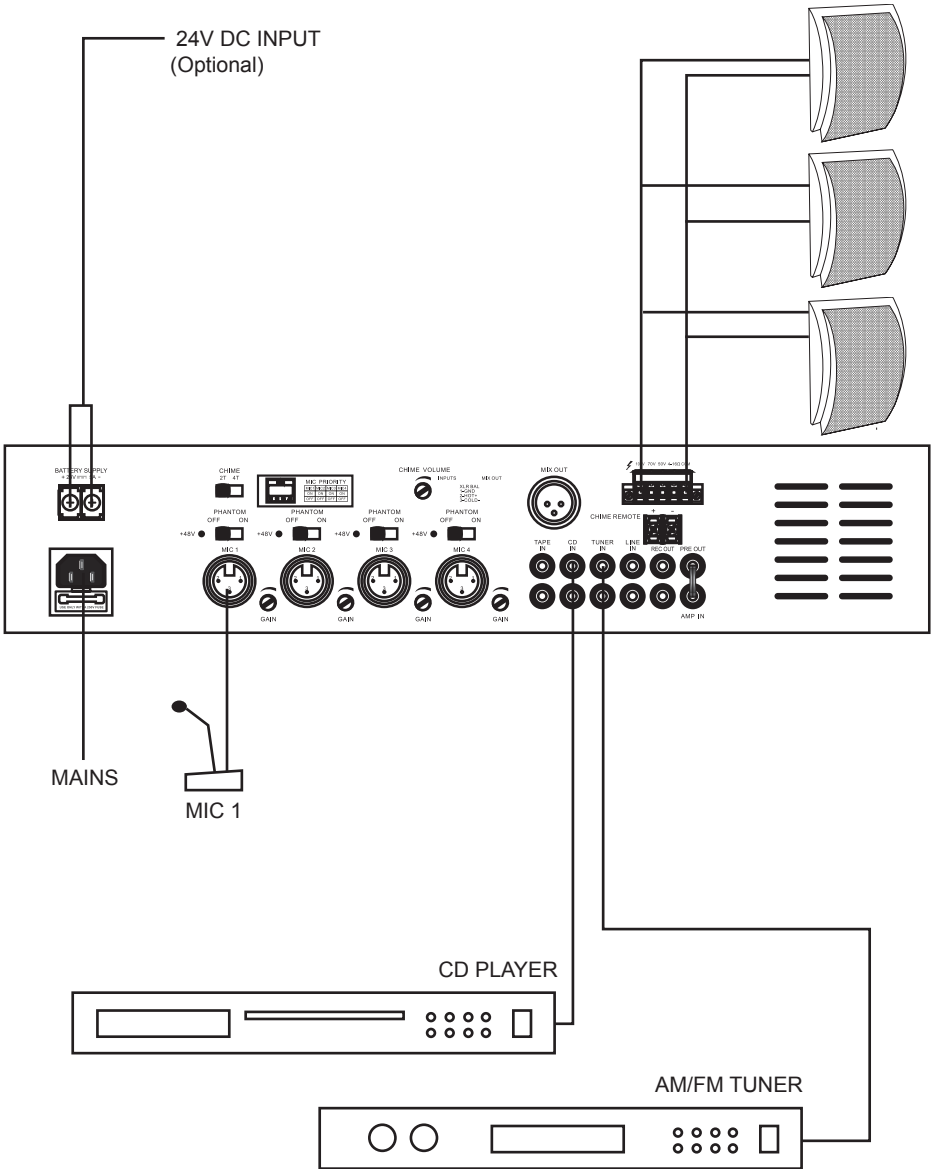

Dispersion characteristics:

CSW 56

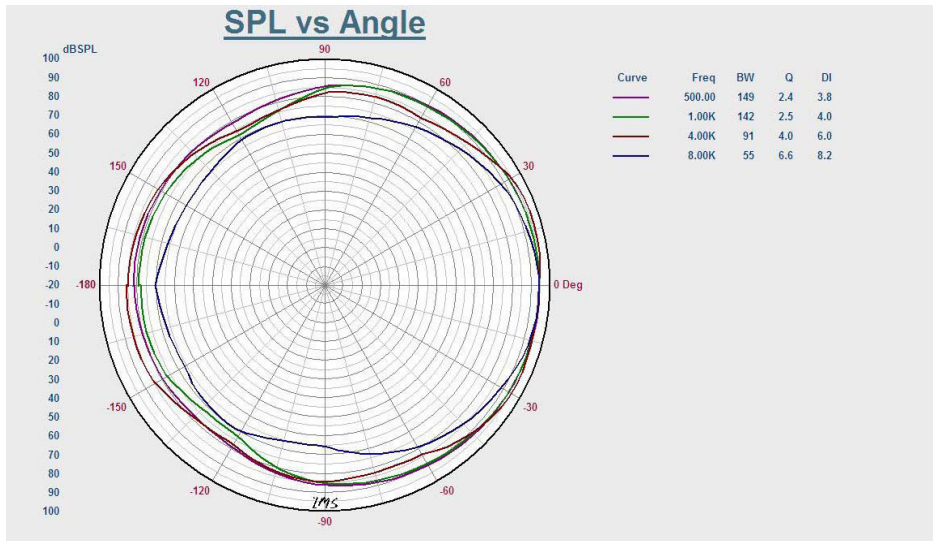



**CAUTION - DANGER TO LIFE
SWITCH OFF AMPLIFIER AND DISCONNECT
THE SPEAKER BEFORE
STARTING MAINTENANCE**



Cleaning and Maintenance

We recommend a frequent cleaning of the product. Please use a soft lint free and moistened cloth. Never use alcohol or solvents.

There are no serviceable parts inside the product except for the fuse. Maintenance and service operations are only to be carried out by authorised dealers.

English



Correct Disposal of This Product (Waste Electrical & Electronic Equipment)

(Applicable in the European Union and other European countries with separate collection systems)

This marking shown on the product or its literature, indicates that it should not be disposed with other household wastes at the end of its working life. To prevent possible harm to the environment or human health from uncontrolled waste disposal, please separate this from other types of wastes and recycle it responsibly to promote the sustainable reuse of material resources.

Household users should contact either the retailer where they purchased this product, or their local government office, for details of where and how they can take this item for environmentally safe recycling.

Business users should contact their supplier and check the terms and conditions of the purchase contract. This product should not be mixed with other commercial wastes for disposal.

CLEVER
a c o u s t i c s

www.cleveracoustics.co.uk

.....