

**ACME<sup>®</sup>**

# LED SCAN 25

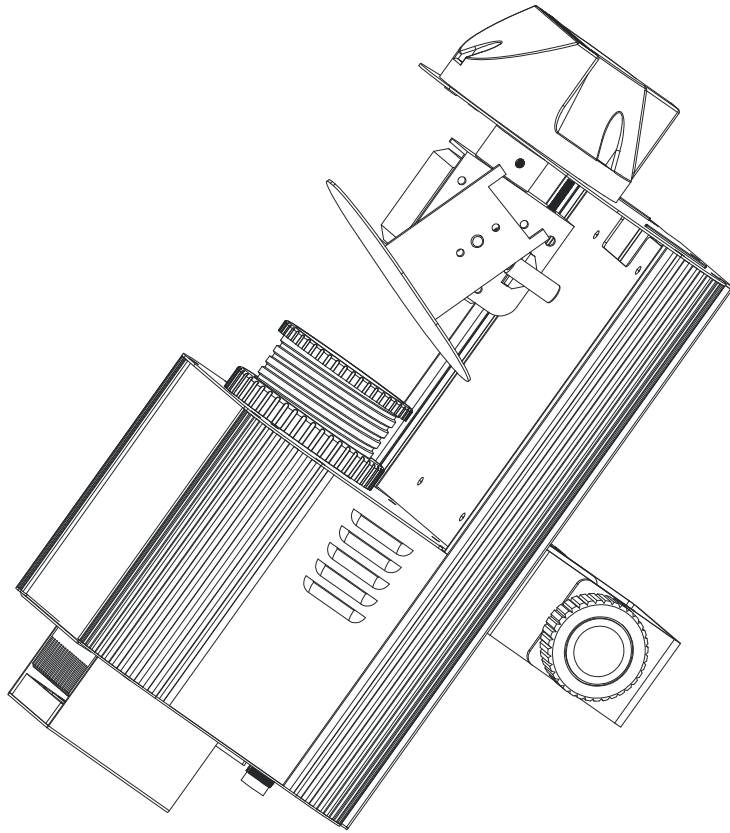

**LED-SC25**

**User Manual**

Please read the instructions carefully before use

# CONTENTS

1. Safety Instructions.....	2
2. Technical Specifications.....	3
3. How To Control The Unit.....	4
3.1 Control Panel.....	4
3.2 Master/Slave Operation.....	5
3.3 Easy CA-8 Controller.....	5
3.4 Universal DMX Controller.....	6
4. DMX 512 Configuration.....	7
5. DMX 512 Connection.....	7
6. Troubleshooting.....	8
7. Cleaning and Maintenance.....	9

## 1. Safety Instructions



### Warning

Please read the instructions carefully as they include important information about installation, operation and maintenance.

Please keep this User Manual for future consultation. If you sell the unit to another user, be sure that they also receive this instruction booklet.

- Unpack and check carefully there is no transportation damage before using the unit.
- Before operating, ensure that the voltage and frequency of power supply match the power requirements of the unit.
- It's important to ground the yellow/green conductor to earth in order to avoid electric shock.
- The unit is for indoor use only. Use only in a dry location.
- The unit must be installed in a location with adequate ventilation, at least 50cm from adjacent surfaces. Be sure that no ventilation slots are blocked.
- Disconnect main power before replacement or servicing.
- Make sure there are no flammable materials close to the unit while operating as it is a fire hazard.
- Use safety cables when installing this unit.
- Maximum ambient temperature is  $T_a$ : 40 degrees C. DO NOT operate it where the temperature is higher than this.
- Turn off the power and allow about 5 minutes for the unit to cool down before servicing.
- In the event of a serious operating problem, stop using the unit immediately. Never try to repair the unit by yourself. Repairs carried out by unskilled people can lead to damage or malfunction. Please contact the nearest authorized technical assistance center. Always use the same type spare parts.
- DO NOT touch any cables during operation as high voltage may cause electric shock.

### Warning:

- To prevent or reduce the risk of electrical shock or fire, do not expose the unit to rain or moisture.
- The housing and lenses must be replaced if they are visibly damaged.

## Installation:

The unit should be mounted via its screw holes on the bracket. Always ensure that the unit is firmly fixed to avoid vibration and slipping while operating. Make sure that the structure to which you are attaching the unit is secure and is able to support a weight of 10 times of the unit's weight. Also always use a safety cable that can hold 12 times of the weight of the unit when installing the fixture.

The equipment must be installed by professionals. It must be installed in a place where is out of the reach of people and no one can pass by or under it.

## 2. Technical Specifications

- 5 DMX Channels: Pan, Tilt, Gobo/Colour, Strobe, Dimmer
- 8 gobos with dichroic colours plus open
- Smooth 0~100% dimming and various strobe effects
- 3 Operation Modes: DMX, Master/Slave and Sound Activation
- Built-in shows in master/slave mode triggered by the music
- Optional easy controller CA-8
- **Power Voltage:** AC 100~240V, 50/60Hz
- **Power Consumption:** 52W
- **Power Cable Daisy Chains:** 11 Fixtures Max. (230V, 50Hz)  
7 Fixtures Max. (120V, 60Hz)
- **LED Source:** 1 x 25W CREE LED
- **Weight:** 3.5kgs
- **Dimensions:** 338 x 168 x 196 mm

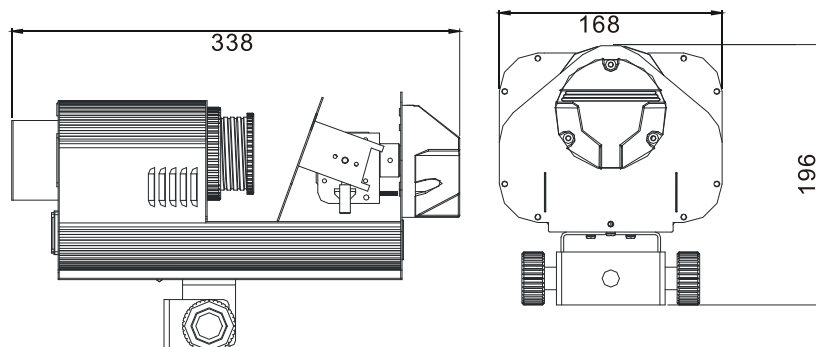

### 3. How To Control The Unit

#### 3.1 Control Panel

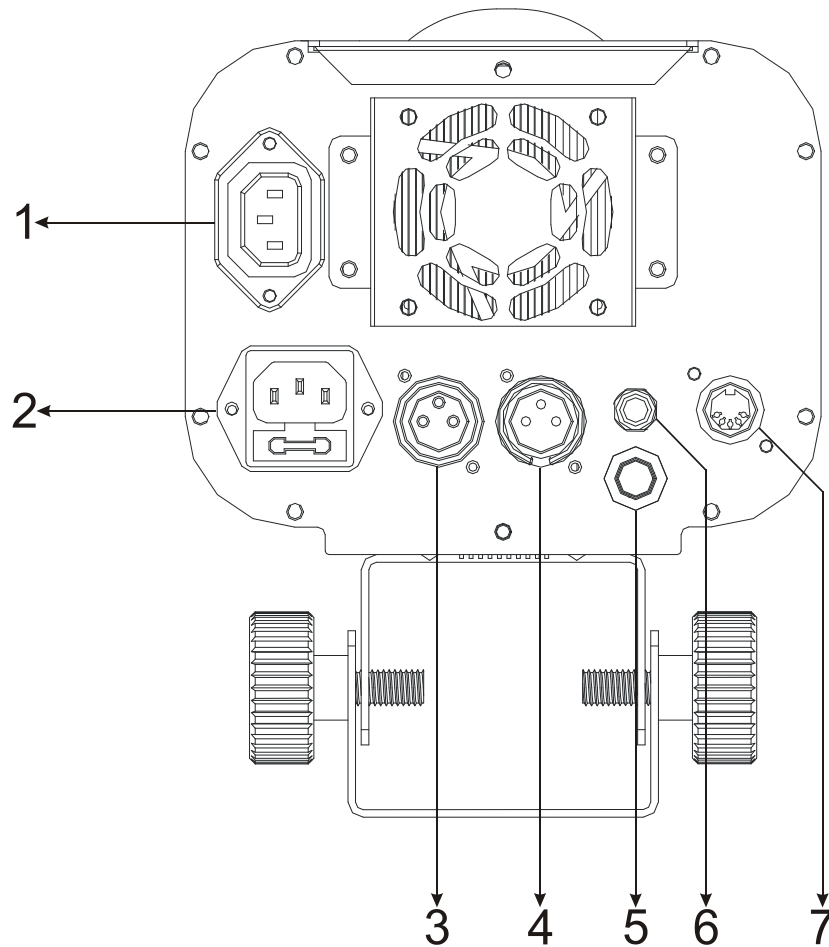

**1. POWER OUT:** Connects to the next unit;

**2. POWER IN:** Connects to supply power;

**3. DMX OUT:** DMX 512 link, use 3-pin XLR cables to link to the next fixture;

**4. DMX IN:** DMX 512 link, use 3-pin XLR cables to link the fixture to a DMX controller;

**5. Microphone:** Used to receive music for sound activation;

**6. Only for remote control:** Used to connect to the CA-8 to control the unit in Stand by,  
Function and Mode;

**7. Only for wireless receiver:** Used to connect to the CA-9 RX to control the unit in Stand by,  
Function and Mode;

### 3.2 Master/Slave Operation

The units can be linked together in a daisy chain in master/slave mode to perform pre-programmed lighting shows triggered by the music.

**In Master/Slave mode refer to the DMX settings below:**

**Master unit:** DMX start address MUST be set to 001. (First DIP switch = ON, all others are OFF)

**Slave units:** DMX start address may have any value but NOT 001 (example: set the first 3 DIP switches to ON)

### 3.3 Easy CA-8 Controller

The easy CA-8 remote control is used only in master/slave modes. By connecting to the remote socket of the first unit you will find that the remote controller on the first unit will control all the other units in Stand by, Function and Mode.

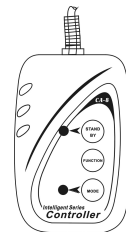

<b>Stand by</b>	Blackout the unit		
<b>Function</b>	1.Synchronous Strobe 2. Sound Strobe	Select show	Select Gobo
<b>Mode</b>	Strobe (LED OFF)	Show(LED ON)	LED blinking

### 3.4 Universal DMX Controller

When using a universal DMX controller to control the chain of units, you have to set a DMX address. Use Dip switches 1 to 9. Dip switch 10 is used to choose the channel mode. Please refer to the following diagram to show how to address your DMX 512 system using the binary code.

#### DMX 512 Address Chart:

Dip-switches	# 1	# 2	# 3	# 4	# 5	# 6	# 7	# 8	# 9	#10
Value	1	2	4	8	16	32	64	128	256	N/A





• **Examples:**

Unit 1 : dip / on: #1 (=1)

Unit 2 : dip / on: #2, #3 (2+4=6)

Unit 3 : dip / on: #1, #2, #4 (1+2+8=11)

Unit 4 : dip / on: #5 (=16)

Channel	Dip switches setting
1	 <p>↓ ON 1 2 3 4 5 6 7 8 9 10</p>
6	 <p>↓ ON 1 2 3 4 5 6 7 8 9 10</p>
11	 <p>↓ ON 1 2 3 4 5 6 7 8 9 10</p>
16	 <p>↓ ON 1 2 3 4 5 6 7 8 9 10</p>

## 4. DMX 512 Configuration

5 Channels Mode:

5 Channels Mode				
Ch1	Ch2	Ch3	Ch4	Ch5
PAN	TILT	STROBE	GOBO	DIMMER
255   0	246-255 Stop  135-245 Right Roll Slow to Fast  121-134 Stop  010-120 Left Roll Slow to Fast  000-009 Stop	248-255 Open 240-247 Random Strobe 232-239 Open 190-231 Fast Open Slow Close 182-189 Open 140-181 Slow Open Fast Close 132-139 Open 016-131 ⚡⚡⚡ ⚡⚡ ⚡ 008-015 Open 000-007 Close	255 Rotation Fast 128 Rotation Slow 121-127 Gobo 8 Shaking 114-120 Gobo 7 Shaking 107-113 Gobo 6 Shaking 100-106 Gobo 5 Shaking 093-099 Gobo 4 Shaking 086-092 Gobo 3 Shaking 079-085 Gobo 2 Shaking 072-078 Gobo 1 Shaking 064-071 White Shaking 057-063 Gobo 8 050-056 Gobo 7 043-049 Gobo 6 036-042 Gobo 5 029-035 Gobo 4 022-028 Gobo 3 015-021 Gobo 2 008-014 Gobo 1 000-007 Open	255 100%   0 0%

Gobo 1 Gobo 2 Gobo 3 Gobo 4 Gobo 5 Gobo 6 Gobo 7 Gobo 8



## 5. DMX 512 Connection

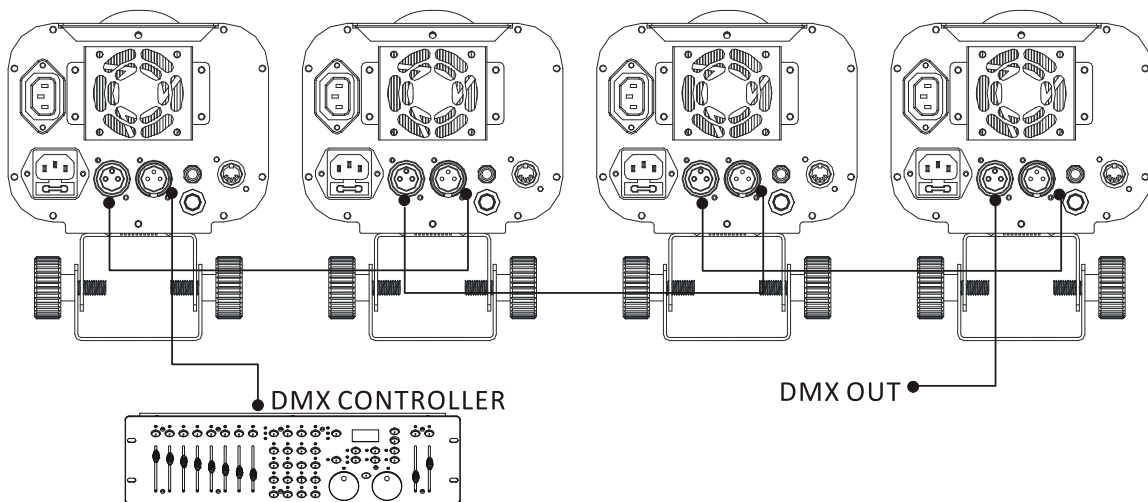



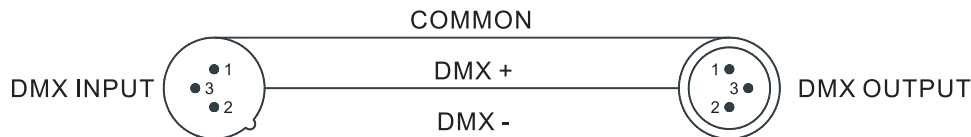

Termination reduces signal errors and to avoid signal transmission problems and interference. It is always advisable to connect a DMX terminal. (Resistance 120 ohm 1/4W) between pin2(DMX-) and pin3(DMX+) of the last fixture.



1. The last units DMX cable has to be terminated with a 120 ohm 1/4W resistor between pin 2(DMX-) and pin 3(DMX+) of a 3-pin XLR-plug and plug it in the DMX-output of the last unit.
  2. Connect the unit together in a `daisy chain` by XLR plug from the output of the unit to the input of the next unit. The cable can not branched or split to a `Y` cable.
  3. The DMX output and input connectors are pass-through type to maintain the DMX circuit, when one of the units' power is disconnected.
  4. Each fixture needs to have an address set to receive the data sent by the controller. The address number is between 0-512 (usually 0 & 1 are equal to 1).
  5. The end of the DMX 512 system should be terminated to reduce signal errors.
- 3 pin XLR: Pin 1: GND, Pin 2: Negative signal (-), Pin 3: Positive signal (+)

## 6. Troubleshooting

Following are a few common problems that may occur during operation. Here are some suggestions for easy troubleshooting:

### A. The fixture does not work, no light output

1. Check the power connection and main fuse.

### B. Not responding to DMX controller

1. DMX LED should be on. If not, check DMX cables to see if linked correctly.
2. If the DMX LED is on and no response to the controller, check the address settings and DMX polarity.
3. Try another DMX controller.

### **C. Fixtures don't respond to the easy CA-8 controller**

1. Check the LED for the response to the master/ slave mode signal.
2. Check if the unit is receiving a DMX signal and disconnect it.

### **D. No response to the sound**

1. Make sure the fixture is not receiving a DMX signal.
2. Check the microphone by tapping it.

## **7. Cleaning and Maintenance**

Cleaning must be carried out periodically to optimize light output. Cleaning frequency depends on the environment in which the fixture operates: moist, smoky or particularly dirty surroundings can cause a greater accumulation of dirt on the fixture.

- Clean with lint-free cloth using normal glass cleaning liquid or mild soapy water.
- Clean the surface at least every 30 days.
- Never use alcohol or solvents.

## **Declaration of Conformity**

We declare that our products (lighting equipments) comply with the following specification and bears CE mark in accordance with the provision of the Electromagnetic Compatibility (EMC) Directive 2004/108/EC.

EN55103-1: 2009 ; EN55103-2: 2009;  
EN61000-3-2: 2006 + A1:2009 + A2:2009; EN61000-3-3: 2008.

**&**

### **Harmonized Standard**

EN 60598-1:2008 + All:2009; EN 60598-2-17:1989 + A2:1991;  
EN 62471:2008; EN 62493: 2010  
Safety of household and similar electrical appliances  
Part 1: General requirements

# **Innovation, Quality, Performance**