

EQUIN X

BALLER@ SPOT

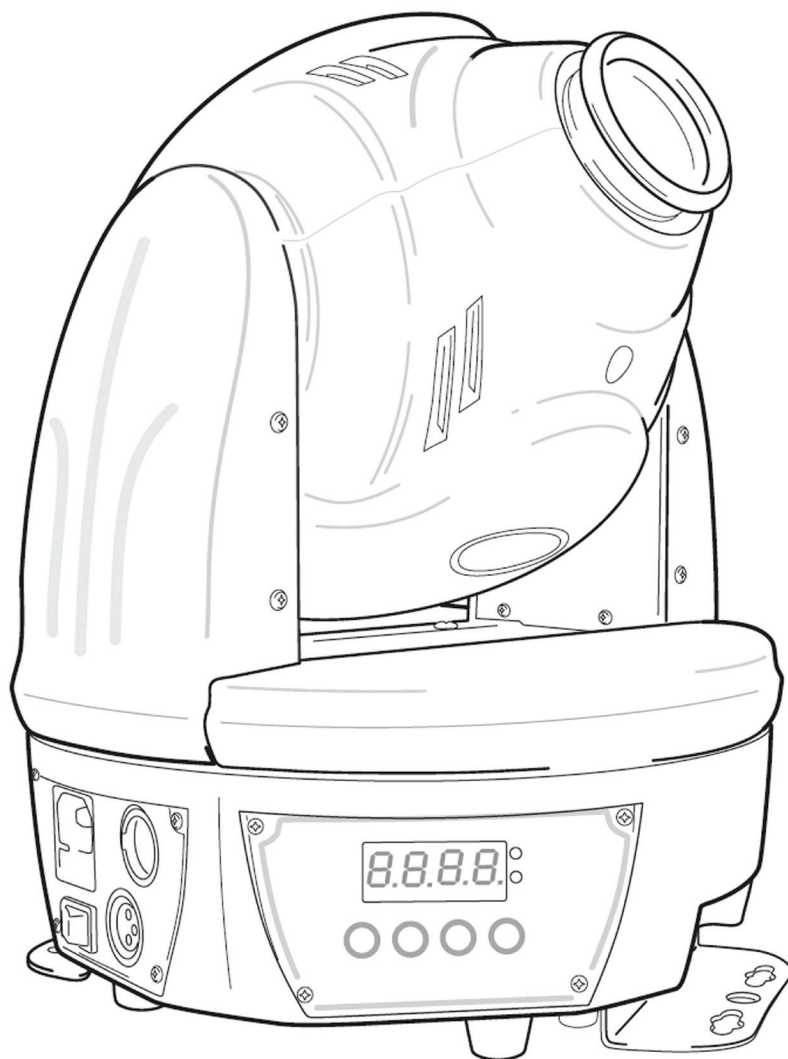

ORDER CODE: EQLED70

USER MANUAL

WARNING

**FOR YOUR OWN SAFETY, PLEASE READ THIS USER MANUAL CAREFULLY
BEFORE YOUR INITIAL START-UP!**

**CAUTION!**

**Keep this equipment away from rain,
moisture and liquids.**

**SAFETY INSTRUCTIONS**

Every person involved with the installation, operation & maintenance of this equipment should:

- Be competent
- Follow the instructions of this manual



**CAUTION! TAKE CARE USING THIS EQUIPMENT!
HIGH VOLTAGE-RISK OF ELECTRIC SHOCK!!**



Before your initial start-up, please make sure that there is no damage caused during transportation. Should there be any, consult your dealer and do not use the equipment.

To maintain the equipment in good working condition and to ensure safe operation, it is necessary for the user to follow the safety instructions and warning notes written in this manual.

Please note that damages caused by user modifications to this equipment are not subject to warranty.

IMPORTANT:

The manufacturer will not accept liability for any resulting damages caused by the non-observance of this manual or any unauthorised modification to the equipment.

- Never let the power-cable come into contact with other cables. Handle the power-cable and all mains voltage connections with particular caution!
- Never remove warning or informative labels from the equipment.
- Do not open the equipment and do not modify the equipment.
- Do not connect this equipment to a dimmer-pack.
- Do not switch the equipment on and off in short intervals, as this will reduce the system's life.
- Only use the equipment indoors.
- Do not expose to flammable sources, liquids or gases.
- Always disconnect the power from the mains when equipment is not in use or before cleaning! Only handle the power-cable by the plug. Never pull out the plug by pulling the power-cable.
- Make sure that the available voltage is between 220v/240v.
- Make sure that the power-cable is never crimped or damaged. Check the equipment and the power-cable periodically.
- If the equipment is dropped or damaged, disconnect the mains power supply immediately. Have a qualified engineer inspect the equipment before operating again.
- If the equipment has been exposed to drastic temperature fluctuation (e.g. after transportation), do not switch it on immediately. The arising condensation might damage the equipment. Leave the equipment switched off until it has reached room temperature.
- If your product fails to function correctly, discontinue use immediately. Pack the unit securely (preferably in the original packing material), and return it to your Prolight dealer for service.
- Only use fuses of same type and rating.
- Repairs, servicing and power connection must only be carried out by a qualified technician. **THIS UNIT CONTAINS NO USER SERVICEABLE PARTS.**
- **WARRANTY;** One year from date of purchase.

OPERATING DETERMINATIONS

If this equipment is operated in any other way, than those described in this manual, the product may suffer damage and the warranty becomes void.

Incorrect operation may lead to danger e.g.: short-circuit, burns, electric shocks, lamp failure etc.

Do not endanger your own safety and the safety of others!
Incorrect installation or use can cause serious damage to people and property.

You should find inside the carton the following items:

1, Equinox Ballero Spot Moving Head 2, Power cable 3, User manual

Technical Specifications:

DMX channels: 10

Operating modes: 1, Sound Activated

2, Auto Run

3, DMX

4, Slave

1 x 30W Mega Bright White LED

Colour wheel: 7 Colours + White

Gobo wheel: 6 Gobo's + Open

4 Push button LED digital display

Beam angle: 11 degrees

Pan: 540°, Tilt: 255°

0-100% dimming + strobe function

Mains IEC Power In socket

3-Pin XLR In/Out sockets for DMX

Power consumption: 100W

Power supply: 240V - 50Hz

Dimensions: 275 x 275 x 305mm

Weight: 7.6Kgs

Overview

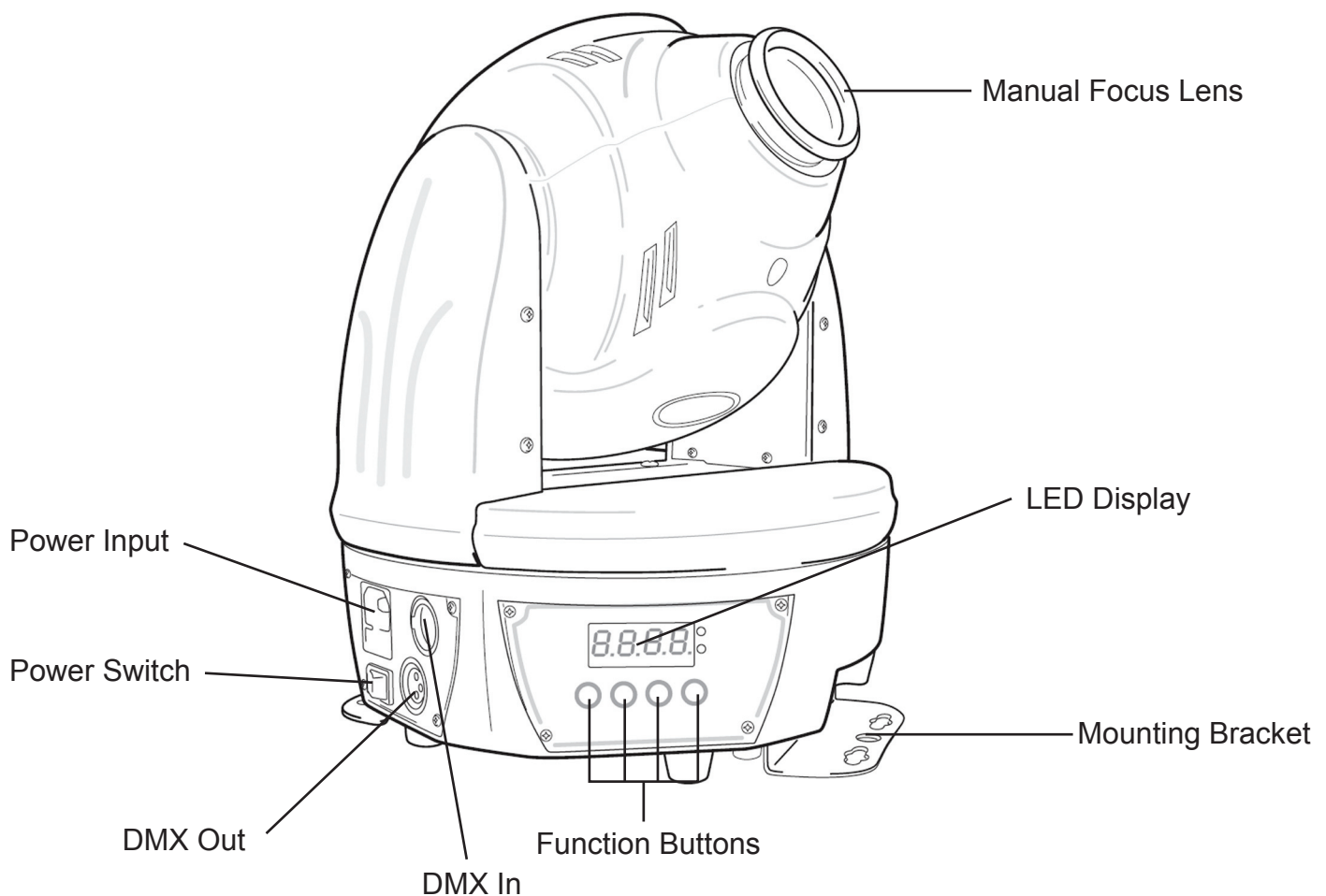

Control Panel Overview:

Button	Function
<ESC>	To access the menu or to return to a previous menu option
<UP>	Scrolls through the menu options in a ascending order
<DOWN>	Scrolls through the menu options in a descending order
<ENTER>	To select and store the current menu or option within a menu.

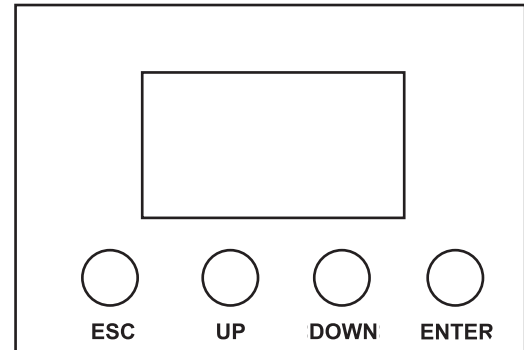

To access the control panel functions, use the four push buttons located under the LED display.

When a function is selected, the LED display will show the first available option for that particular function. To select a menu option, press the “**ENTER**” button.

Press the “**ESC**” button repeatedly until you reach the desired function and use the “**UP**” and “**DOWN**” buttons to navigate through the options. Press the “**ENTER**” button to select the menu function that is currently displayed to enable or disable the menu option. To return to the previous menu or option without changing the value, press the “**ESC**” button.

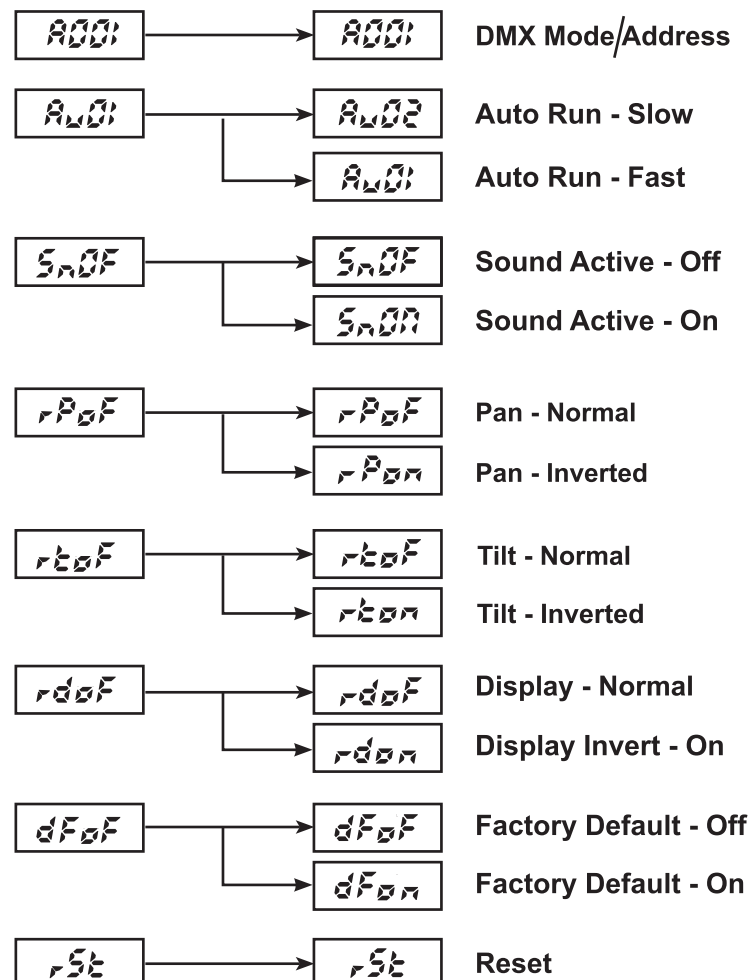
User Menu Configurations:

DMX chart

Channel	Value	Function
1	0-16	White
	17-33	Red
	34-50	Yellow
	51-67	Blue
	68-84	Green
	85-101	Orange
	102-107	Pink
	108-127	Dark Blue
	128-192	Forward Spin (slow - fast)
	193-255	Reverse Spin (slow - fast)
2	0-20	Open
	21-41	Gobo 1
	42-62	Gobo 2
	63-83	Gobo 3
	84-104	Gobo 4
	105-119	Gobo 5
	120-127	Gobo 6
	128-192	Forward Gobo Wheel Rotation (fast - slow)
	193-255	Reverse Gobo Wheel Rotation (slow - fast)
3	0-126	Forward Gobo Rotation (fast - slow)
	127-255	Reverse Gobo Rotation (slow - fast)
4	0-10	Blackout
	11-115	Master Dimmer (0 - 100%)
	116-243	Strobe Speed (slow to fast)
	244-255	Full On
5	0-255	Pan Movement
6	0-255	Tilt Movement
7	0-255	Pan/Tilt Movement Speed (fast - slow)
8	0-255	Pan 16 Bit Fine
9	0-255	Tilt 16 Bit Fine
10	0-149	No Function
	150-200	Reset
	201-255	No Function

DMX Control Mode

Operating in a DMX control mode environment gives the user the greatest flexibility when it comes to customising or creating a show. In this mode you will be able to control each individual trait of the fixture and each fixture independently.

Setting the DMX address

The DMX mode enables the use of a universal DMX controller. Each fixture requires a “start address” from 1- 511. A fixture requiring one or more channels for control begins to read the data on the channel indicated by the start address. For example, a fixture that occupies or uses 7 channels of DMX and was addressed to start on DMX channel 100, would read data from channels: 100,101,102,103,104,105 and 106. Choose a start address so that the channels used do not overlap. E.g. the next unit in the chain starts at 107.

DMX-512:

- DMX (Digital Multiplex) is a universal protocol used as a form of communication between intelligent fixtures and controllers. A DMX controller sends DMX data instructions from the controller to the fixture. DMX data is sent as serial data that travels from fixture to fixture via the DATA “IN” and DATA “OUT” XLR terminals located on all DMX fixtures (most controllers only have a data “out” terminal).

DMX Linking:

- DMX is a language allowing all makes and models of different manufactures to be linked together and operate from a single controller, as long as all fixtures and the controller are DMX compliant. To ensure proper DMX data transmission, when using several DMX fixtures try to use the shortest cable path possible. The order in which fixtures are connected in a DMX line does not influence the DMX addressing. For example; a fixture assigned to a DMX address of 1 may be placed anywhere in a DMX line, at the beginning, at the end, or anywhere in the middle. When a fixture is assigned a DMX address of 1, the DMX controller knows to send DATA assigned to address 1 to that unit, no matter where it is located in the DMX chain.

DATA Cable (DMX cable) requirements (for DMX operation):

- The Equinox Ballero Spot can be controlled via DMX-512 protocol. The DMX address is set on the back of the unit. Your unit and your DMX controller require a standard 3-pin XLR connector for data input/output (figure 1).

Figure 1



Further DMX cables can be purchased from all good sound and lighting suppliers or Proflight dealers.

Please quote:

CABL10 – 2M

CABL11 – 5M

CABL12 – 10M

Also remember that DMX cable must be daisy chained and cannot be split.

Notice:

- Be sure to follow figures 2 & 3 when making your own cables. Do not connect the cable's shield conductor to the ground lug or allow the shield conductor to come in contact with the XLR's outer casing. Grounding the shield could cause a short circuit and erratic behaviour.

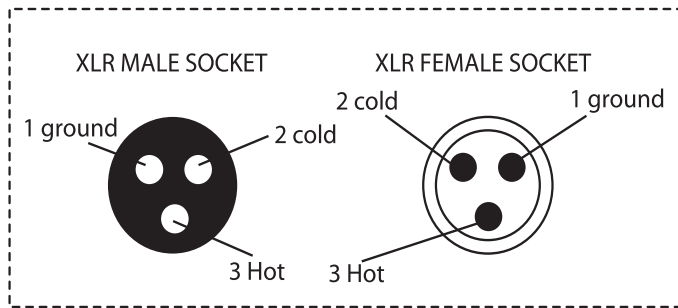
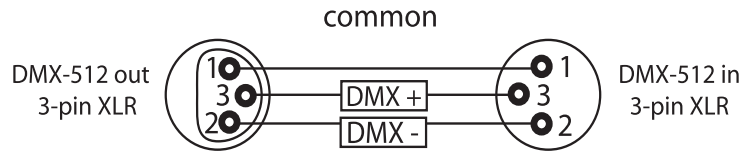

FIGURE 3

XLR Pin Configuration
Pin 1 = Ground
Pin 2 = Negative
Pin 3 = Postive

FIGURE 2

Special Note: Line termination:

- When longer runs of cable are used, you may need to use a terminator on the last unit to avoid erratic behaviour.

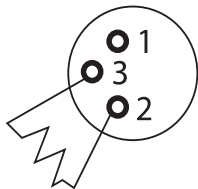

Termination reduces signal transmission problems and interference. it is always advisable to connect a DMX terminal, (resistance 120 Ohm 1/4 W) between pin 2 (DMX-) and pin 3 (DMX+) of the last fixture.

Using a cable terminator (part number CABL90) will decrease the possibilities of erratic behaviour.

5-Pin XLR DMX Connectors:

- Some manufactures use 5-pin XLR connectors for data transmission in place of 3-pin. 5-Pin XLR fixtures may be implemented in a 3-pin XLR DMX line. When inserting standard 5-pin XLR connectors in to a 3-pin line a cable adaptor must be used. The Chart below details the correct cable conversion.

