

EQUINOX

Butterfly Quad MKII

User Manual



Order code: EQLED440

WARNING

FOR YOUR OWN SAFETY, PLEASE READ THIS USER MANUAL CAREFULLY BEFORE YOUR INITIAL START-UP!

- Before your initial start-up, please make sure that there is no damage caused during transportation.
- Should there be any damage, consult your dealer and do not use the equipment.
- To maintain the equipment in good working condition and to ensure safe operation, it is necessary for the user to follow the safety instructions and warning notes written in this manual.
- Please note that damages caused by user modifications to this equipment are not subject to warranty.



IMPORTANT:

The manufacturer will not accept liability for any resulting damages caused by the non-observance of this manual or any unauthorised modification to the equipment.

- Never let the power cable come into contact with other cables. Handle the power cable and all mains voltage connections with particular caution!
- Never remove warning or informative labels from the unit.
- Do not open the equipment and do not modify the unit.
- Do not connect this equipment to a dimmer pack.
- Do not switch the equipment on and off in short intervals, as this will reduce the system's life.
- Only use the equipment indoors.
- Do not expose to flammable sources, liquids or gases.
- Always disconnect the power from the mains when equipment is not in use or before cleaning! Only handle the power-cable by the plug. Never pull out the plug by pulling the power-cable.
- Make sure that the available mains supply voltage is between 100~240V AC, 50/60Hz.
- Make sure that the power cable is never crimped or damaged. Check the equipment and the power cable periodically.
- If the equipment is dropped or damaged, disconnect the mains power supply immediately and have a qualified engineer inspect the equipment before operating again.
- If the equipment has been exposed to drastic temperature fluctuation (e.g. after transportation), do not connect power or switch it on immediately. The arising condensation might damage the equipment. Leave the equipment switched off until it has reached room temperature.
- If your product fails to function correctly, stop use immediately. Pack the unit securely (preferably in the original packing material), and return it to your Pro Light dealer for service.
- Only use fuses of same type and rating.
- Repairs, servicing and power connection must only be carried out by a qualified technician. THIS UNIT CONTAINS NO USER SERVICEABLE PARTS.
- This lighting fixture is for professional use only - it is not designed for or suitable for household use. The product must be installed by a qualified technician in accordance with local territory regulations. The safety of the installation is the responsibility of the installer. The fixture presents risks of severe injury or death due to fire hazards, electric shock and falls.
- Warning! Risk Group 2 LED product according to EN 62471. Do not view the light output with optical instruments or any device that may concentrate the beam.
- WARRANTY: One year from date of purchase.

OPERATING DETERMINATIONS

If this equipment is operated in any other way, than those described in this manual, the product may suffer damage and the warranty becomes void. Incorrect operation may lead to danger e.g: short-circuit, burns and electric shocks etc.

Do not endanger your own safety and the safety of others!

Incorrect installation or use can cause serious damage to people and/or property.

Please note: These fixtures are intended for stage lighting and entertainment applications only, and are not intended for extended periods of use, including but not limited to house-light, industrial or architectural applications and should only be operated with short duty cycles.

Butterfly Quad MKII

The Butterfly Quad is a dynamic multi-beam effect featuring two sweeping LED bars, each loaded with four individually controllable narrow beams. Dispensing eight intense and sharp long-throw beams the Butterfly cuts through the air with ease. The four button menu system allows control of master/slave functions, and the fixture can be also be operated in auto, sound active and DMX modes.



- 8 x 10W quad-colour LEDs (RGBW)
- Beam angle: 3°
- Pixel mapping capabilities
- Refresh rate: 4kHz
- DMX channels: 1/6/ 12 or 36 selectable
- Auto, sound active and master/slave modes
- 0-100% dimming
- Variable strobe
- Tilt: 160°
- Supplied with hanging bracket
- 4 button menu with LED display
- IEC power input/output
- 3-Pin XLR input/output

Specifications	
Power consumption	100W
Power supply	100~240V, 50/60Hz
Fuse	F3A 250V
Dimensions	148 x 402 x 235mm
Weight	4.1kg
Order code	EQLED440

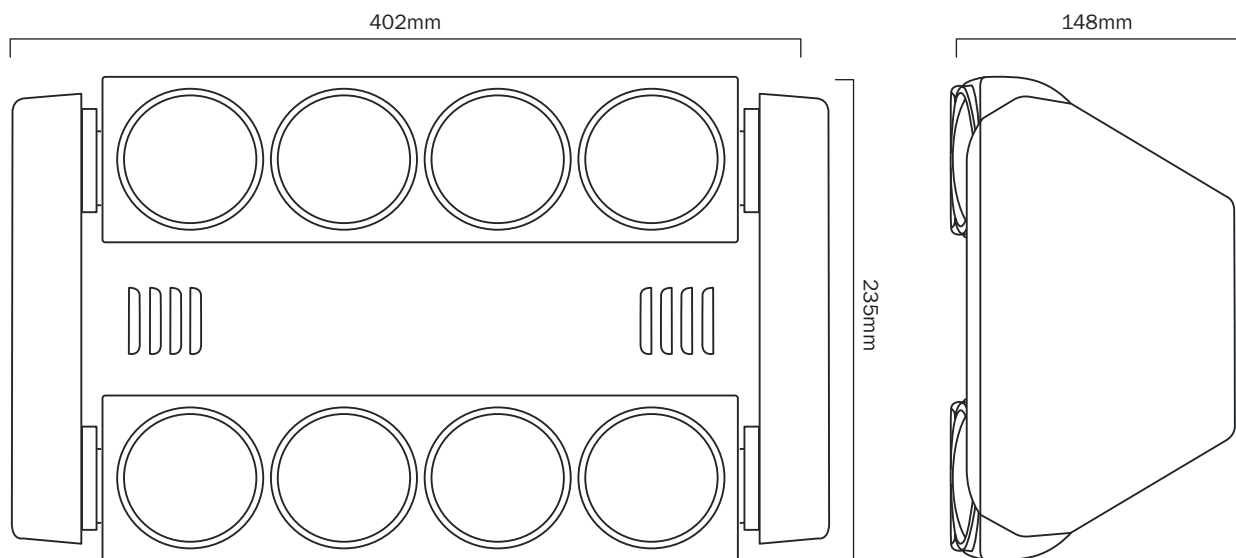

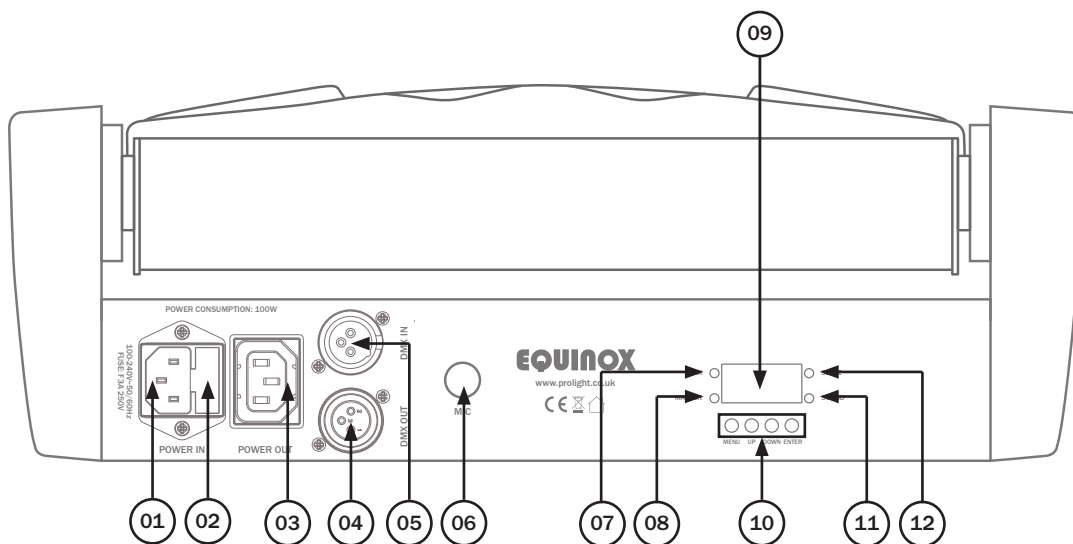

01 - IEC power input
 02 - Fuse F3A 250V
 03 - IEC power output
 04 - 3-Pin XLR DMX output

05 - 3-Pin XLR DMX input
 06 - Microphone
 07 - DMX LED
 08 - Master LED

09 - LED display
 10 - Function buttons
 11 - Sound LED
 12 - Slave LED

In the box: **1 x fixture**
& 1 x power cable

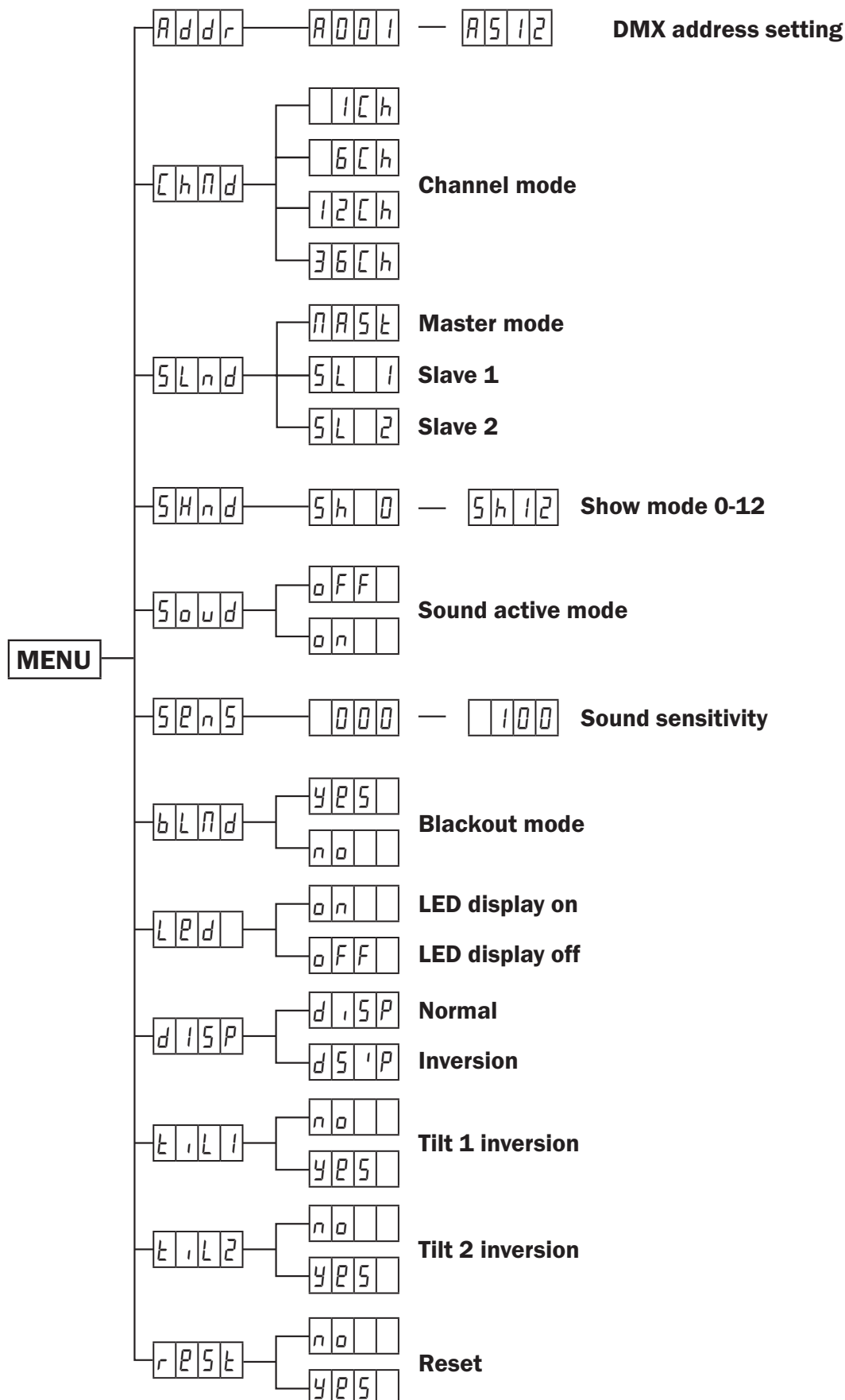

DMX mode:

Operating in a DMX control mode environment gives the user the greatest flexibility when it comes to customising or creating a show. In this mode you will be able to control each individual trait of the fixture and each fixture independently.

To access the DMX address mode, press the “**MENU**” button on the front of the unit to show *Addr* on the LED display. Now press the “**ENTER**” button and use the “**UP**” and “**DOWN**” buttons to set the required DMX address. Press the “**ENTER**” button to confirm the setting.

To exit out of any of the above options, press the “**MENU**” button.

To access the DMX channel mode, press the “**MENU**” button on the front of the unit to show *[Chn]* on the LED display. Now press the “**ENTER**” button and use the “**UP**” and “**DOWN**” buttons to choose one of the 1/6/12 or 36 DMX channel modes. Press the “**ENTER**” button to confirm the setting.

1 channel mode:

Channel	Value	Function
CH1	000-015	No function
	016-128	Auto mode
	129-255	Sound mode

Please note: The unit must be in slave mode to work on DMX

6 channel mode:

Channel	Value	Function
CH1	000-255	Tilt 1 Movement (60°-150°)
CH2	000-255	Tilt 2 Movement (60°-150°)
CH3	000-255	Master dimmer (0-100%)
CH4	000-009	No function
	010-249	Strobe (slow-fast)
	250-255	No function
CH5	000-000	No function
	001-007	Program 1
	008-011	Program 2
	012-016	Program 3
	017-021	Program 4
	022-026	Program 5
	027-031	Program 6
	032-036	Program 7
	037-041	Program 8
	042-046	Program 9
	047-051	Program 10
	052-056	Program 11
	057-061	Program 12
	062-066	Program 13
	067-071	Program 14
	072-076	Program 15
	077-081	Program 16
	082-086	Program 17
	087-091	Program 18
	092-096	Program 19
	097-101	Program 20
	102-106	Program 21
	107-111	Program 22
	112-116	Program 23
	117-121	Program 24
	122-126	Program 25
	127-131	Program 26
	132-136	Program 27
	137-140	Program 28
	141-143	Sound 1
	144-147	Sound 2
	148-151	Sound 3
152-155	Sound 4	
156-159	Sound 5	
160-163	Sound 6	

Channel	Value	Function
CH5	164-167	Sound 7
	168-171	Sound 8
	172-175	Sound 9
	176-179	Sound 10
	180-183	Sound 11
	184-187	Sound 12
	188-191	Sound 13
	192-195	Sound 14
	196-199	Sound 15
	200-203	Sound 16
	204-207	Sound 17
	208-211	Sound 18
	212-215	Sound 19
	216-219	Sound 20
	220-223	Sound 21
	224-227	Sound 22
	228-231	Sound 23
	232-235	Sound 24
236-239	Sound 25	
240-255	Sound 26	
CH6	000-255	Program speed (slow-fast)

12 channel mode:

Channel	Value	Function
CH1	000-255	Tilt 1 Movement (60°-150°)
CH2	000-255	Tilt 2 Movement (60°-150°)
CH3	000-255	Master dimmer (0-100%)
CH4	000-009	No function
	010-249	Strobe (slow-fast)
	250-255	No function
CH5	000-015	No function
	016-031	LED 1 Red
	032-047	LED 1 Green
	048-063	LED 1 Blue
	064-079	LED 1 White
	080-095	LED 1 Yellow
	096-111	LED 1 Magenta
	112-127	LED 1 Light Red
	128-143	LED 1 Cyan
	144-159	LED 1 Light Green
	160-175	LED 1 Light Blue
	176-191	LED 1 Cool White
	192-207	LED 1 Warm White
	208-223	LED 1 Light Pink
	224-239	LED 1 Sky Blue
	240-255	LED 1 White
CH6	000-015	No function
	016-031	LED 2 Red
	032-047	LED 2 Green
	048-063	LED 2 Blue
	064-079	LED 2 White
	080-095	LED 2 Yellow
	096-111	LED 2 Magenta
	112-127	LED 2 Light Red
	128-143	LED 2 Cyan
	144-159	LED 2 Light Green
	160-175	LED 2 Light Blue
	176-191	LED 2 Cool White
	192-207	LED 2 Warm White
	208-223	LED 2 Light Pink
	224-239	LED 2 Sky Blue
	240-255	LED 2 White

Channel	Value	Function
CH7	000-015	No function
	016-031	LED 3 Red
	032-047	LED 3 Green
	048-063	LED 3 Blue
	064-079	LED 3 White
	080-095	LED 3 Yellow
	096-111	LED 3 Magenta
	112-127	LED 3 Light Red
	128-143	LED 3 Cyan
	144-159	LED 3 Light Green
	160-175	LED 3 Light Blue
	176-191	LED 3 Cool White
	192-207	LED 3 Warm White
	208-223	LED 3 Light Pink
	224-239	LED 3 Sky Blue
	240-255	LED 3 White
CH8	000-015	No function
	016-031	LED 4 Red
	032-047	LED 4 Green
	048-063	LED 4 Blue
	064-079	LED 4 White
	080-095	LED 4 Yellow
	096-111	LED 4 Magenta
	112-127	LED 4 Light Red
	128-143	LED 4 Cyan
	144-159	LED 4 Light Green
	160-175	LED 4 Light Blue
	176-191	LED 4 Cool White
	192-207	LED 4 Warm White
	208-223	LED 4 Light Pink
	224-239	LED 4 Sky Blue
	240-255	LED 4 White

12 channel mode (cont.):

Channel	Value	Function
CH9	000-015	No function
	016-031	LED 5 Red
	032-047	LED 5 Green
	048-063	LED 5 Blue
	064-079	LED 5 White
	080-095	LED 5 Yellow
	096-111	LED 5 Magenta
	112-127	LED 5 Light Red
	128-143	LED 5 Cyan
	144-159	LED 5 Light Green
	160-175	LED 5 Light Blue
	176-191	LED 5 Cool White
	192-207	LED 5 Warm White
	208-223	LED 5 Light Pink
	224-239	LED 5 Sky Blue
	240-255	LED 5 White
CH10	000-015	No function
	016-031	LED 6 Red
	032-047	LED 6 Green
	048-063	LED 6 Blue
	064-079	LED 6 White
	080-095	LED 6 Yellow
	096-111	LED 6 Magenta
	112-127	LED 6 Light Red
	128-143	LED 6 Cyan
	144-159	LED 6 Light Green
	160-175	LED 6 Light Blue
	176-191	LED 6 Cool White
	192-207	LED 6 Warm White
	208-223	LED 6 Light Pink
	224-239	LED 6 Sky Blue
	240-255	LED 6 White

Channel	Value	Function
CH11	000-015	No function
	016-031	LED 7 Red
	032-047	LED 7 Green
	048-063	LED 7 Blue
	064-079	LED 7 White
	080-095	LED 7 Yellow
	096-111	LED 7 Magenta
	112-127	LED 7 Light Red
	128-143	LED 7 Cyan
	144-159	LED 7 Light Green
	160-175	LED 7 Light Blue
	176-191	LED 7 Cool White
	192-207	LED 7 Warm White
	208-223	LED 7 Light Pink
	224-239	LED 7 Sky Blue
	240-255	LED 7 White
CH12	000-015	No function
	016-031	LED 8 Red
	032-047	LED 8 Green
	048-063	LED 8 Blue
	064-079	LED 8 White
	080-095	LED 8 Yellow
	096-111	LED 8 Magenta
	112-127	LED 8 Light Red
	128-143	LED 8 Cyan
	144-159	LED 8 Light Green
	160-175	LED 8 Light Blue
	176-191	LED 8 Cool White
	192-207	LED 8 Warm White
	208-223	LED 8 Light Pink
	224-239	LED 8 Sky Blue
	240-255	LED 8 White

36 channel mode:

Channel	Value	Function
CH1	000-255	Tilt 1 Movement (60°-150°)
CH2	000-255	Tilt 2 Movement (60°-150°)
CH3	000-255	Master dimmer (0-100%)
CH4	000-009	No function
	010-249	Strobe (slow-fast)
	250-255	No function
CH5	000-255	LED 1 Red (0-100% dimming)
CH6	000-255	LED 1 Green (0-100% dimming)
CH7	000-255	LED 1 Blue (0-100% dimming)
CH8	000-255	LED 1 White (0-100% dimming)
CH9	000-255	LED 2 Red (0-100% dimming)
CH10	000-255	LED 2 Green (0-100% dimming)
CH11	000-255	LED 2 Blue (0-100% dimming)
CH12	000-255	LED 2 White (0-100% dimming)
CH13	000-255	LED 3 Red (0-100% dimming)
CH14	000-255	LED 3 Green (0-100% dimming)
CH15	000-255	LED 3 Blue (0-100% dimming)
CH16	000-255	LED 3 White (0-100% dimming)
CH17	000-255	LED 4 Red (0-100% dimming)
CH18	000-255	LED 4 Green (0-100% dimming)
CH19	000-255	LED 4 Blue (0-100% dimming)
CH20	000-255	LED 4 White (0-100% dimming)
CH21	000-255	LED 5 Red (0-100% dimming)
CH22	000-255	LED 5 Green (0-100% dimming)
CH23	000-255	LED 5 Blue (0-100% dimming)
CH24	000-255	LED 5 White (0-100% dimming)
CH25	000-255	LED 6 Red (0-100% dimming)
CH26	000-255	LED 6 Green (0-100% dimming)
CH27	000-255	LED 6 Blue (0-100% dimming)
CH28	000-255	LED 6 White (0-100% dimming)
CH29	000-255	LED 7 Red (0-100% dimming)
CH30	000-255	LED 7 Green (0-100% dimming)
CH31	000-255	LED 7 Blue (0-100% dimming)
CH32	000-255	LED 7 White (0-100% dimming)
CH33	000-255	LED 8 Red (0-100% dimming)
CH34	000-255	LED 8 Green (0-100% dimming)
CH35	000-255	LED 8 Blue (0-100% dimming)
CH36	000-255	LED 8 White (0-100% dimming)

To exit out of any of the above options, press the “MENU” button.

Master/slave mode:

To set the master unit, press the “MENU” button on the front of the master unit to show *SLnd* on the LED display. Now press the “ENTER” button and use the “UP” and “DOWN” buttons to choose *PRST*. Press the “ENTER” button to confirm the setting. Then select your desired program (sound active, DMX or one of the built-in programs).

To set the other units in slave mode, press the “MENU” button on the front of the unit to show *SLnd* on the LED display. Now press the “ENTER” button and use the “UP” and “DOWN” buttons to choose either *SL 1* (Slave 1) or *SL 2* (Slave 2). Press the “ENTER” button to confirm the setting. The unit will now run in sequence with the master unit.

To exit out of any of the above options, press the “MENU” button.

Please ensure that all slave units are set to the same DMX channel mode as the master unit.

Show mode (built-in programs):

To access the show modes, press the “MENU” button on the front of the unit to show *SHnd* on the LED display. Now press the “ENTER” button and use the “UP” and “DOWN” buttons to choose the show you require from *SH 0* ~ *SH 12*. Press the “ENTER” button to confirm the setting.

To exit out of any of the above options, press the “MENU” button.

Sound active mode:

To access the sound active mode, press the “MENU” button on the front of the unit to show *Sound* on the LED display. Now press the “ENTER” button and use the “UP” and “DOWN” buttons to set the sound mode on or off. Press the “ENTER” button to confirm the setting.

To adjust the sound sensitivity, press the “MENU” button on the front of the unit to show *SENS* on the LED display. Now press the “ENTER” button and use the “UP” and “DOWN” buttons to set the sound sensitivity *0* ~ *100*. Press the “ENTER” button to confirm the setting.

Value: 0 - 100 (0 = low sensitivity, 100 = high sensitivity)

To exit out of any of the above options, press the “MENU” button.

Blackout mode:

To access the blackout mode, press the “MENU” button on the front of the unit to show *BLnd* on the LED display. Now press the “ENTER” button and use the “UP” and “DOWN” buttons to set the blackout mode on or off. Press the “ENTER” button to confirm the setting.

To exit out of any of the above options, press the “MENU” button.

LED Display:

To access the LED display setting, press the “MENU” button on the front of the unit to show *LED* on the LED display. Now press the “ENTER” button and use the “UP” and “DOWN” buttons to set the LED display *ON* or *OFF*. Press the “ENTER” button to confirm the setting.

To exit out of any of the above options, press the “MENU” button.

LED Display inversion:

To invert the LED display, press the “MENU” button on the front of the unit to show *d 1SP* on the LED display. Now press the “ENTER” button and use the “UP” and “DOWN” buttons to set the LED display to *d 1SP* (normal) or *dS 'P* (inverted.) Press the “ENTER” button to confirm the setting.

To exit out of any of the above options, press the “MENU” button.

Tilt inversion:

To invert the tilt, press the “MENU” button on the front of the unit to show *t 1L 1* or *t 1L 2* on the LED display. Now press the “ENTER” button and use the “UP” and “DOWN” buttons to set the tilt between *4PS* or *no*. Press the “ENTER” button to confirm the setting.

To exit out of any of the above options, press the “MENU” button.

Factory reset:

To restore the fixture to factory settings, press the “MENU” button on the front of the unit to show *r ESt* on the LED display. Now press the “ENTER” button and use the “UP” and “DOWN” to choose between *4PS* or *no*. Press the “ENTER” button to confirm the setting.

To exit out of any of the above options, press the “MENU” button.

Setting the DMX address:

The DMX mode enables the use of a universal DMX controller. Each fixture requires a “start address” from 1- 512. A fixture requiring one or more channels for control begins to read the data on the channel indicated by the start address. For example, a fixture that occupies or uses 7 channels of DMX and was addressed to start on DMX channel 100, would read data from channels: 100, 101, 102, 103, 104, 105 and 106. Choose a start address so that the channels used do not overlap. E.g. the next unit in the chain starts at 107.

DMX 512:

DMX (Digital Multiplex) is a universal protocol used as a form of communication between intelligent fixtures and controllers. A DMX controller sends DMX data instructions from the controller to the fixture. DMX data is sent as serial data that travels from fixture to fixture via the DATA “IN” and DATA “OUT” XLR terminals located on all DMX fixtures (most controllers only have a data “out” terminal).

DMX linking:

DMX is a language allowing all makes and models of different manufactures to be linked together and operate from a single controller, as long as all fixtures and the controller are DMX compliant. To ensure proper DMX data transmission, when using several DMX fixtures try to use the shortest cable path possible. The order in which fixtures are connected in a DMX line does not influence the DMX addressing. For example; a fixture assigned to a DMX address of 1 may be placed anywhere in a DMX line, at the beginning, at the end, or anywhere in the middle. When a fixture is assigned a DMX address of 1, the DMX controller knows to send DATA assigned to address 1 to that unit, no matter where it is located in the DMX chain.

DATA cable (DMX cable) requirements (for DMX operation):

This fixture can be controlled via DMX-512 protocol. The DMX address is set on the back of the unit. Your unit requires either a standard 3-pin connector for data input/output, see image below.



Further DMX cables can be purchased from all good sound and lighting suppliers or Prolight Concepts dealers.
Please quote: 3-Pin: **CABL10 – 2m** **CABL11 – 5m** **CABL12 – 10m**

Also remember that DMX cable must be daisy chained and cannot be split.

Notice:

Be sure to follow the diagrams below when making your own cables. Do not connect the cables shield conductor to the ground lug or allow the shield conductor to come in contact with the XLRs outer casing. Grounding the shield could cause a short circuit and erratic behaviour.

Pin Configuration	
3-Pin	5-Pin
	Pin 1 - Ground
	Pin 2 - Negative
	Pin 3 - Positive
-	Pin 4 - N/C
-	Pin 5 - N/C

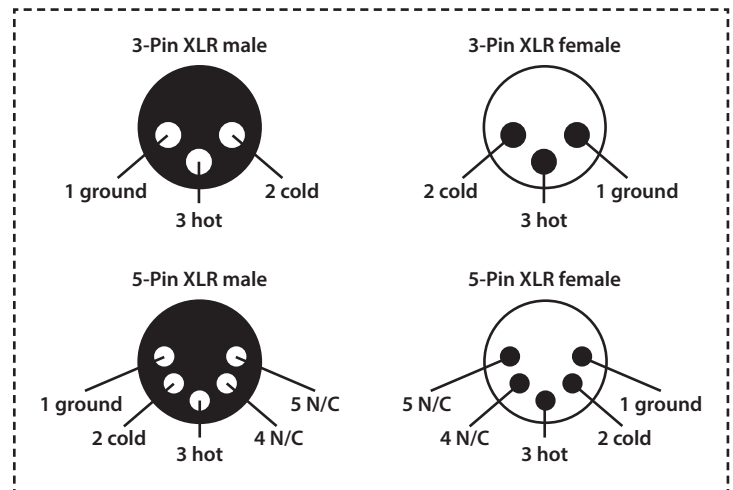
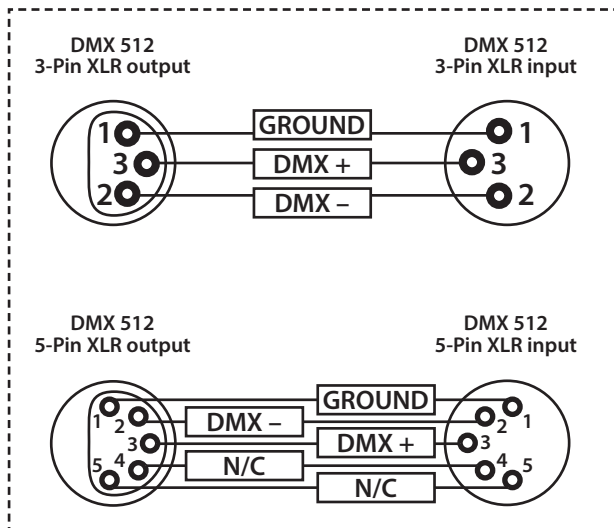

Line termination:

When longer runs of cable are used, you may need to use a terminator on the last unit to avoid erratic behaviour.

Using a cable terminator will decrease the possibilities of erratic behaviour.

(3-pin - Order ref: CABL90,
5-pin - Order ref: CABL89)

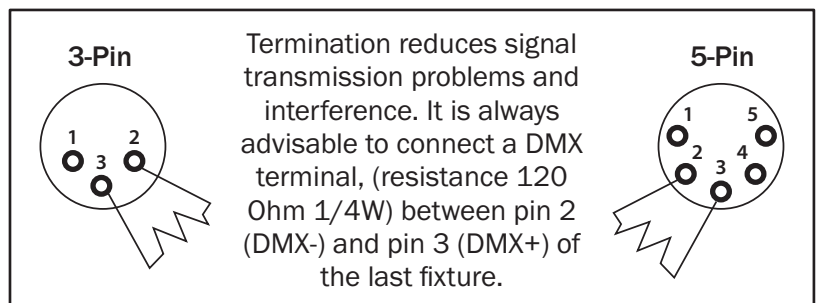

Termination reduces signal transmission problems and interference. It is always advisable to connect a DMX terminal, (resistance 120 Ohm 1/4W) between pin 2 (DMX-) and pin 3 (DMX+) of the last fixture.

5-pin XLR DMX connectors:

Some manufactures use 5-pin XLR connectors for data transmission in place of 3-pin. 5-pin XLR fixtures may be implemented in a 3-pin XLR DMX line. When inserting standard 5-pin XLR connectors in to a 3-pin line a cable adaptor must be used. The diagram below details the correct cable conversion.

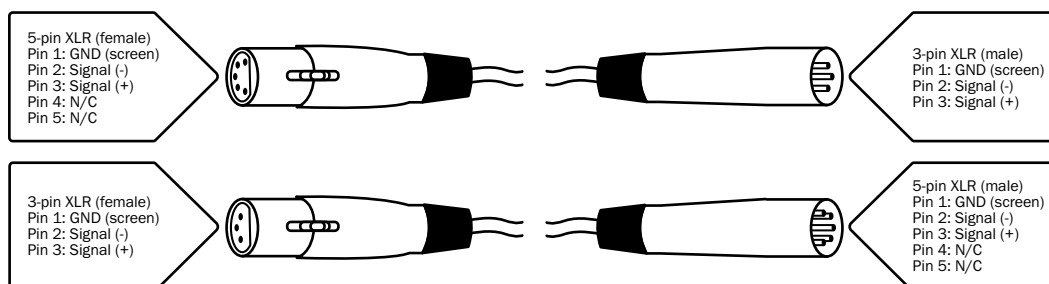



Correct Disposal of this Product (Waste Electrical & Electronic Equipment)

**(Applicable in the European Union and other European countries
with separate collection systems)**

This marking shown on the product or its literature, indicates that it should not be disposed of with other household wastes at the end of its working life. To prevent possible harm to the environment or human health from uncontrolled waste disposal, please separate this from other types of wastes and recycle it responsibly to promote the sustainable reuse of material resources.

Household users should contact either the retailer where they purchased this product, or their local government office, for details of where and how they can take this item for environmentally safe recycling.

Business users should contact their supplier and check the terms and conditions of the purchase contract. This product should not be mixed with other commercial wastes for disposal.

