

# Color Fusion

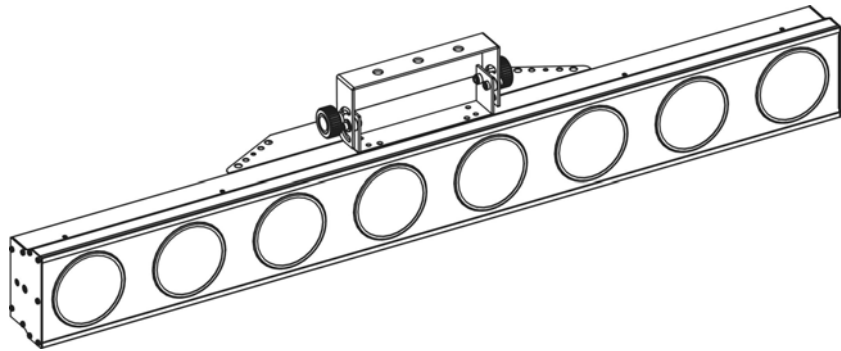

## User Manual

Please read the instructions carefully before use

### TABLE OF CONTENTS

1. Safety Instructions
2. Technical Specifications
3. Installation
  - 3.1 Fuse Replacement
4. How to Set the Unit
  - 4.1. Control Panel
  - 4.2. Main Function
5. DMX512 Address setting
6. How to control the fixture
7. DMX512 Connection
8. Fixture Cleaning

## 1. Safety Introductions



**WARNING**

Please read the instructions carefully which includes important information about the installation, operation and maintenance.

- Please keep the User Manual for future consultation. Please be sure receive this instruction booklet.
- Unpack and check carefully there is no transportation damage before using the fixture.
- Please ensure the voltage and frequency of power supply match the power requirements of the fixture.
- It's important to ground the yellow/green conductor to earth in order to avoid electric shock.
- Disconnect main power before servicing and maintenance.
- Use safety chain when fixes this fixture. Don't handle the fixture by taking its head only, but always by taking its base.
- Maximum ambient temperature is  $T_a : 40^{\circ}\text{C}$ .
- In the event of serious operating problem, stop using the fixture immediately. Never try to repair the fixture by yourself. Repairs carried out by unskilled people can lead to damage or malfunction. Please contact the nearest authorized technical assistance center. Always use the same type spare parts.
- Do not connect the device to any dimmer pack.
- Do not touch any wire during operation and there might be a hazard of electric shock.
- To prevent or reduce the risk of electrical shock or fire, do not expose the fixture to rain or moisture.
- The housing must be replaced if they are visibly damaged.
- Do not look directly at the LED light beam while it may cause some eye damaged.
- There are no user serviceable parts inside the fixture. Do not open the housing or attempt any repairs by yourself. In the unlikely event your fixture may require service, please contact your nearest dealer.

## 2. Technical Specifications

### • Power supply

AC 120V 60Hz  
AC 230/240/250V 50/60Hz

- Power consumption : 105 Watts

### • LED

Red 200pcs, Green 200pcs, Blue 208pcs

### • Channels

6, 9, 15, 27, 24 channel mode

- Dimension : 1192 x 135 x 139.6 mm

- Weight : 10 kg

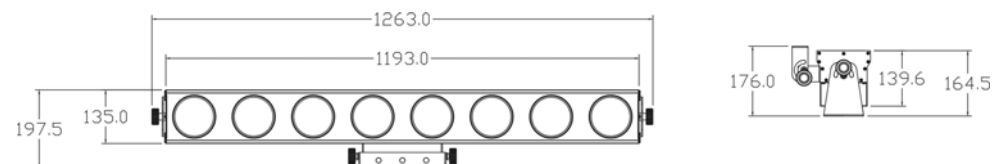

### • Luminous intensity:

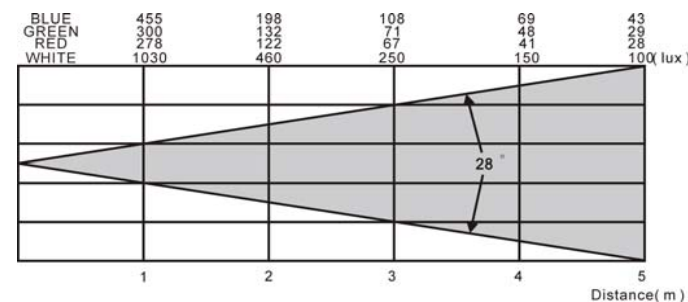

### 3. Installation

- The fixture is able to hanging on the truss to increase the pleased ambience.
- Please check the voltage before plugging the power.
- Do not use an electrical dimmer system, it will damage the inside electronics.
- The unit should be mounted via screw holes on the bracket.
- Always ensure the unit is firmly fixed to avoiding vibration and slipping while operating.
- Always ensure the structure is strong enough to support a weight of 10kgs for each unit.

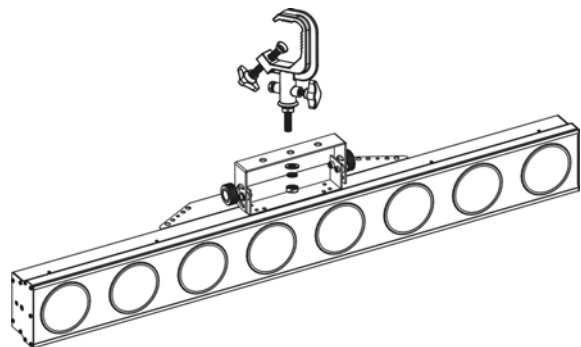

#### 3.1 Fuse Replacement

The fuse of Color Fusion may be replaced as below.

First, disconnect AC mains power before replacing and replace with the same fuse.

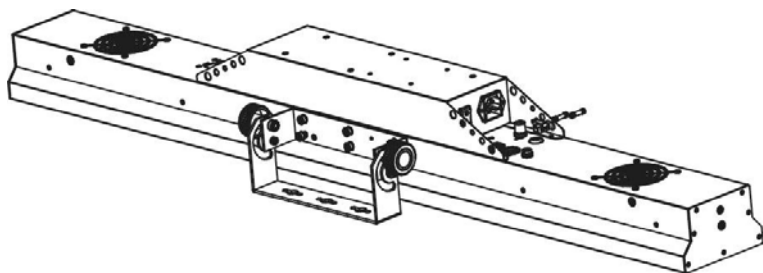

### 4. How to Set the Unit

#### 4.1 Control Panel

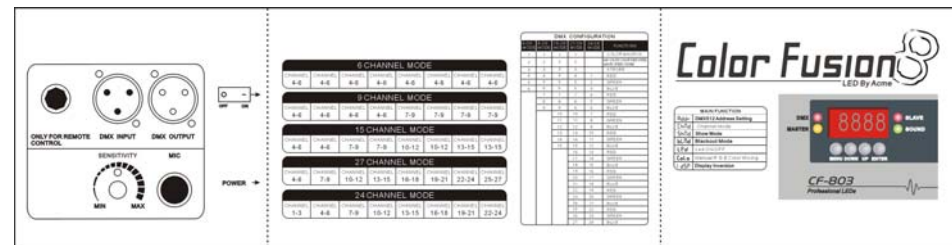

#### Display

To show the menu and selected function

#### LED

DMX	On	DMX input present
MASTER	On	Master mode
SLAVE	On	Slave mode
SOUND	Flashing	Sound activation

#### Button

MENU	To select the programming functions
DOWN	To go backward in the selected functions
UP	To go forward in the selected functions
ENTER	To confirm the selected functions

#### Remote controller input

By connecting to the 1/4" microphone jack to control the unit via Stand by, Function, and Mode function.

#### Sensitivity

To adjust the sound sensitivity

#### Microphone

To receive audio signal for sound activated.

#### DMX input/output

For DMX 512 link, use 3-pin XLR plug cable to link the unit together.

## 4.2. Main Function

To select any of the pre-set functions, press the **MENU** button until the required one is shown on the display. Select the function by **ENTER** button and the display will blink. Use **DOWN** and **UP** button to change the mode. Once the required mode has been selected, press the **ENTER** button to setup or it will automatically return to the main functions without any change after idling 8 seconds. To go back to the functions without any change press the **MENU** button. The main functions are shown below:

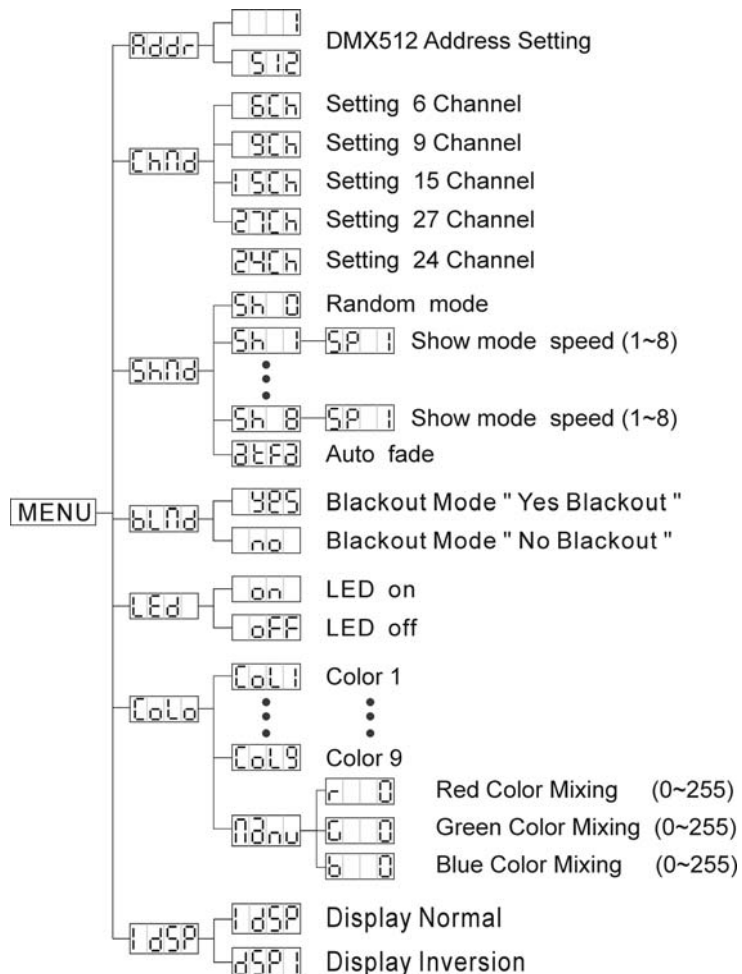

### Addr

#### DMX 512 Address Setting

Press the **MENU** button until the **Addr** is shown on the display. Pressing **ENTER** button and the display will blink. Use **DOWN** and **UP** button to change the DMX 512 address. Once the address has been selected, press the **ENTER** button to setup or automatically return to the main functions without any change after 8 seconds. To go back to the functions without any change press the **MENU** button again.

### Chnd

#### 6, 9, 15, 27, 24 Channel Mode

Press the **MENU** button until the **Chnd** is shown on the display. Pressing **ENTER** button and the display will blink. Use **DOWN** and **UP** button to select the 6-ch, 9-ch, 15-ch, 27-ch or 24-ch Channel Mode. Once the mode has been selected, press the **ENTER** button to setup or automatically return to the main functions without any change after 8 seconds. To go back to the functions without any change press the **MENU** button again.

### Shnd

#### Show Mode

Press the **MENU** button until the **Shnd** is showing on the display. Pressing **ENTER** button and the display will blink. Use **DOWN** and **UP** button to select the **Sh 0** (random mode) or **Sh 1** (show 1) ... **Sh 8** (show 8) or **At Fa** (auto fade) mode. Once the mode has been selected, press the **ENTER** button to setup or automatically return to the main functions without any change after 8 seconds. To go back to the functions without any change press the **MENU** button again.

In show mode, you can press the **Enter** button to set the chase speed (1~8).

### blnd

#### Blackout Mode

Press the **MENU** button until the **blnd** is shown on the display. Pressing **ENTER** button and the display will blink. Use **DOWN** and **UP** button to select the **Yes** (yes blackout) or **no** (no blackout) mode. Once the mode has been selected, press the **ENTER** button to setup or automatically return to the main functions without any change after 8 seconds. To go back to the functions without any change press the **MENU** button again.



### Led Display

Press the **MENU** button until the is showing on the display. Pressing **ENTER** button and the display will blink. Use **DOWN** and **UP** button to select the (Led on) or (Led off) mode. Once the mode has been selected, press the **ENTER** button to setup or automatically return to the main functions without any change after 8 seconds. To go back to the functions without any change press the **MENU** button again.

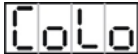

### Color Mode

Press the **MENU** button until the is showing on the display. Pressing **ENTER** button and the display will blink. Use **DOWN** and **UP** button to select the (color 1) or ... (color 9) or (manual color) mode. Once the mode has been selected, press the **ENTER** button to setup. Use **DOWN** and **UP** button to set the range. The setting will be store in the memory. To go back to the functions without any change press the **MENU** button again.

In manual color mode, you can use **DOWN** and **UP** button to set the

(Red 0~255)

(Green 0~255)

(Blue 0 ~255)



### Display Inversion

It is good for you to install the unit on the floor or under ceiling. Press the **MENU** button until the is blinking on the display. Use the **ENTER** button to change to the mode (display inversion), It will automatically store after 8 seconds. Or press the **ENTER** button again return to the mode (display normal). To go back to the functions press the **MENU** button.

Display normal mode for the fixture putting on the floor.

Display inversion mode for the fixture fixing under ceiling.

## 5. DMX512 Address Setting

### A. By LED Display Panel

- Each fixture needs to have an address setting to receive the data sent from the controller. The address number is between 0-511 (usually 0 & 1 are equal to 1). The address, also know as the start channel, is the first channel used to receive instructions the controller.
- The fixture uses six channels. (Fixture 1 = 1, Fixture 2 = 7, Fixture 3 = 13, Fixture 4 = 19, Fixture...)
- No need to turn the fixture off when you change the DMX address, as new DMX address setting will be effected at once. Every time you turn the fixture on, it will be ready to receive DMX signal or run the built-in programs.

### B. By CA-T DMX TESTER

The fixture can be set the DMX address remotely by *CA-T DMX TESTER*. Please refer to the CA-T user manual to set the DMX address to the fixture.

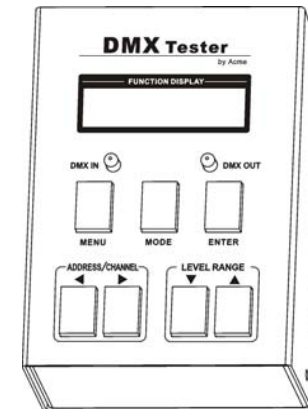

### C. By Universal DMX controller

The fixtures can be remote setting DMX address by universal DMX controller. First, programming two scenes into one chase and then link the fixtures to the universal DMX controller. When you run the chase, all series fixtures will set start DMX address automatically.

In the two scenes, Ch1 and Ch2 for auto DMX address setting mode, the values will never change. Ch3 and Ch4 for setting the DMX address, Ch3 or Ch4 value must be setting value together. Ch3 will be only set 0 or 1 and Ch4 will be set from 0 to 255.

$$\text{DMX start address} = (\text{Ch3} \times 256) + \text{Ch4} + 1$$

#### For example 1 :

Setting the four fixtures with DMX start address = 1

1. Edit the scene 1 → Ch1=0, Ch2=255, Ch3=0, Ch4=0
2. Edit the scene 2 → Ch1=255, Ch2=0, Ch3=0, Ch4=0
3. Programming two scenes into a chase and link the fixtures to the universal DMX controller.
4. Running the chase and all series fixtures will be setting start DMX address automatically.

#### For example 2 :

Setting the four fixtures with DMX start address = 10

1. Edit the scene 1 → Ch1=0, Ch2=255, Ch3=0, Ch4=9
2. Edit the scene 2 → Ch1=255, Ch2=0, Ch3=0, Ch4=9
3. Programming two scenes into a chase and link the fixtures to the universal DMX controller.
4. Running the chase and all series fixtures will be setting start DMX address automatically.

#### For example 3 :

Setting the four fixtures DMX start address = 257

1. Edit the scene 1 → Ch1=0, Ch2=255, Ch3=1, Ch4=0
2. Edit the scene 2 → Ch1=255, Ch2=0, Ch3=1, Ch4=0
3. Programming two scenes into a chase and link the fixtures to the universal DMX controller.
4. Running the chase and all series fixtures will be setting start DMX address automatically.

## 6. How to control the fixture

There are three ways to set-up the DMX address:

- A. Universal DMX controller
- B. Master/Slave operation
- C. Easy controller (by CA-8)

### A. Universal DMX controller

The user need to set the lighting channel mode first while control by universal DMX controller. The fixture has four kinds of channel modes (6-ch, 9-ch, 15-ch, 27-ch, 24-ch). It can set the channel mode from its LED display panel. Please refer to the following diagram to use your controller to activate the fixture.

DMX CONFIGURATION					
6-CH MODE	9-CH MODE	15-CH MODE	27-CH MODE	24-CH MODE	FUNCTIONS
1	1	1	1		COLOR MACROS
2	2	2	2		MIX-COLOR / COLOR FADE SPEED MACRO SPEED / SOUND
3	3	3	3		STROBE
4	4	4	4	1	RED
5	5	5	5	2	GREEN
6	6	6	6	3	BLUE
	7	7	7	4	RED
	8	8	8	5	GREEN
	9	9	9	6	BLUE
		10	10	7	RED
		11	11	8	GREEN
		12	12	9	BLUE
		13	13	10	RED
		14	14	11	GREEN
		15	15	12	BLUE
			16	13	RED
			17	14	GREEN
			18	15	BLUE
			19	16	RED
			20	17	GREEN
			21	18	BLUE
			22	19	RED
			23	20	GREEN
			24	21	BLUE
			25	22	RED
			26	23	GREEN
			27	24	BLUE

DMX512 Configuration									
Ch1	Ch2		Ch3	Ch4	Ch5	Ch6			
Color Marcos	RGB Mix/ Color Fade speed	Marco Speed/ Sound	Strobe	Red	Green	Blue			
227-255 Color Marco 8	255	255	255	255	255	255			
199-226 Color Marco 7	Fast Color Fade Speed	Sound	Fast	100%	100%	100%			
171-198 Color Marco 6		243					242		
142-170 Color Marco 5		Fast					///	///	///
114-141 Color Marco 4		16					16	16	16
086-113 Color Marco 3	15	15	15	15	15				
057-085 Color Marco 2	0	0	0	0	0	0			
029-056 Color Marco 1	0	0	0	0	0	0			
000-028 Color Fade	0	0	0	0	0	0			

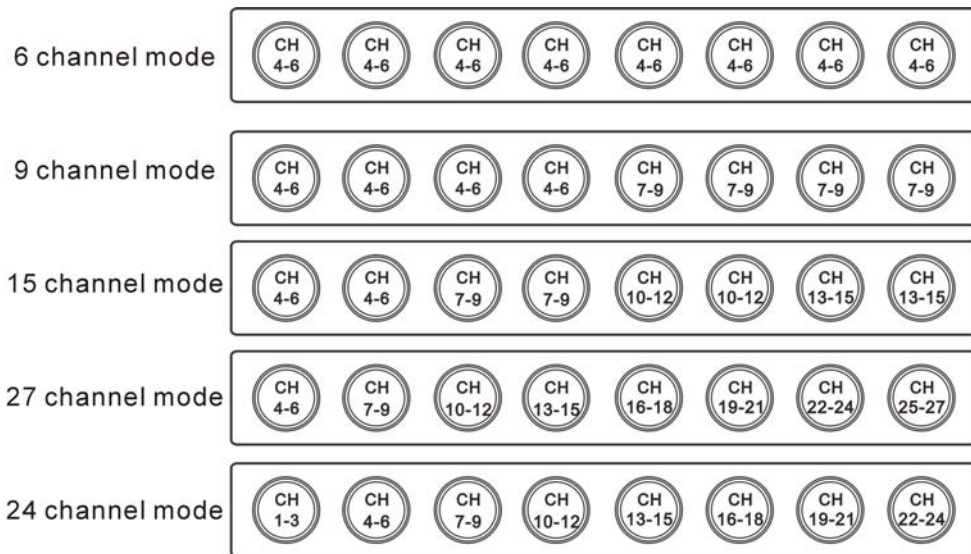

### B. Master/Slave operation

The fixtures will allow you to link others fixtures together and operate without a controller. In Master/Slave mode, the first fixture will control the others to give an automatic, sound activated, synchronized light show. This function is good when you want an instant show. The first unit it's DMX input cable will have nothing connect it, and the other fixtures will be set in slave mode automatically. Their DMX input cables connect the last fixture DMX output cable (daisy chain). Any fixture can act as a Master or as a Slave. Please refer to the following diagram to link the others fixtures.

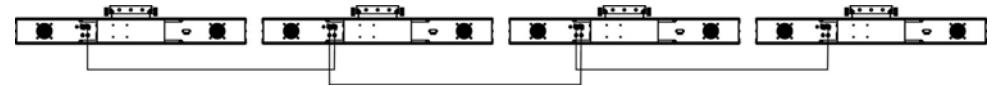

### C. Easy Controller (by CA-8)

The easy remote control is used only in master/slave mode. There is a terminator for connect the easy controller inside the fixture. By connecting the cable into DMX IN waterproof cable entry gland to the CA-8 terminator of the first fixture, you will find that the remote control on the first fixture will control all the other fixtures for Stand by, Function and Mode functions.

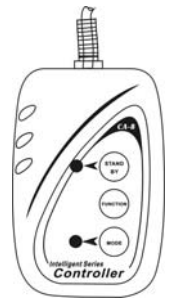

Blackout	To blackout all the fixture			
Function	Strobe	Select 9 Colors	Select 9 Show modes	Setting speed
	1. Synchronous strobe in white 2. Synchronous strobe in rainbow 3. Synchronous sound in white 4. Synchronous sound in rainbow	1. Red 2. Orange 3. Yellow 4. Green 5. Cyan 6. Blue 7. Purple 8. Magenta 9. White	1. Show 1 2. Show 2 3. Show 3 4. Show 4 5. Show 5 6. Show 6 7. Show 7 8. Show 8 9. Auto fade	1. Slow speed 2. Middle speed 3. Fast speed
Mode	Sound (LED OFF)	Latch (LED on)	Chase (LED blink)	Speed (LED Fast blink)

## 7. DMX512 Connection

The DMX 512 is widely used in intelligent lighting control, with a maximum of 512 channels.

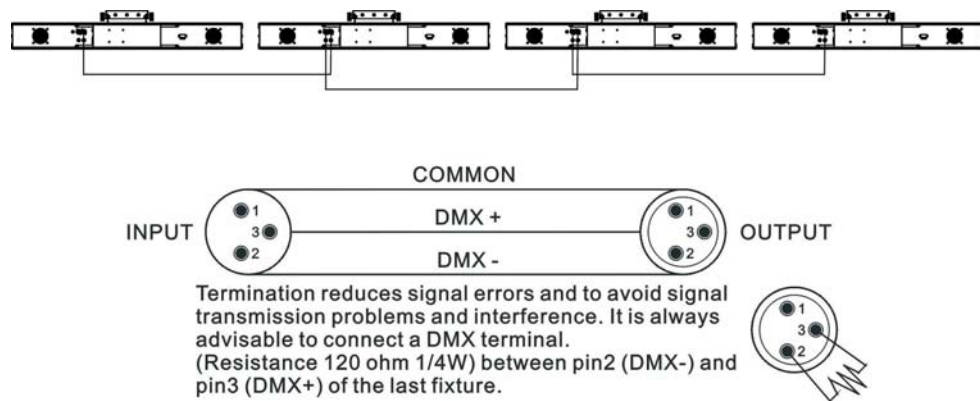

1. Connect the unit together in a “daisy chain” by XLR plug cable from the output of the unit to the input of the next unit. The cable cannot be branched or split to a “Y” cable. Inadequate or damaged cables, soldered joints or corroded connectors can easily distort the signal and shut down the system
2. The DMX output and input connectors are pass-through to maintain the DMX circuit when no power is connected to the fixture.
3. At last fixture, the DMX cable has to be terminated with a terminator to reduce signal errors. Solder a 120-ohm 1/4W resistor between pin 2(DMX-) and pin 3(DMX+) into a 3-pin XLR-plug and plug it in the DMX-output of the last fixture.
4. Each lighting unit needs to have an address set to receive the data sent by the controller. The address number is between 0-511 (usually 0 & 1 are equal to 1).
5. 3 pin XLR connectors are more popular than 5 pins XLR.  
3 pin XLR: Pin 1: GND, Pin 2: Negative signal (-), Pin 3: Positive signal (+)  
5pin XLR: Pin 1: GND, Pin 2: Negative signal (-), Pin 3: Positive signal (+)

## 8. Fixture Cleaning

The cleaning of internal must be carried out periodically to optimize light output. Cleaning frequency depends on the environment in which the fixture operates: damp, smoky or particularly dirty surrounding can cause greater accumulation of dirt on the fixture's optics.

- Clean with soft cloth using normal glass cleaning fluid.
- Always dry the parts carefully.
- Clean the external optics at least every 20 days. Clean the internal optics at least every 30/60 days.

# Innovation, Quality, Performance