

elumen8

Evora 850 Zoom Spot

V1.0.7

User Manual



Order codes: ELUM025

WARNING

FOR YOUR OWN SAFETY, PLEASE READ THIS USER MANUAL CAREFULLY BEFORE YOUR INITIAL START-UP!

- Before your initial start-up, please make sure that there is no damage caused during transportation.
- Should there be any damage, consult your dealer and do not use the equipment.
- To maintain the equipment in good working condition and to ensure safe operation, it is necessary for the user to follow the safety instructions and warning notes written in this manual.
- Please note that damages caused by user modifications to this equipment are not subject to warranty.



IMPORTANT:

The manufacturer will not accept liability for any resulting damages caused by the non-observance of this manual or any unauthorised modification to the equipment.

- Never let the power cable come into contact with other cables. Handle the power cable and all mains voltage connections with particular caution!
- Never remove warning or informative labels from the unit.
- Do not open the equipment and do not modify the unit.
- Do not connect this equipment to a dimmer pack.
- Do not switch the equipment on and off in short intervals, as this will reduce the system's life.
- Only use the equipment indoors.
- Do not expose to flammable sources, liquids or gases.
- Always disconnect the power from the mains when equipment is not in use or before cleaning! Only handle the power-cable by the plug. Never pull out the plug by pulling the power-cable.
- Make sure that the available mains supply voltage is between 100~240V AC, 50/60Hz.
- Make sure that the power cable is never crimped or damaged. Check the equipment and the power cable periodically.
- If the equipment is dropped or damaged, disconnect the mains power supply immediately and have a qualified engineer inspect the equipment before operating again.
- If the equipment has been exposed to drastic temperature fluctuation (e.g. after transportation), do not connect power or switch it on immediately. The arising condensation might damage the equipment. Leave the equipment switched off until it has reached room temperature.
- If your product fails to function correctly, stop use immediately. Pack the unit securely (preferably in the original packing material), and return it to your Prolight dealer for service.
- Only use fuses of same type and rating.
- We recommend this fixture should be serviced at least once every 3 months to prevent build-up of dust, dirt and debris that could affect the fixtures operation.
- Repairs, servicing and power connection must only be carried out by a qualified technician. THIS UNIT CONTAINS NO USER SERVICEABLE PARTS.
- This lighting fixture is for professional use only - it is not designed for or suitable for household use. The product must be installed by a qualified technician in accordance with local territory regulations. The safety of the installation is the responsibility of the installer. The fixture presents risks of severe injury or death due to fire hazards, electric shock and falls.
- Warning! Risk Group 2 LED product according to EN 62471. Do not view the light output with optical instruments or any device that may concentrate the beam.
- High power lighting fixtures are capable of producing powerful, concentrated beams of light that can create a fire hazard or a risk of eye injury if the safety precautions are not followed.
- WARRANTY: Two years from date of purchase.

OPERATING DETERMINATIONS

If this equipment is operated in any other way, than those described in this manual, the product may suffer damage and the warranty becomes void. Incorrect operation may lead to danger e.g: short-circuit, burns and electric shocks etc. Do not endanger your own safety and the safety of others!

Incorrect installation or use can cause serious damage to people and/or property.

This fixture falls under Protection Class 1, therefore it has to be connected to a mains socket with a protective earthing connection.

Risk group 2, RG-2: CAUTION!

Do not stare at exposed LED in operation as it may damage/be harmful to the eyes. Avoid looking directly into the light source.

CAUTION!

The maximum ambient temperature (T_a) of 40° must not be exceeded.

CAUTION!

If the lens gets damaged ie. cracks or deep scratches so the output is impaired then it must be replaced.

CAUTION!

To avoid damage to internal parts ie. optics, colour filters, gobos, prisms, frost filters, iris, shutters, motors, belts, wiring or LEDs never expose the front lens to direct sunlight, lighting fixtures or lasers even when the fixture is not in use.

Evora 850 Zoom Spot

Evora 850 Zoom Spot boasts a comprehensive list of features all contained in a compact, lightweight housing. The 200W LED generates an impressive output creating perfectly focused gobo projections as well as superb aerial effects. A DMX controlled motorised focus ensures that projections are always sharp over any distance and the motorised zoom function can remotely change the beam angle between 11° - 22°. These two features combined allow the fixture to be perfectly suited to both large and small venues.

- 1 x 200W white LED (20,500K)
- Adjustable beam angle: 11° - 22°
- Lumens - Source: 13,000
- Lumens - Output: 7,109
- 11° - 36,853 Lux @ 2m,
22° - 18,819 Lux @ 2m
- 3.5kHz refresh rate
- Motorised zoom and focus
- 6 facet circular rotating indexable prism plus
5 facet linear rotating indexable prism
- Gobo wheel 1: 6 rotating, indexable,
replaceable gobos + open
- Gobo wheel 2: 6 static gobos + open
- Colour wheel: 8 colours + open
- DMX channels: 17/23 or 24 selectable
- RDM (Remote Device Management)
- Auto, sound active, manual control
and master/slave modes
- Pan/tilt auto correction
- 16-Bit pan/tilt positioning
- Pan: 540°, Tilt: 270°
- 0-100% dimming and variable strobe
- Quick release omega clamps included
- 6 push button menu with 1.8" LCD display
- Display battery backup for offline configuration
- PowerCON input/output
- 3-Pin XLR input/output
- 5-Pin XLR input/output
- Fan cooled



Specifications	Evora 850 Zoom Spot
Power consumption	233W
Fuse	T3A 250V
Power supply	100~240V, 50/60Hz
Dimensions	470 x 295 x 180mm
Weight	10.6kg
Order code	ELUM025

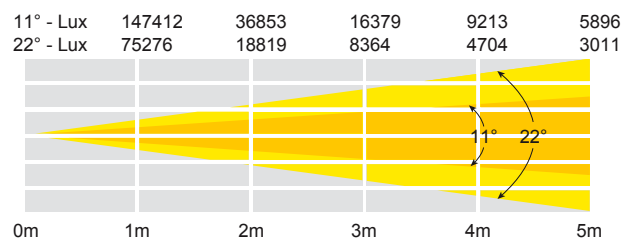

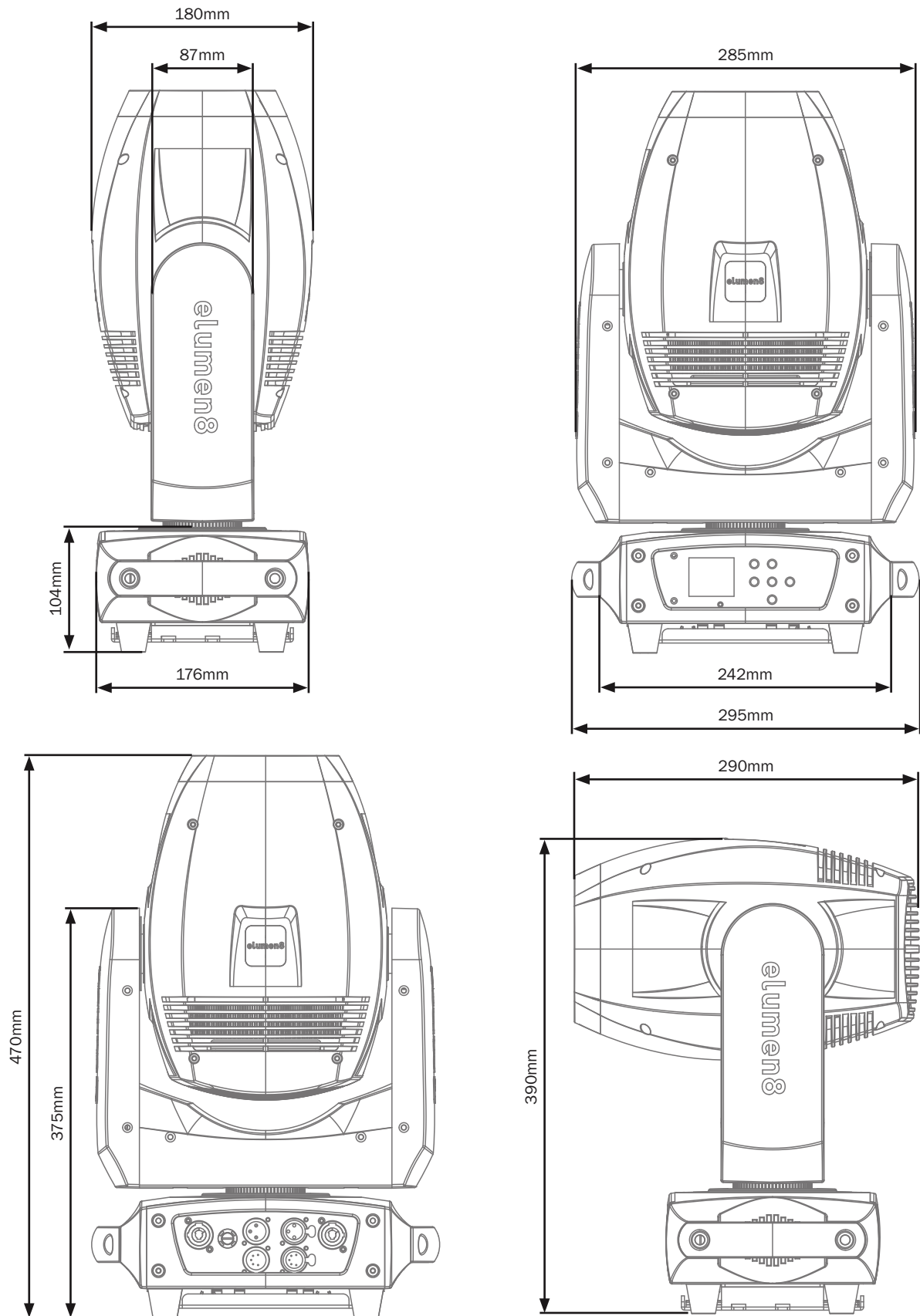

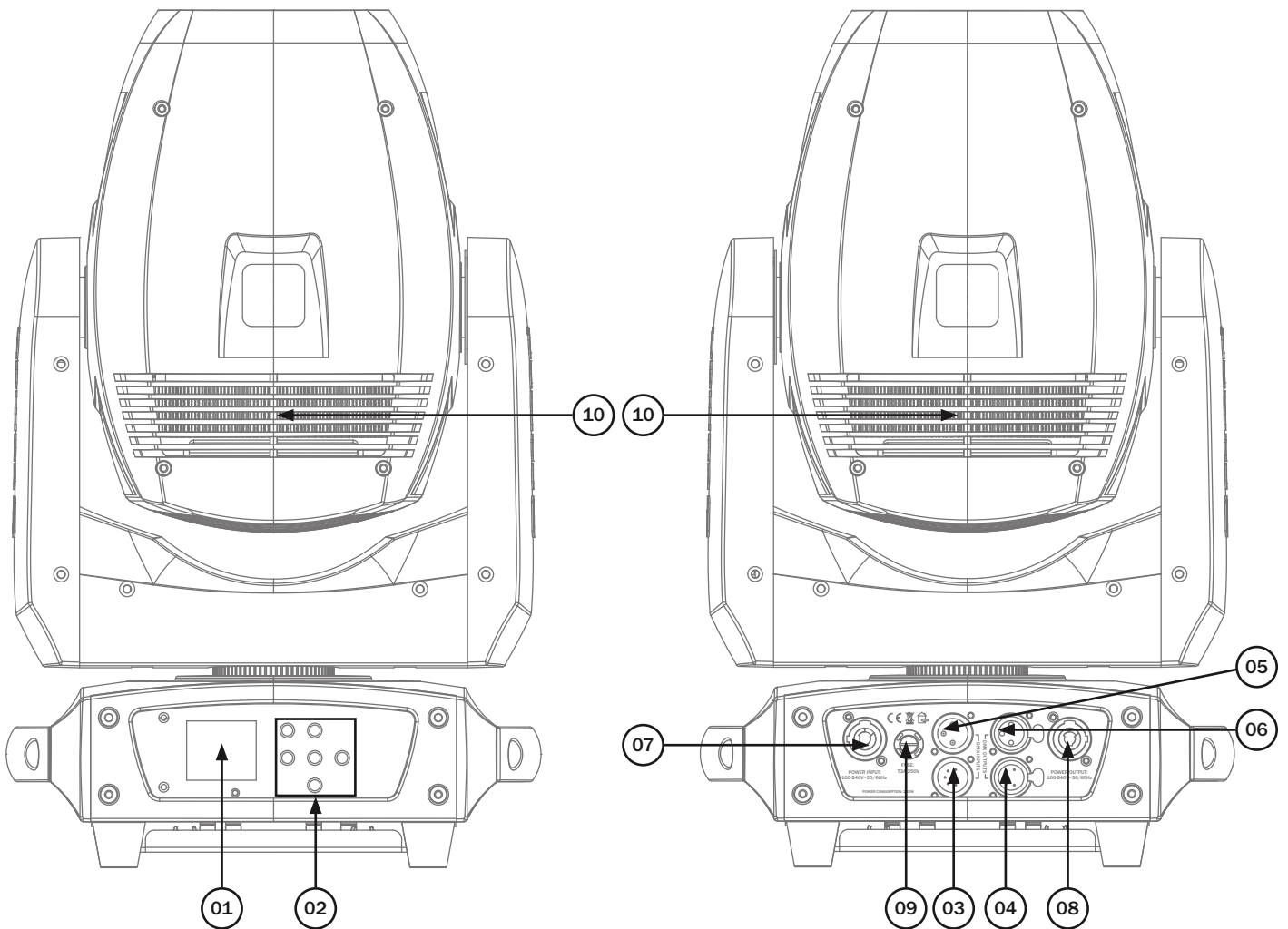

- 01 - LCD display
- 02 - Function buttons
- 03 - 5-Pin DMX input
- 04 - 5-Pin DMX output

- 05 - 3-Pin DMX input
- 06 - 3-Pin DMX output
- 07 - PowerCON input
- 08 - PowerCON output

- 09 - Fuse T3A 250V
- 10 - Fans

In the box: **1 x fixture,**
2 x omega clamps,
1 x power cable
& 1 x user manual

Before installing the fixture, the supporting structure (ie. truss) must be able to hold a minimum of 10 times the fixtures weight without any deformation (eg. 15kg - 150kg point load). The fixture must be secured with a secondary safety attachment when being installed (ie. an appropriate safety cable). Never stand directly below the fixture when mounting, removing, and/or servicing.

Overhead installation requires experience and qualifications to calculate working load limits, the material being used at the installation area and periodic safety inspections of the fixture and installation material. If you do not have the relevant experience and/or qualifications please do not attempt the installation yourself. The installation should be checked annually by a qualified person.

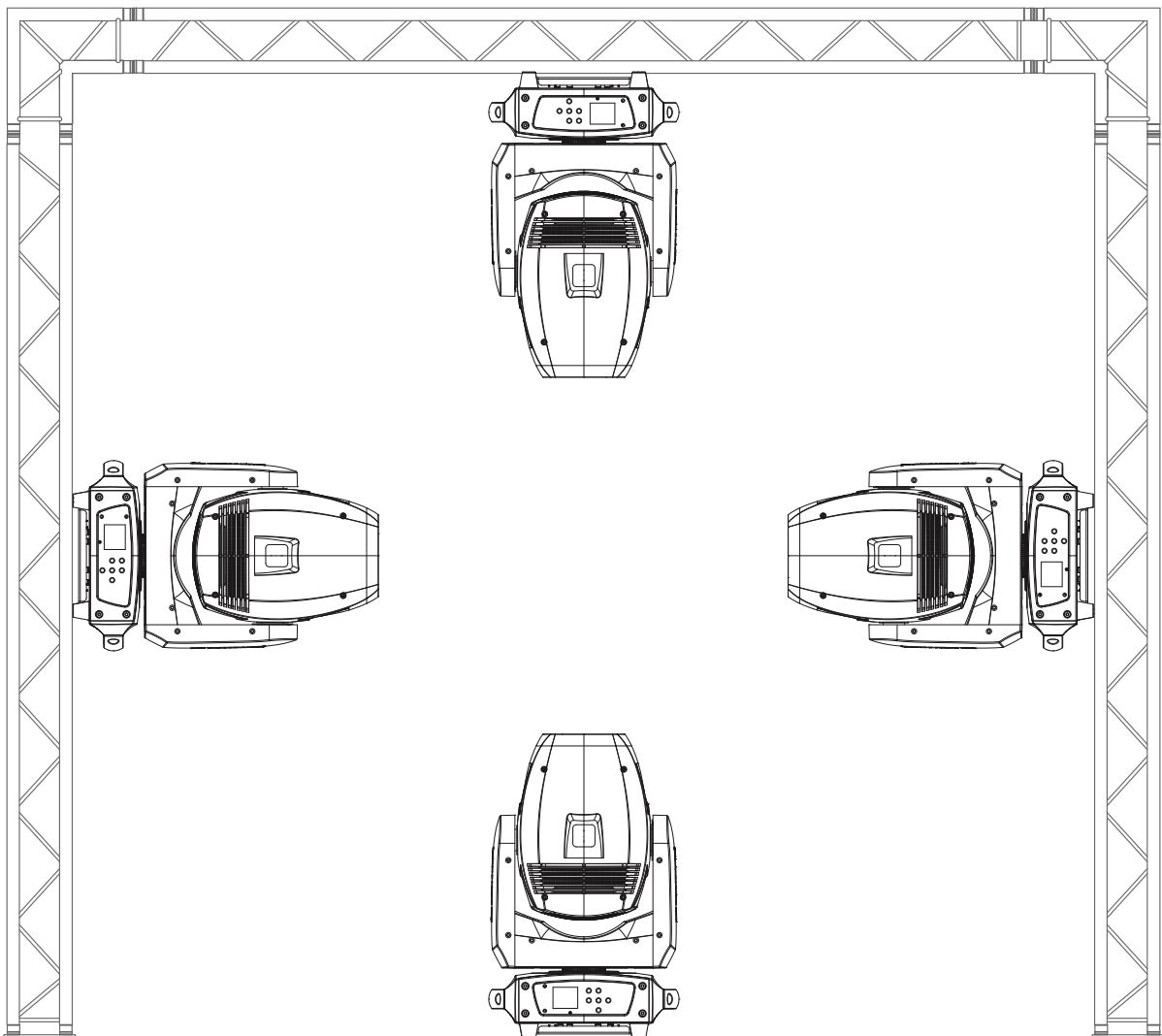

The eLumen8 Evora 850 Zoom Spot can be operated in a number of mounting positions as shown in the diagram above, hanging upside-down from the ceiling or truss, mounting sideways on truss or stood upright on a flat level surface. Always use a safety wire as an extra safety precaution to prevent damage/injury in the event a clamp fails (see the next page for clamp installation). Never use the carry handles for secondary attachments.

Installation:

1. Fasten each clamp to the omega clamps with a bolt and lock nut through the hole in the omega clamp.
2. Align and insert the omega clamp quick-lock fasteners with the respective holes on the bottom of the unit.
3. Tighten both locking fasteners clockwise on each omega clamp ensuring they're fully secure.
4. Mount the fixture onto your truss system via the clamps and tighten to ensure secure.
5. Pull the safety cable through the safety cable holes located on the metal base plate on the underside of the fixture and around the truss.

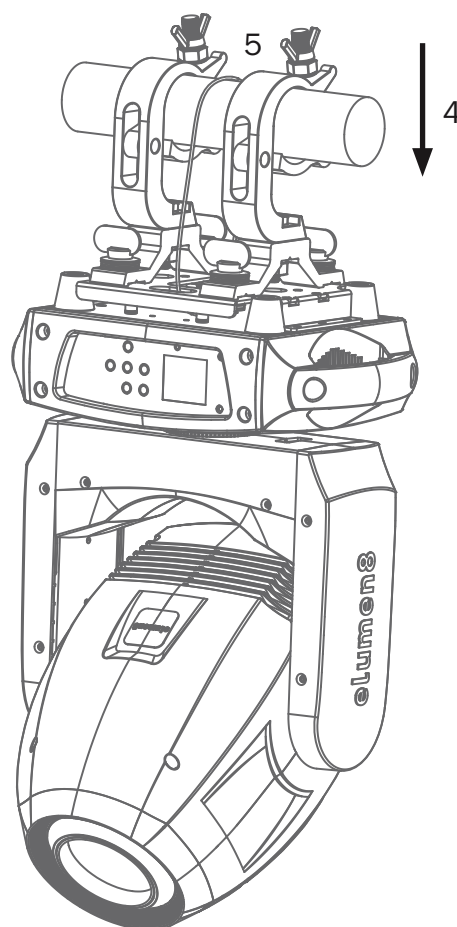
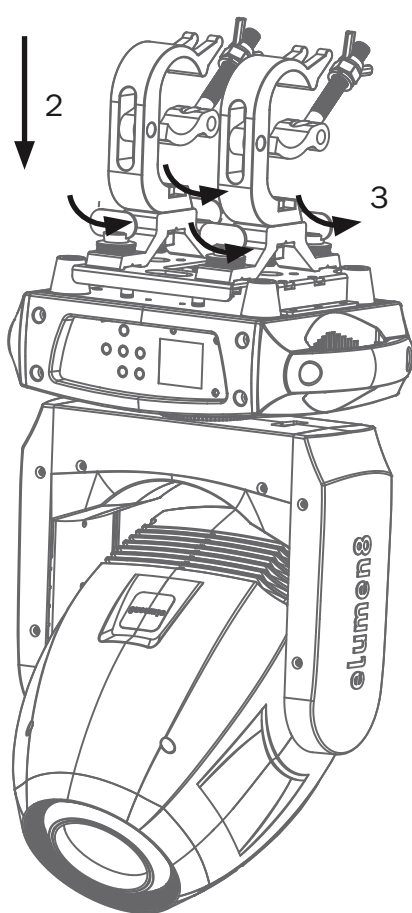
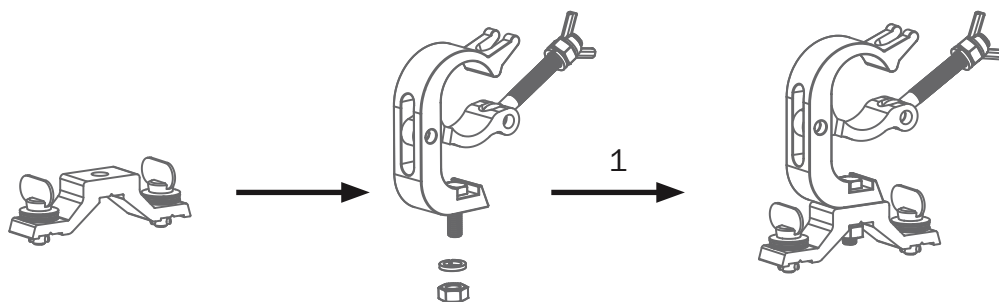

Control Panel Menu:

The LCD control panel situated on the front of the fixture allows the user to access the menu system to adjust the fixtures settings.

When the unit has been powered on the display will show “**Software up**” followed by “**eLumen8 Evora 850 Zoom Spot**” and “**Motor Reset Please Wait...**”. The fixture will then return to its home screen.

Pressing the “**MENU**” button once will take the user to the fixtures main menu. Using the “**UP**” and “**DOWN**” buttons you can then navigate between the different options in the main menu. Pressing the “**ENTER**” button on one of these options allows you to access the sub menu where you can use the “**LEFT**” and “**RIGHT**” buttons to select option/value required. Once the option/value has been selected press the “**ENTER**” button once more to confirm the setting.

To exit out of any of the above options, press and hold the “**MENU**” button.

The LCD control panel can be used via the internal battery. To access this press and hold the “**MENU**” button for 5 seconds until the fixtures home screen is displayed. The LCD display will automatically shut off after 20 seconds of inactivity.

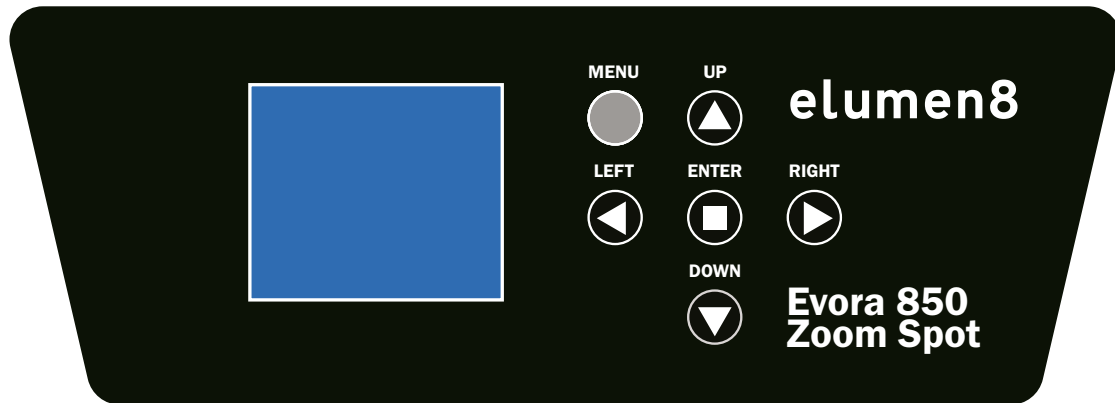

Error Codes:

When the unit is powered on the unit will automatically perform a motor reset. If there is a problem with any of the motors the display will flash and display “**Error:**” along with a list of motor errors on the LCD control panel. Please power the unit off and on to reset the motors again.

(The full list of errors codes can be found on the next page).

Error Code	Description
Pan	The PAN movement is not located in the default position after the reset. This message will appear if the sensor has failed or magnet is missing, or if there is a motor failure (defective motor or a defective motor IC drive on the main PCB). This error may also be displayed if the yoke was blocked during a reset function.
Tilt	The TILT movement is not located in the default position after the reset. This message will appear if the sensor has failed or magnet is missing, or if there is a motor failure (defective motor or a defective motor IC drive on the main PCB). This error may also be displayed if the head was blocked during a reset function.
Colorwheel	The colour wheel is not located in the default position after the reset. This message will appear if the sensor has failed or magnet is missing, or if there is a motor failure (defective motor or a defective motor IC drive on the main PCB).
Gobowheel 1	The gobo wheel is not located in the default position after the reset. This message will appear if the sensor has failed or magnet is missing, or if there is a motor failure (defective motor or a defective motor IC drive on the main PCB).
Gobowheel 2	The gobo wheel is not located in the default position after the reset. This message will appear if the sensor has failed or magnet is missing, or if there is a motor failure (defective motor or a defective motor IC drive on the main PCB).
Prism Rot	The prism rotation is not located in the default position after the reset. This message will appear if the sensor has failed or magnet is missing, or if there is a motor failure (defective motor or a defective motor IC drive on the main PCB).
Focus	The focus is not located in the default position after the reset. This message will appear if the sensor has failed or magnet is missing, or if there is a motor failure (defective motor or a defective motor IC drive on the main PCB).
Zoom	The zoom is not located in the default position after the reset. This message will appear if the sensor has failed or magnet is missing, or if there is a motor failure (defective motor or a defective motor IC drive on the main PCB).
Fan1	Fan 1 is not working correctly. This message will appear if the fan has failed or there is something blocking the fan blades spinning.
Fan2	Fan 2 is not working correctly. This message will appear if the fan has failed or there is something blocking the fan blades spinning.
Temp	This message will appear if the sensor has failed or the fixtures temperature is too hot.

Main Menu	Sub Menu	Options/Values (Default Settings in BOLD)		Description
DMX Address	Set Address	001-512		DMX Address Setting
Channel Mode	User Mode	Basic (17 channel mode)		DMX Channel Setting/ User Defined Modes
		Standard (23 channel mode)		
		Extend (24 channel mode)		
		User A		
		User B		
	User C			
	Edit A	Max Chan	:	Edit User Defined Modes
Edit B				
Edit C	Reset/Prog			
Program			Show 1	Built-in Programs
			Show 2	
			Show 3	
			Show 4	
Manual Control	Pan	000-255		Manual Control Mode
	PanFine			
	Tilt			
	TiltFine			
	ColorWheel			
	Gobo1			
	Gobo1Rot			
	Gobo2			
	Strobe			
	Dimmer			
	DimmerFine			
	Zoom			
	ZoomFine			
	Focus			
	Prism1			
	Prism1Rot			
	Prism1Fine			
Prism2				
Prism2Rot				
Prism2Fine				
Function	Status	DMX Fail	Hold	DMX Fail Setting
			Blackout	
			Program	
		Sound State	OFF	Sound Setting
			ON	
		Sound Sense	000-100 (085)	Sound Sensitivity Setting

Main Menu	Sub Menu	Options/Values (Default Settings in BOLD)		Description
Function	Status	Focus Adj	000-255	Gobo 1 Focus Setting
		Focus2 Adj	000-255	Gobo 2 Focus Setting
		Zoom Adj	000-255	Zoom Adjust Setting
		Pan Inverse	OFF	Pan Inverse Setting
			ON	
		Tilt Inverse	OFF	Tilt Inverse Setting
			ON	
		Pan Degree	540	Pan Degree Setting
			630	
		Correction	OFF	P/T Auto Correction Setting
	ON			
	P/T Speed	Speed 1	P/T Speed Setting	
		Speed 2		
		Speed 3		
		Speed 4		
	Dormancy	OFF	Hibernation Setting	
		01M-099M		
	Dim Mode	Standard		Dimming Curve Mode Speed
		Stage		
		TV		
		Architectural		
		Theatre		
	Temp. C/F	Celsius		Temperature Setting
		Fahrenheit		
	Gamma	2.0		Gamma Brightness Setting
		2.2		
		2.4		
		2.8		
	Frequency	900Hz		LED Refresh Rate Setting
		1000Hz		
		1100Hz		
		1200Hz		
		1300Hz		
1400Hz				
1500Hz				
2500Hz				
Fan Set	Head Fan	Auto	Fan Speed Setting	
		High		
		Low		
LCD. Set	Backlight	02M-60M (05M)	LCD Backlight Setting	

Main Menu	Sub Menu	Options/Values (Default Settings in BOLD)		Description		
Function	LCD. Set	Flip Display	OFF	LCD Display Inverse Setting		
			ON			
		Key Lock	OFF	Control Panel Lock Setting (Press and hold MODE for 3 seconds to unlock)		
			ON			
		DispFlash	OFF	Display Flash Setting When No DMX Signal		
			ON			
	Disp.Set	Chan.Value	Pan	Value Of Each Channel Displayed		
			Pan Fine			
			Tilt			
			Tilt Fine			
			ColorWheel			
			Gobo 1			
			Gobo 1 Rot			
			Gobo 2			
			Strobe			
			Dimmer			
			Dimmer Fine			
			Zoom			
			Zoom Fine			
			Prism 1			
			Prism 1 Rot			
			Prism 1 Fine			
			Prism 2			
			Prism 2 Rot			
			Prism 2 Fine			
			Auto Pro			
			Dim Mode			
			P/T Speed			
			DeviceSet			
			Slave Set		Slave1	Slave Setting
					Slave2	
					Slave3	
			MasterSet		Master	Master Setting
Alone						
Information	Time. Info	CurrentTime	xxxH	Current Usage Time		
		Total Time	xxxH	Total Usage Time		
		Last Time	xxxH	Total Usage Time Since Last Clear		
		Time PIN	050 (Clear Last) 060 (Clear Total)	Clear Time PIN		
		Clear Last	OFF	Clear Last Time (PIN Required)		
ON						

Main Menu	Sub Menu	Options/Values (Default Settings in BOLD)	Description	
Information	Temp. Info	T: xxx °C	Temperature Information	
	Fan Speed	Fan1: xxxxRPM	Fan Speed Information	
		Fan2: xxxxRPM		
	Error. Info	NONE/Pan, Tilt...	Current Fixture Errors	
	Model. Info	Evora 850 Zoom Spot	Model Information	
Software.V	1U: Vx.x.xx 2U: Vx.x.xx 3U: Vx.x.xx	Software Version		
Test	Test Channel	Testing...	Auto Test	
Calibrate	Password (050)	Pan	000-255	Calibration Setting
		Tilt		
		Color		
		Gobo 1		
		Gobo 1 Rot		
		Gobo 2		
		Prism 1 (circular)		
		Prism 2 (linear)		
		Prism Rot		
		Focus		
		Zoom		
Reset	Motor Reset	All	Reset All Motors	
		Pan&Tilt	Reset Pan & Tilt Motors	
		Head	Reset Head Motors	
	DFSE	OFF	Default Factory Settings	
		ON		

Dimming Curve Ramp Effect	0 second fade time		1 second fade time	
	Rise time (ms)	Down time (ms)	Rise time (ms)	Down time (ms)
Standard (default)	0	0	0	0
Stage	780	1100	1540	1660
TV	1180	1520	1860	1940
Architectural	1380	1730	2040	2120
Theatre	1580	1940	2230	2280

DMX channel modes:

Channel			Value	Function
Basic	Standard	Extend		
1	1	1	000-255	Pan movement 630°/540° (8 bit)
-	2	2	000-255	Pan fine (16 bit)
2	3	3	000-255	Tilt movement (8 bit)
-	4	4	000-255	Tilt fine (16 bit)
3	5	5	000-005	Open
			006-011	Red
			012-017	Orange
			018-023	Yellow
			024-029	Green
			030-035	Blue
			036-041	Purple
			042-047	Cyan
			048-053	Magenta
			054-192	Colour Wheel Indexing
			193-223	Colour scroll CW (fast-slow)
			224-224	Colour scroll stop
			225-255	Colour scroll CCW (slow-fast)
4	6	6	000-005	Open
			006-020	Rotating gobo 1
			021-035	Rotating gobo 2
			036-050	Rotating gobo 3
			051-065	Rotating gobo 4
			066-080	Rotating gobo 5
			081-095	Rotating gobo 6
			096-110	Gobo 1 shake (slow-fast)
			111-125	Gobo 2 shake (slow-fast)
			126-140	Gobo 3 shake (slow-fast)
			141-155	Gobo 4 shake (slow-fast)
			156-170	Gobo 5 shake (slow-fast)
			171-185	Gobo 6 shake (slow-fast)
			186-192	Open
			193-223	Gobo wheel scroll CW (fast-slow)
			224	Gobo scroll stop
225-255	Gobo wheel scroll CCW (slow-fast)			

DMX channel modes:

Channel			Value	Function
Basic	Standard	Extend		
5	7	7	000-005	No function
			006-127	Gobo rotation index
			128-191	Gobo rotation CW (fast-slow)
			192-192	Rotation stop
			193-255	Gobo rotation CCW (slow-fast)
6	8	8	000-005	Open
			006-020	Gobo 1
			021-035	Gobo 2
			036-050	Gobo 3
			051-065	Gobo 4
			066-080	Gobo 5
			081-095	Gobo 6
			096-110	Gobo 1 shake (slow-fast)
			111-125	Gobo 2 shake (slow-fast)
			126-140	Gobo 3 shake (slow-fast)
			141-155	Gobo 4 shake (slow-fast)
			156-170	Gobo 5 shake (slow-fast)
			171-185	Gobo 6 shake (slow-fast)
			186-192	Open
			193-223	Gobo wheel scroll CW (fast-slow)
			224	Gobo scroll stop
225-255	Gobo wheel scroll CCW (slow-fast)			
7	9	9	000-031	LED off
			032-063	LED on
			064-095	Strobe (slow-fast)
			096-127	LED on
			128-159	Pulse strobe (slow-fast)
			160-191	LED on
			192-223	Random strobe (slow-fast)
			224-255	LED on
8	10	10	000-255	Dimmer (0-100%)
-	11	11	000-255	Dimmer fine (16 bit)
9	12	12	000-255	Zoom (narrow-wide)
-	13	13	000-255	Zoom fine (16 bit)
10	14	14	000-255	Focus

DMX channel modes:

Channel			Value	Function
Basic	Standard	Extend		
11	15	15	000-005	No function
			006-255	Prism 1 (6 facet circular)
12	16	16	000-127	Prism 1 indexing
			128-189	Prism 1 rotation CW (fast-slow)
			190-193	Prism 1 rotation stop
			194-255	Prism 1 rotation CCW (slow-fast)
-	17	17	000-255	Prism 1 indexing fine (6 facet circular)
13	18	18	000-005	No function
			006-255	Prism 2 (5 facet linear)
14	19	19	000-127	Prism 2 indexing
			128-189	Prism 2 rotation CW (fast-slow)
			190-193	Prism 2 rotation stop
			194-255	Prism 2 rotation CCW (slow-fast)
-	20	20	000-255	Prism 2 indexing fine (5 facet linear)
-	-	21	000-005	No function
			006-067	Show 1
			068-129	Show 2
			130-191	Show 3
15	21	22	0-20	Standard dimming mode
			21-40	Stage dimming mode
			41-60	TV dimming mode
			61-80	Architectural dimming mode
			81-100	Theatre dimming mode
			101-255	Default dimming mode (set on fixture)
16	22	23	000-255	Pan/tilt speed
17	23	24	000-005	No function
			006-015	Blackout while P/T on (hold 3s)
			016-025	Blackout while P/T off (hold 5s)
			026-035	Invert pan on (hold 3s)
			036-045	Invert pan off (hold 5s)
			046-055	Invert tilt on (hold 3s)
			056-065	Invert tilt off (hold 5s)
			066-205	No function
			206-215	Reset pan/tilt (hold 3s)
			216-225	Reset head only (hold 3s)
			226-235	Reset all motors (hold 3s)
236-255	No function			

Rotating gobos:

Gobo size: 22.9mmØ

Image size: 19mmØ



Gobo 1



Gobo 2

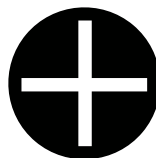

Gobo 3



Gobo 4



Gobo 5

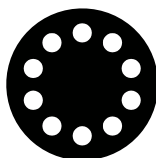

Gobo 6

Static gobos:



Gobo 1

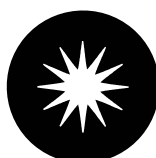

Gobo 2



Gobo 3



Gobo 4

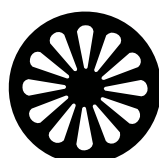

Gobo 5

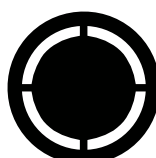

Gobo 6

Setting the DMX address:

The DMX mode enables the use of a universal DMX controller. Each fixture requires a “start address” from 1- 512. A fixture requiring one or more channels for control begins to read the data on the channel indicated by the start address. For example, a fixture that occupies or uses 7 channels of DMX and was addressed to start on DMX channel 100, would read data from channels: 100, 101, 102, 103, 104, 105 and 106. Choose a start address so that the channels used do not overlap. E.g. the next unit in the chain starts at 107.

DMX 512:

DMX (Digital Multiplex) is a universal protocol used as a form of communication between intelligent fixtures and controllers. A DMX controller sends DMX data instructions from the controller to the fixture. DMX data is sent as serial data that travels from fixture to fixture via the DATA “IN” and DATA “OUT” XLR terminals located on all DMX fixtures (most controllers only have a data “out” terminal).

DMX linking:

DMX is a language allowing all makes and models of different manufactures to be linked together and operate from a single controller, as long as all fixtures and the controller are DMX compliant. To ensure proper DMX data transmission, when using several DMX fixtures try to use the shortest cable path possible. The order in which fixtures are connected in a DMX line does not influence the DMX addressing. For example; a fixture assigned to a DMX address of 1 may be placed anywhere in a DMX line, at the beginning, at the end, or anywhere in the middle. When a fixture is assigned a DMX address of 1, the DMX controller knows to send DATA assigned to address 1 to that unit, no matter where it is located in the DMX chain.

DATA cable (DMX cable) requirements (for DMX operation):

This fixture can be controlled via DMX-512 protocol. The DMX address is set on the back of the unit. Your unit requires either a standard 3-pin or 5-pin XLR connector for data input/output, see images below.

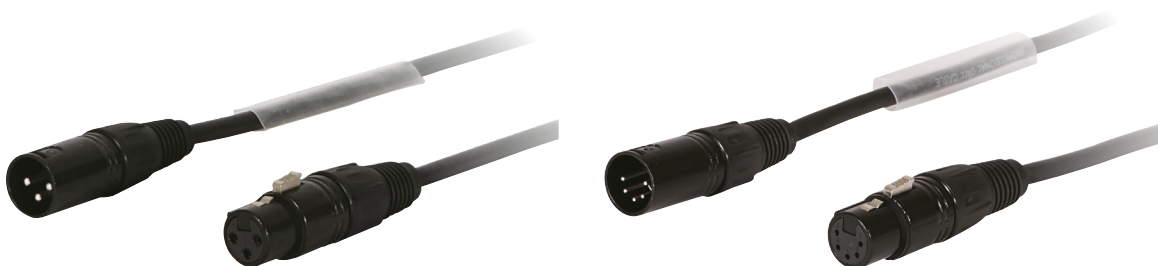

Further DMX cables can be purchased from all good sound and lighting suppliers or Prolight Concepts dealers.

Please quote:	3-Pin:	CABL10 – 2m	CABL11 – 5m	CABL12 – 10m
	5-Pin:	CABL185 – 2m	CABL187 – 5m	CABL188 – 10m

Also remember that DMX cable must be daisy chained and cannot be split.

Notice:

Be sure to follow the diagrams below when making your own cables. Do not connect the cables shield conductor to the ground lug or allow the shield conductor to come in contact with the XLRs outer casing. Grounding the shield could cause a short circuit and erratic behaviour.

Pin Configuration	
3-Pin	5-Pin
	Pin 1 - Ground
	Pin 2 - Negative
	Pin 3 - Positive
-	Pin 4 - N/C
-	Pin 5 - N/C

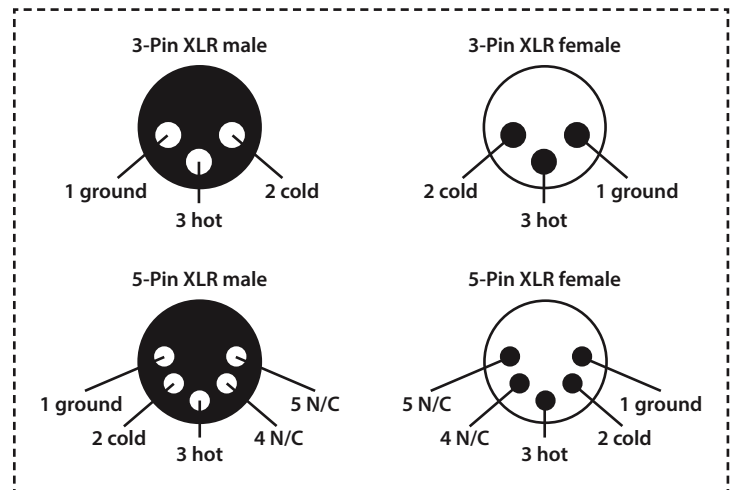
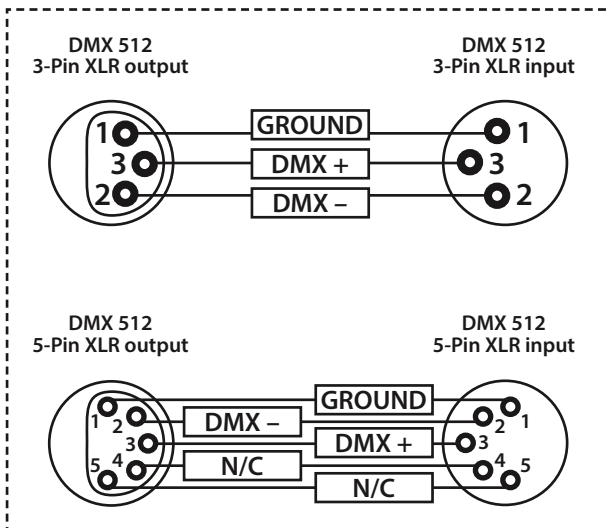

Line termination:

When longer runs of cable are used, you may need to use a terminator on the last unit to avoid erratic behaviour.

Using a cable terminator will decrease the possibilities of erratic behaviour.

(3-pin - Order ref: CABL90,
5-pin - Order ref: CABL89)

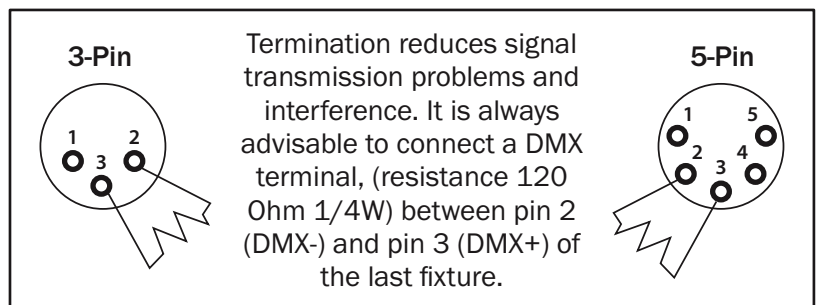

5-pin XLR DMX connectors:

Some manufactures use 5-pin XLR connectors for data transmission in place of 3-pin. 5-pin XLR fixtures may be implemented in a 3-pin XLR DMX line. When inserting standard 5-pin XLR connectors in to a 3-pin line a cable adaptor must be used. The diagram below details the correct cable conversion.

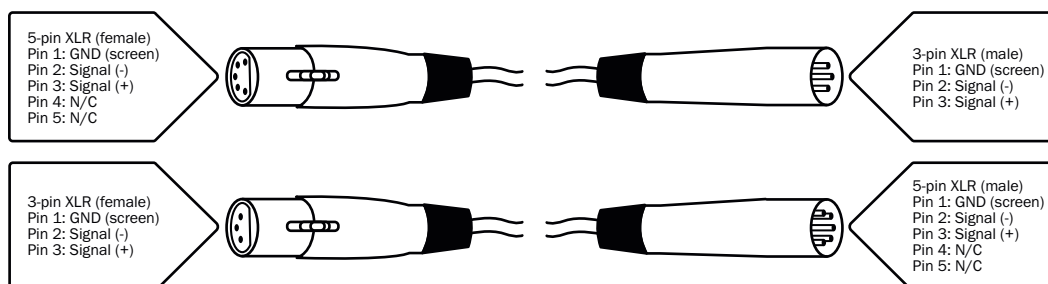

Power linking:

This fixture provides power linking via the power output on the rear allowing multiple units to be connected together. The maximum number of fixtures that can be connected is 8 fixtures @ 240V or 4 fixtures @ 120V (including the first fixture). After the maximum number of fixtures are connected a new power run will need to be started.

Please note: Caution should be used when power linking other fixtures to the Evora 850 Zoom Spot as the power consumption of other fixtures will vary. Fixtures fitted with lamps often require 2/3 times more current on startup, these may require their own power source.

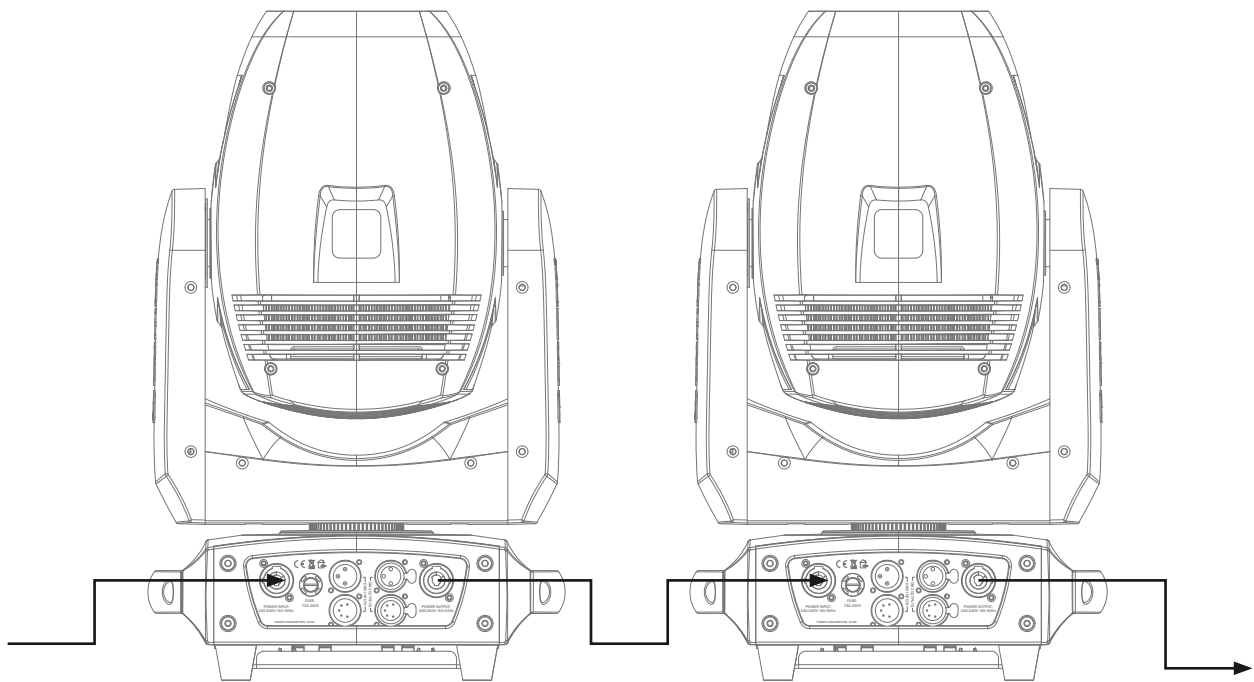



***Correct Disposal of this Product
(Waste Electrical & Electronic Equipment)***

**(Applicable in the European Union and other European countries
with separate collection systems)**

This marking shown on the product or its literature, indicates that it should not be disposed with other household wastes at the end of its working life. To prevent possible harm to the environment or human health from uncontrolled waste disposal, please separate this from other types of wastes and recycle it responsibly to promote the sustainable reuse of material resources.

Household users should contact either the retailer where they purchased this product, or their local government office, for details of where and how they can take this item for environmentally safe recycling.

Business users should contact their supplier and check the terms and conditions of the purchase contract. This product should not be mixed with other commercial wastes for disposal.

