

@Lumen8

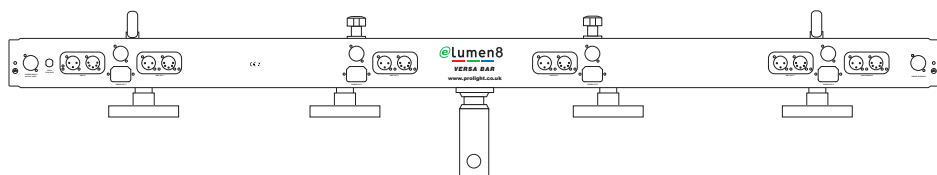

VERSA BAR

Code: ELUM075



WARNING

**FOR YOUR OWN SAFETY, PLEASE READ THIS USER MANUAL CAREFULLY
BEFORE YOUR INITIAL START-UP!**



CAUTION!

**Keep this equipment away from rain,
moisture and liquids.**



SAFETY INSTRUCTIONS

Every person involved with the installation, operation & maintenance of this equipment should:

- Be competent
- Follow the instructions of this manual



**CAUTION! TAKE CARE USING THIS EQUIPMENT!
HIGH VOLTAGE-RISK OF ELECTRIC SHOCK!!**



Before your initial start-up, please make sure that there is no damage caused during transportation. Should there be any, consult your dealer and do not use the equipment.

To maintain the equipment in good working condition and to ensure safe operation, it is necessary for the user to follow the safety instructions and warning notes written in this manual.

Please note that damages caused by user modifications to this equipment are not subject to warranty.

IMPORTANT:

The manufacturer will not accept liability for any resulting damages caused by the non-observance of this manual or any unauthorised modification to the equipment.

- Never let the power-cable come into contact with other cables. Handle the power-cable and all mains voltage connections with particular caution!
- Never remove warning or informative labels from the equipment.
- Do not open the equipment and do not modify the equipment.
- Do not switch the equipment on and off in short intervals, as this will reduce the system's life.
- Only use the equipment indoors.
- Do not expose to flammable sources, liquids or gases.
- Always disconnect the power from the mains when equipment is not in use or before cleaning! Only handle the power-cable by the plug. Never pull out the plug by pulling the power-cable.
- Make sure that the available voltage is between 220v/240v.
- Make sure that the power-cable is never crimped or damaged. Check the equipment and the power-cable periodically.
- If the equipment is dropped or damaged, disconnect the mains power supply immediately. Have a qualified engineer inspect the equipment before operating again.
- If the equipment has been exposed to drastic temperature fluctuation (e.g. after transportation), do not switch it on immediately. The arising condensation might damage the equipment. Leave the equipment switched off until it has reached room temperature.
- If your product fails to function correctly, discontinue use immediately. Pack the unit securely (preferably in the original packing material), and return it to your Prolight dealer for service.
- Only use fuses of same type and rating.
- Repairs, servicing and power connection must only be carried out by a qualified technician. THIS UNIT CONTAINS NO USER SERVICEABLE PARTS.
- WARRANTY; One year from date of purchase.

OPERATING DETERMINATIONS

If this equipment is operated in any other way, than those described in this manual, the product may suffer damage and the warranty becomes void.

Incorrect operation may lead to danger e.g.: short-circuit, burns, electric shocks, lamp failure etc.

Do not endanger your own safety and the safety of others!
Incorrect installation or use can cause serious damage to people and property.

Overview:

The Versa Bar from Elumen8 is designed to allow power & DMX distribution to LED lighting fixtures. The Versa Bar is not intended to control halogen fixtures.

You should find inside the Elumen8 carton the following items:

- 1, Versa Bar
- 2, Instruction manual,
- 3, Power Cable

Technical Specifications:

- 1 x powercon input socket
- 1 x powercon through socket
- 1 x 3 & 5-pin XLR input socket
- 1 x 3 & 5-pin XLR through socket
- 4 zones each comprising: Adjustable position fixture point, IEC & powercon output sockets, 3 & 5-pin XLR output sockets
- 100% electrical isolation between all inputs/outputs
- Each DMX output features an independent driver with DATA indicator
- Fused input and outputs
- 28mm spigot
- 2 adjustable hanging and safety points
- Max load: 40Kgs
- Power supply: 240V, 10A maximum
- Dimensions: 1504 x 65 x 160mm
- Weight: 4.6Kgs

Overview:

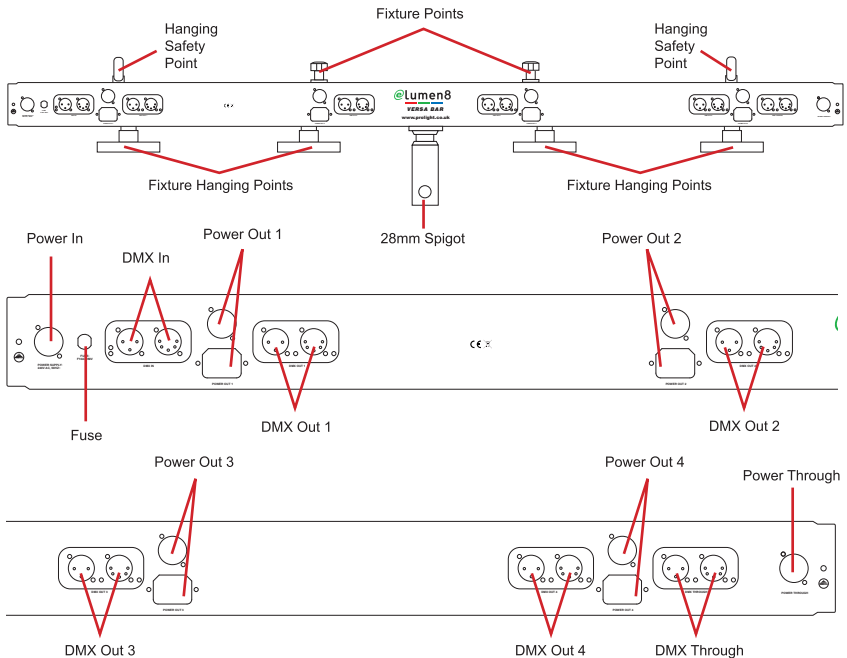

Operating instruction and connections

DMX

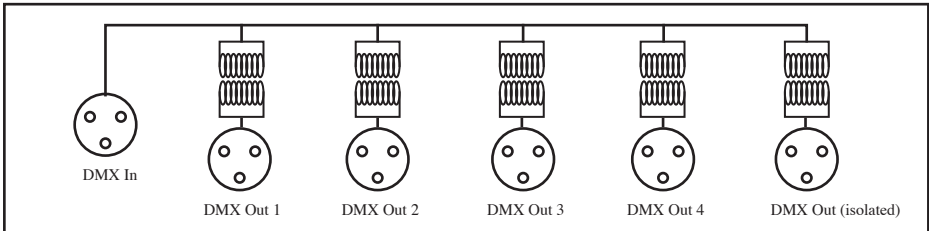

Power

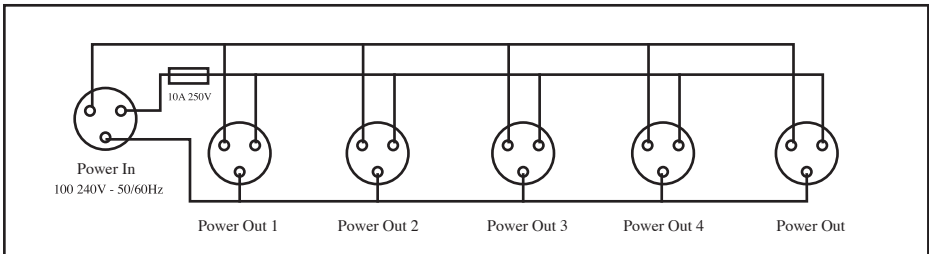

DMX Setup

DMX-512:

- DMX (Digital Multiplex) is a universal protocol used as a form of communication between intelligent fixtures and controllers. A DMX controller sends DMX data instructions from the controller to the fixture. DMX data is sent as serial data that travels from fixture to fixture via the DATA "IN" and DATA "OUT" XLR terminals located on all DMX fixtures (most controllers only have a data "out" terminal).

DMX Linking:

- DMX is a language allowing all makes and models of different manufacturers to be linked together and operate from a single controller, as long as all fixtures and the controller are DMX compliant. To ensure proper DMX data transmission, when using several DMX fixtures try to use the shortest cable path possible. The order in which fixtures are connected in a DMX line does not influence the DMX addressing. For example; a fixture assigned to a DMX address of 1 may be placed anywhere in a DMX line, at the beginning, at the end, or anywhere in the middle. When a fixture is assigned a DMX address of 1, the DMX controller knows to send DATA assigned to address 1 to that unit, no matter where it is located in the DMX chain.

DATA Cable (DMX cable) requirements (for DMX operation):

- The Versa Bar can be controlled via DMX-512 protocol. The DMX address is set on the back of the unit. Your unit and your DMX controller require a standard 3-pin XLR connector for data input/output (figure 1).

Figure 1



Further DMX cables can be purchased from all good sound and lighting suppliers or Proflight dealers. Please quote:
 CABL10 – 2M
 CABL11 – 5M
 CABL12 – 10M

Also remember that DMX cable must be daisy chained and cannot be split.

Notice:

- Be sure to follow figures 2 & 3 when making your own cables. Do not connect the cable's shield conductor to the ground lug or allow the shield conductor to come in contact with the XLR's outer casing. Grounding the shield could cause a short circuit and erratic behaviour.

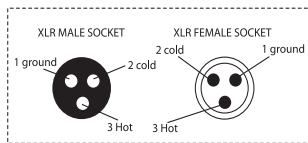
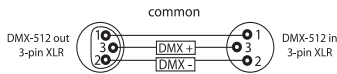

FIGURE 3

XLR Pin Configuration	
Pin 1 =	Ground
Pin 2 =	Negative
Pin 3 =	Positive

FIGURE 2

Special Note: Line termination:

- When longer runs of cable are used, you may need to use a terminator on the last unit to avoid erratic behaviour.

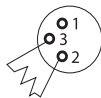

Termination reduces signal transmission problems and interference. It is always advisable to connect a DMX terminal, (resistance 120 Ohm 1/4 W) between pin 2 (DMX-) and pin 3 (DMX+) of the last fixture.

Using a cable terminator (part number CABL90) will decrease the possibilities of erratic behaviour.

5-Pin XLR DMX Connectors:

- Some manufactures use 5-pin XLR connectors for data transmission in place of 3-pin. 5-Pin XLR fixtures may be implemented in a 3-pin XLR DMX line. When inserting standard 5-pin XLR connectors in to a 3-pin line a cable adaptor must be used. The Chart below details the correct cable conversion.

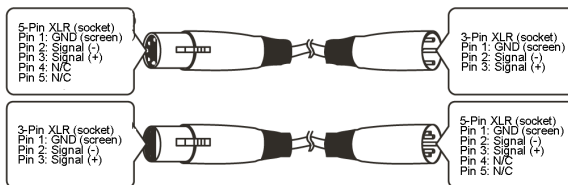

Notes:

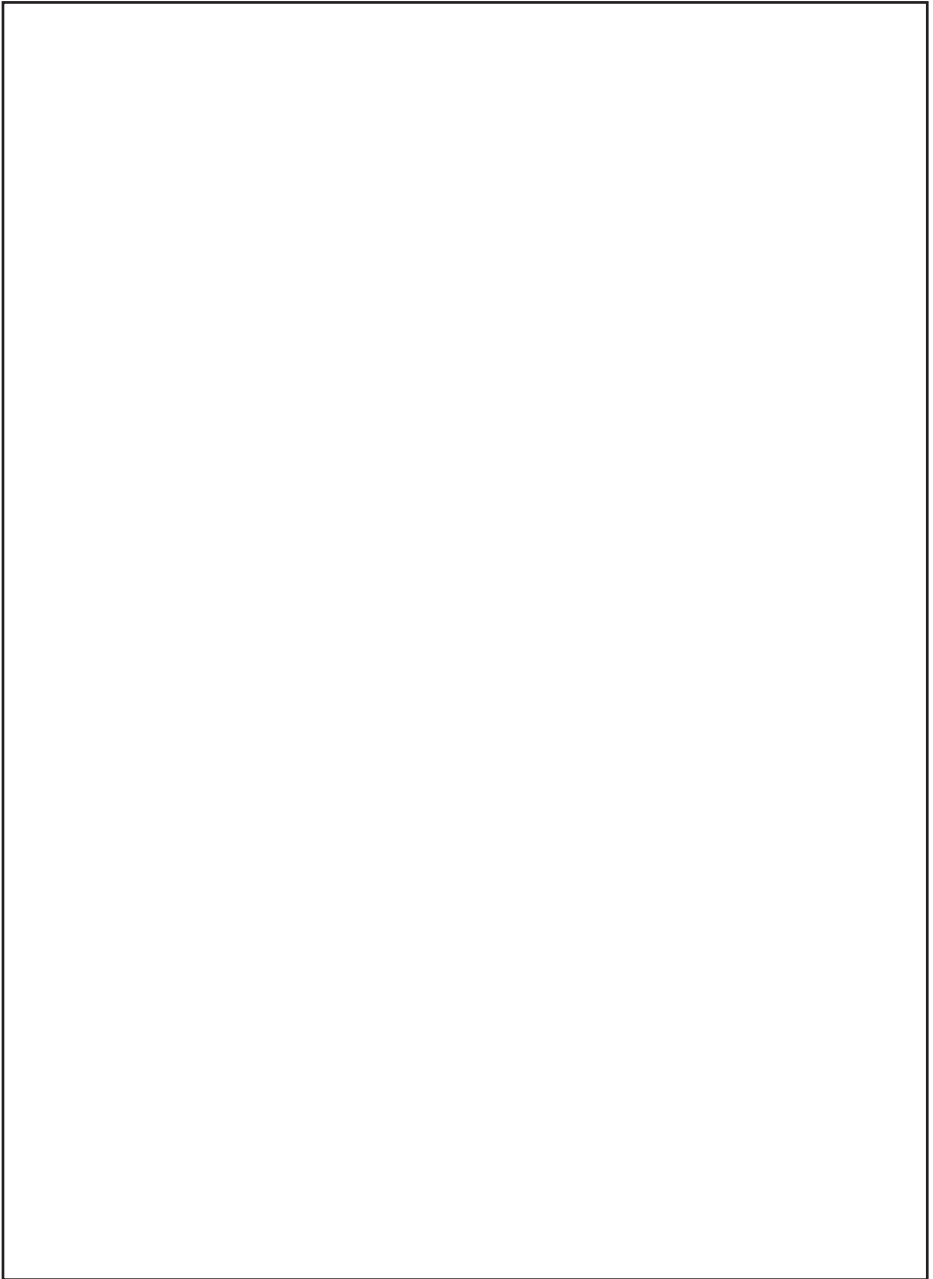

The logo features a stylized '@' symbol in green, followed by the word 'Lumen8' in a bold, black, sans-serif font. Below the text are three horizontal bars: a red bar under 'L', a green bar under 'u', and a blue bar under 'e'.
www.prolight.co.uk