

elumen8

Virtuoso 600 Profile WW User Manual



Order code: ELUM136

WARNING

FOR YOUR OWN SAFETY, PLEASE READ THIS USER MANUAL CAREFULLY BEFORE YOUR INITIAL START-UP!

- Before your initial start-up, please make sure that there is no damage caused during transportation.
- Should there be any damage, consult your dealer and do not use the equipment.
- To maintain the equipment in good working condition and to ensure safe operation, it is necessary for the user to follow the safety instructions and warning notes written in this manual.
- Please note that damages caused by user modifications to this equipment are not subject to warranty.



IMPORTANT:

The manufacturer will not accept liability for any resulting damages caused by the non-observance of this manual or any unauthorised modification to the equipment.

- Never let the power cable come into contact with other cables. Handle the power cable and all mains voltage connections with particular caution!
- Never remove warning or informative labels from the unit.
- Do not open the equipment and do not modify the unit.
- Do not connect this equipment to a dimmer pack.
- Do not switch the equipment on and off in short intervals, as this will reduce the system's life.
- Only use the equipment indoors.
- Do not expose to flammable sources, liquids or gases.
- Always disconnect the power from the mains when equipment is not in use or before cleaning! Only handle the power-cable by the plug. Never pull out the plug by pulling the power-cable.
- Make sure that the available mains supply voltage is between 100~240V AC, 50/60Hz.
- Make sure that the power cable is never crimped or damaged. Check the equipment and the power cable periodically.
- If the equipment has been exposed to drastic temperature fluctuation (e.g. after transportation), do not connect power or switch it on immediately. The arising condensation might damage the equipment. Leave the equipment switched off until it has reached room temperature.
- Never touch the fixture during operation as it may be hot.
- If the equipment is dropped or damaged, disconnect the mains power supply immediately and have a qualified engineer inspect the equipment before operating again.
- If your product fails to function correctly, stop use immediately. Pack the unit securely (preferably in the original packing material), and return it to your Pro Light dealer for service.
- Only use fuses of same type and rating.
- Repairs, servicing and power connection must only be carried out by a qualified technician. THIS UNIT CONTAINS NO USER SERVICEABLE PARTS.
- This lighting fixture is for professional use only - it is not designed for or suitable for household use. The product must be installed by a qualified technician in accordance with local territory regulations. The safety of the installation is the responsibility of the installer. The fixture presents risks of severe injury or death due to fire hazards, electric shock and falls.
- Warning! Risk Group 2 LED product according to EN 62471. Do not view the light output with optical instruments or any device that may concentrate the beam.
- WARRANTY: Two years from date of purchase.

OPERATING DETERMINATIONS

If this equipment is operated in any other way, than those described in this manual, the product may suffer damage and the warranty becomes void. Incorrect operation may lead to danger e.g: short-circuit, burns and electric shocks etc.

Do not endanger your own safety and the safety of others!

Incorrect installation or use can cause serious damage to people and/or property.

Please note: These fixtures are intended for stage lighting and entertainment applications only, and are not intended for extended periods of use, including but not limited to house-light, industrial or architectural applications and should only be operated with short duty cycles.

Virtuoso 600 Profile WW

The Virtuoso 600 is a compact Profile that features an advanced WW LED system which excels in delivering super smooth dimming and is suitable for many applications. Focus the fixture without DMX signal at the push of a button thanks to the 'instant focus' mode. On board features include DMX, RDM and adjustable PWM rate. The fixture is enclosed in a compact, robust chassis and features four framing shutters plus an M size gobo slot further expanding the versatility of this fixture.

- 2 year warranty
- 1 x 150W warm-white LED (3200K)
- Manually adjustable beam angle: 25° - 50°
- 25° - 17,650 Lux @ 2m, 50° - 5,137 Lux @ 2m
- CRI: 98
- Refresh rate: 1.2kHz, 2.4kHz, 4kHz, 6kHz or 25kHz selectable
- Beam framing shutters
- M size gobo slot
- DMX channels: 1/2 or 4 selectable
- RDM (Remote Device Management)
- Dimmer pack control
- Manual and master/slave modes
- 0 - 100% 8 or 16 bit dimming
- Variable strobe
- 4 push button menu with LCD display
- PowerTwist TR1 input/output
- 5-Pin XLR input/output
- 3 selectable fan modes (live, power and studio)
- Instant fast focus mode



Specifications	Virtuoso 600 Profile WW
Power consumption	172W
Power supply	100~240V, 50/60Hz (voltage selector switch)
Fuse	T3.15A 250V
Dimensions	370 x 220 x 480mm
Weight	6.1kg
Order code	ELUM136

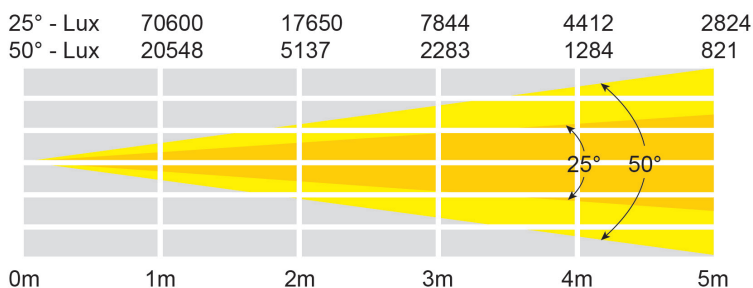

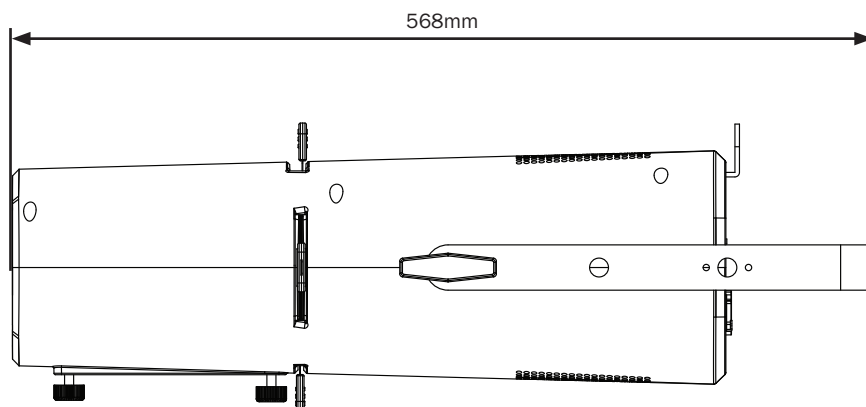
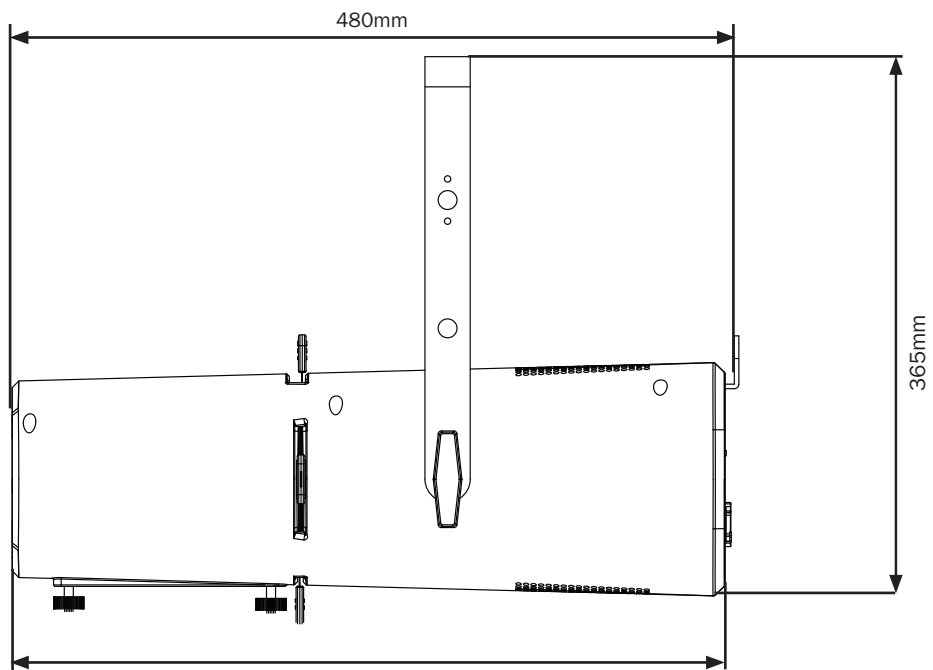
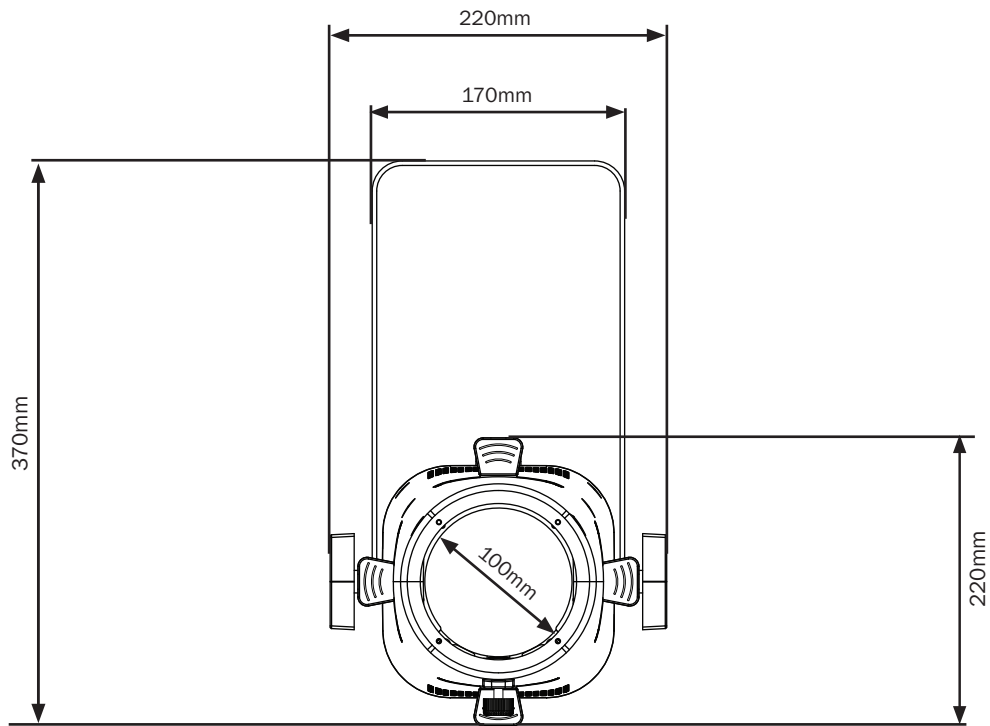

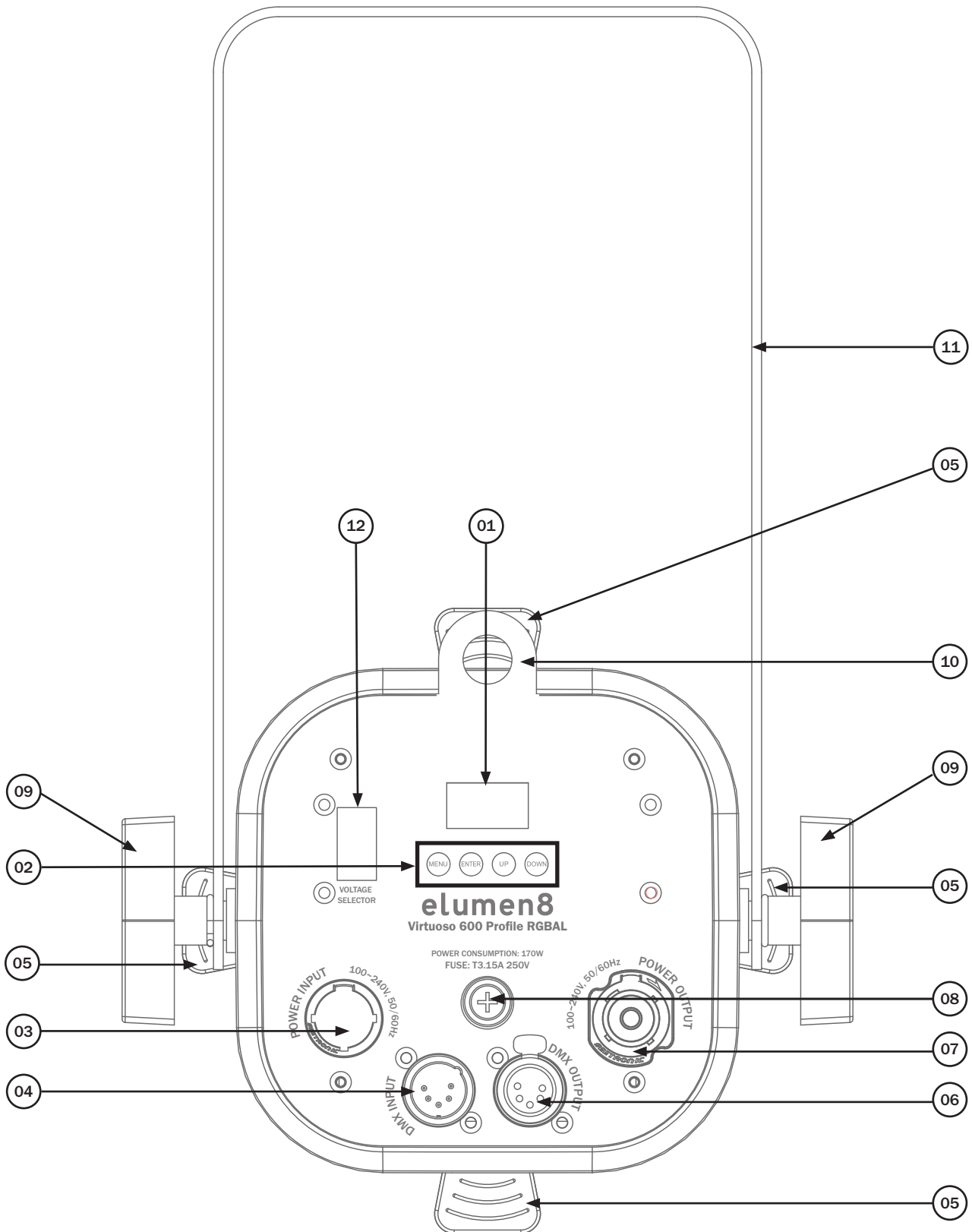

- 01 - LCD display
- 02 - Function buttons
- 03 - PowerTwist TR1 input
- 04 - 5-Pin DMX input
- 05 - Beam framing shutters

- 06 - 5-Pin DMX output
- 07 - PowerTwist TR1 output
- 08 - Fuse T3.15A 250V
- 09 - Hanging bracket adjustment knobs

- 10 - Safety eye
- 11 - Hanging bracket
- 12 - Voltage selector switch

In the box: **1 x fixture,**
1 x safety wire &
1 x power cable

Before installing the fixture, the supporting structure (ie. truss) must be able to hold a minimum of 10 times the fixtures weight without any deformation (eg. 15kg - 150kg point load). The fixture must be secured with a secondary safety attachment when being installed (ie. an appropriate safety cable). Never stand directly below the fixture when mounting, removing, and/or servicing.

Overhead installation requires experience and qualifications to calculate working load limits, the material being used at the installation area and periodic safety inspections of the fixture and installation material. If you do not have the relevant experience and/or qualifications please do not attempt the installation yourself. The installation should be checked annually by a qualified person.

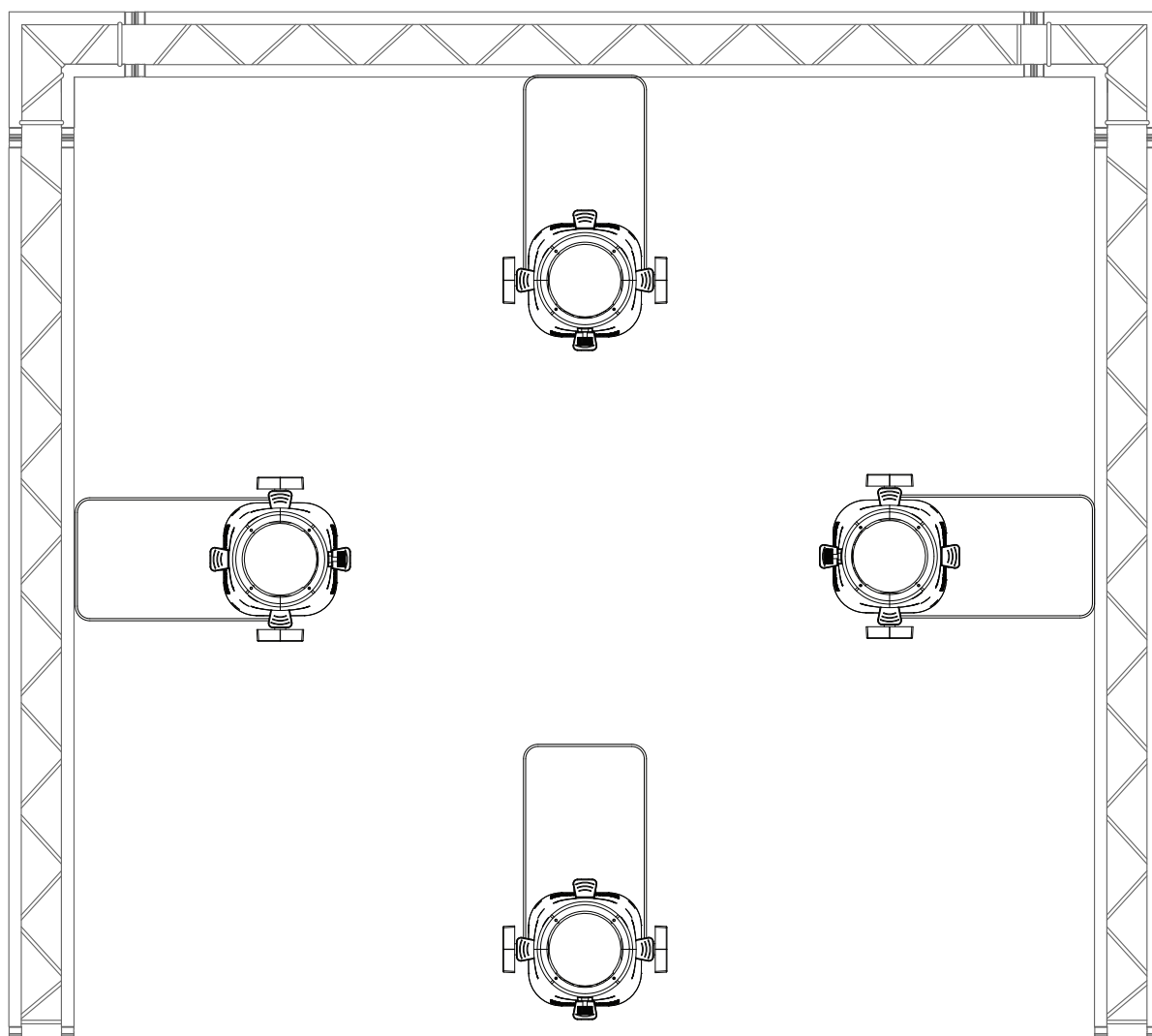

The Elumen8 Virtuoso 600 Profile WW can be operated in a number of mounting positions as shown in the diagram above, hanging upside-down from the ceiling or truss, mounting sideways on truss or stood upright on a flat level surface. Always use a safety wire as an extra safety precaution to prevent damage/injury in the event a clamp fails (see the next page for clamp installation).

Never use the carry handles for secondary attachments.

Installation:

1. Fasten the clamp to the fixtures bracket with a bolt and lock nut through one of the mounting holes.
2. Mount the fixture onto your truss system via the clamp and tighten to ensure secure.
3. Pull the safety cable through the fixture bracket and around the truss.

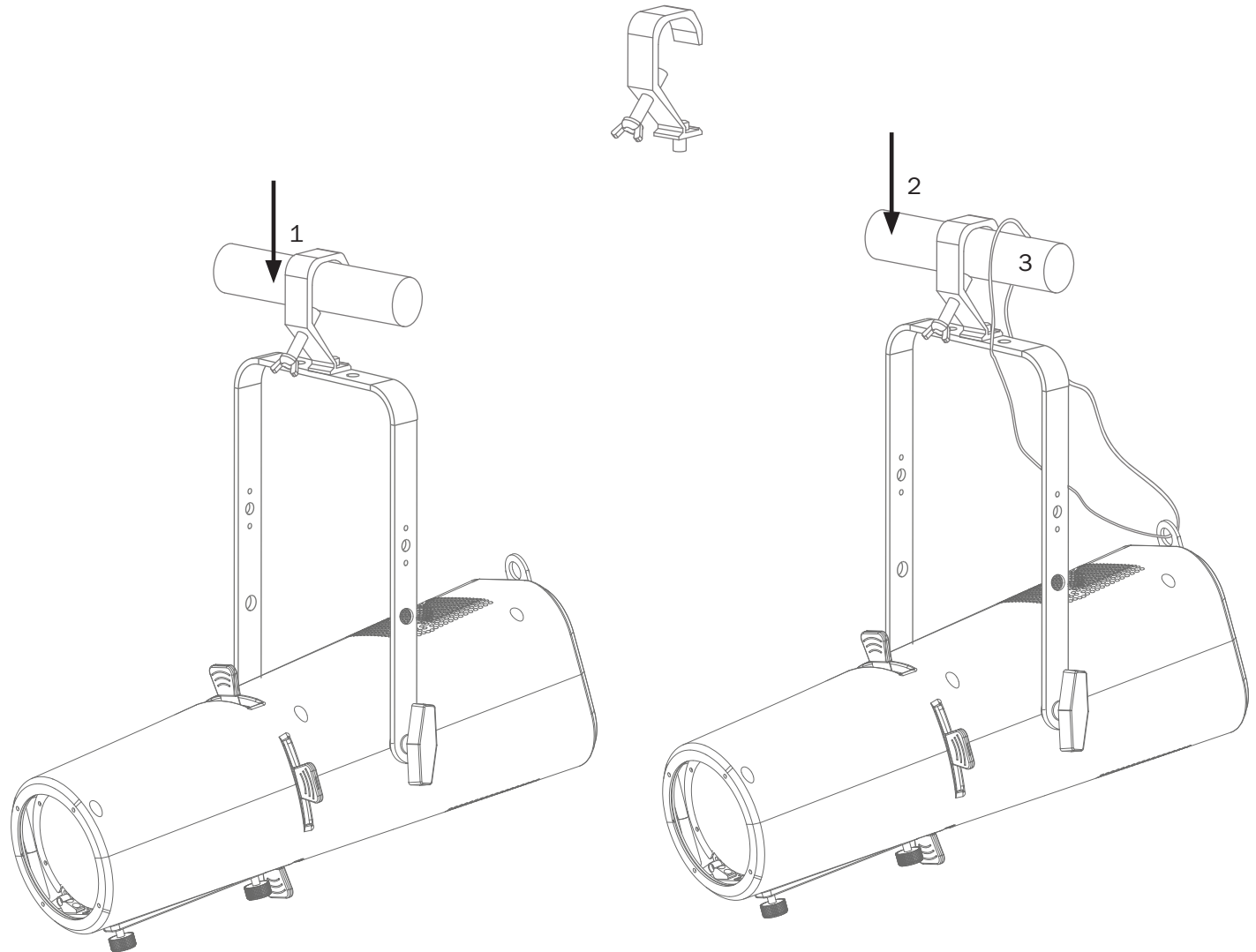

Beam Focus:

1. Loosen the beam focus knobs located at the bottom of the barrel.
2. Slide the lens tube forward or backward until you achieve the desired focus.
3. Once the fixture is focussed, tighten the beam focus knobs.

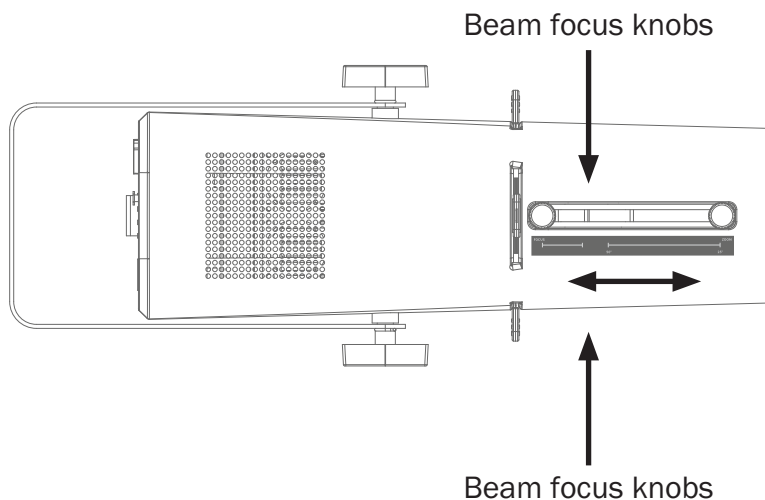

Shutters:

The shutters are located inside the barrel. They can be adjusted via the shutter handles to adjust the shape of the beam.

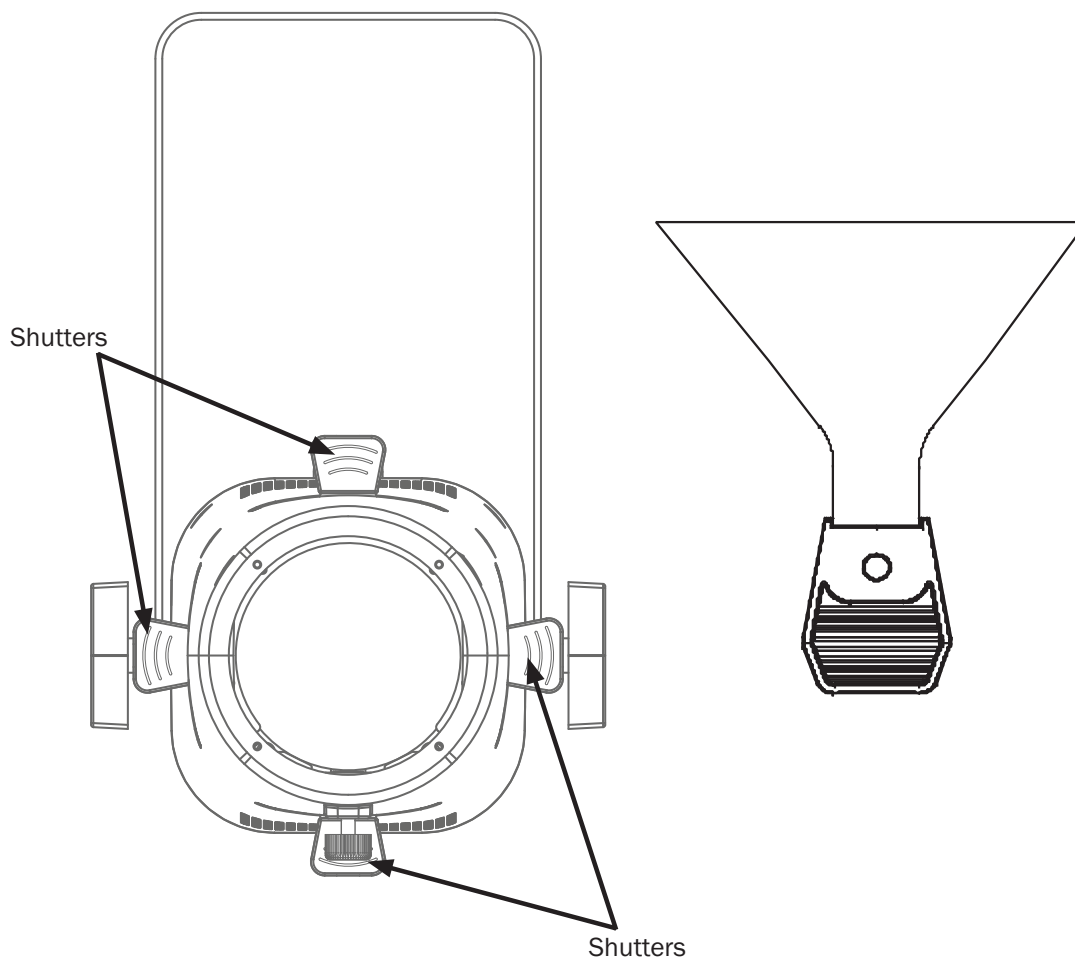

Main Menu	Sub Menus	Values (Default Settings in BOLD)	Description		
STATIC	WHITE	0-255	Manual mode		
	STROBE	0-25			
ADDRESS		001 -512	DMX address settings		
RUN MODE	DMX		DMX mode		
	Slave		Master/slave mode		
	DMMR		Dimmer pack control mode		
	SENS		Auto detect DMX/DMMR mode		
PERSONALITY	UNO (1 channel)		DMX channel mode settings		
	DOS (2 channel)				
	STD.P (4 channel)				
SETTING	PASSCODE (<UP> <DOWN> <UP> <DOWN> <ENTER>)	RESET	PASSCODE (<UP>, <DOWN>, <UP>, <DOWN>, <ENTER>)	Restore factory settings	
		DIMMER	DIM4	Dimmer settings	
			DIM3		
			DIM2		
			DIM1		
			OFF		
		DMX ERROR	SAVE	DMX fail settings	
			BLACK		
		PWM RATE	1200HZ	Refresh rate settings	
			2400HZ		
			4000HZ		
			6000HZ		
			25000HZ		
		PERFORM	LIVE (low)	Fan speed settings	
			POWER (high)		
			STUDIO (auto)		
		DISP KEY	ON	Display lock setting (passcode is <UP>, <DOWN>, <UP>, <DOWN>, <ENTER>)	
			OFF		
		DISP TIME	ON	Display backlight settings	
			10S		
30S					
2MIN					
INFO	FIXTURE HOURS		xxh	Fixture hours	
	VERSION		VXXXXXXXXX	Software version	
	RDM	UID		0X09a5XXXXXXXX	Fixture UID
		LABEL		Virtuoso 600 Profile WW	Fixture model

DMX channel modes:

UNO (1 channel mode)

Channel	Value	Function
CH1	000-255	Master dimmer (0-100%)

DOS (2 channel mode)

Channel	Value	Function
CH1	000-255	Master dimmer (0-100%)
CH2	000-255	Dimmer fine (0-100%)

STD.P (4 channel mode)

Channel	Value	Function
CH1	000-255	Master dimmer (0-100%)
CH2	000-255	Dimmer fine (0-100%)
CH3	Strobe	
	000-009	No function
	010-099	Strobe (slow-fast)
	100-109	No function
	110-179	Lightning strobe
	180-189	No function
	190-255	Random strobe
CH4	Control	
	000-060	No function
	061-070	Live
	071-080	Studio
	081-090	Power
	091-100	No function
	101-110	Dimmer off
	111-120	Dimmer Dim4
	121-150	No function
	151-160	1200Hz
	161-170	2400Hz
	171-180	4000Hz
	181-190	6000Hz
	191-200	25000Hz
201-210	All reset	
211-255	No function	

PLEASE NOTE:

Please ensure the voltage selector switch is set to the correct voltage for your country.

Instant fast focus mode:

If you need to focus the fixture quickly and easily when nobody is around to control via DMX you can put the fixture into “Instant fast focus mode”. To do this hold down the “MENU” button for 5 seconds and the fixture will come on at full brightness for 60 seconds, which will allow you to set the focus. After 60 seconds the fixture will return to normal operation.

Setting the DMX address:

The DMX mode enables the use of a universal DMX controller. Each fixture requires a “start address” from 1- 512. A fixture requiring one or more channels for control begins to read the data on the channel indicated by the start address. For example, a fixture that occupies or uses 7 channels of DMX and was addressed to start on DMX channel 100, would read data from channels: 100, 101, 102, 103, 104, 105 and 106. Choose a start address so that the channels used do not overlap. E.g. the next unit in the chain starts at 107.

DMX 512:

DMX (Digital Multiplex) is a universal protocol used as a form of communication between intelligent fixtures and controllers. A DMX controller sends DMX data instructions from the controller to the fixture. DMX data is sent as serial data that travels from fixture to fixture via the DATA “IN” and DATA “OUT” XLR terminals located on all DMX fixtures (most controllers only have a data “out” terminal).

DMX linking:

DMX is a language allowing all makes and models of different manufactures to be linked together and operate from a single controller, as long as all fixtures and the controller are DMX compliant. To ensure proper DMX data transmission, when using several DMX fixtures try to use the shortest cable path possible. The order in which fixtures are connected in a DMX line does not influence the DMX addressing. For example; a fixture assigned to a DMX address of 1 may be placed anywhere in a DMX line, at the beginning, at the end, or anywhere in the middle. When a fixture is assigned a DMX address of 1, the DMX controller knows to send DATA assigned to address 1 to that unit, no matter where it is located in the DMX chain.

DATA cable (DMX cable) requirements (for DMX operation):

This fixture can be controlled via DMX-512 protocol. The DMX address is set on the back of the unit. Your unit requires either a standard 3-pin or 5-pin XLR connector for data input/output, see images below.



Further DMX cables can be purchased from all good sound and lighting suppliers or Prolight Concepts dealers.

Please quote:	3-Pin:	CABL10 – 2m	CABL11 – 5m	CABL12 – 10m
	5-Pin:	CABL185 – 2m	CABL187 – 5m	CABL188 – 10m

Also remember that DMX cable must be daisy chained and cannot be split.

Notice:

Be sure to follow the diagrams below when making your own cables. Do not connect the cables shield conductor to the ground lug or allow the shield conductor to come in contact with the XLRs outer casing. Grounding the shield could cause a short circuit and erratic behaviour.

Pin Configuration	
3-Pin	5-Pin
	Pin 1 - Ground
	Pin 2 - Negative
	Pin 3 - Positive
-	Pin 4 - N/C
-	Pin 5 - N/C

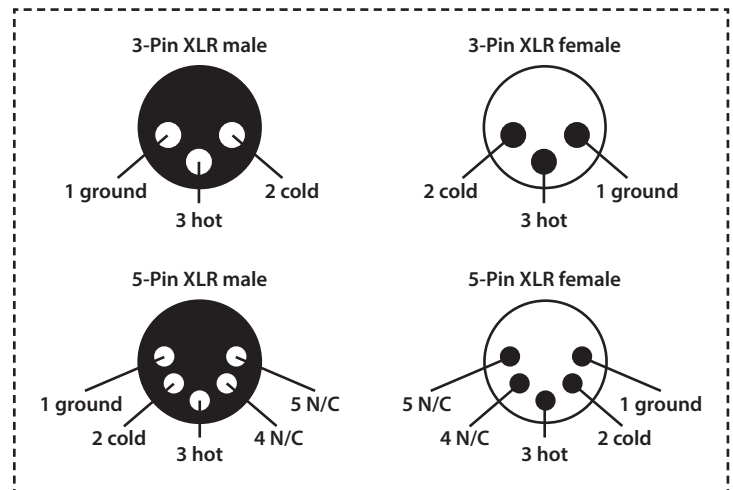
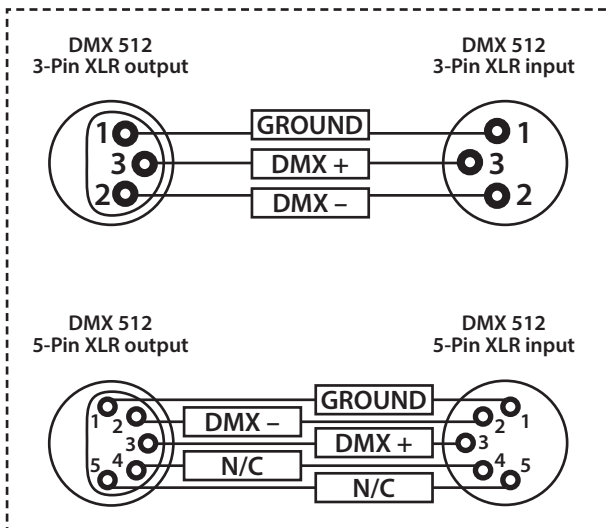

Line termination:

When longer runs of cable are used, you may need to use a terminator on the last unit to avoid erratic behaviour.

Using a cable terminator will decrease the possibilities of erratic behaviour.

(3-pin - Order ref: CABL90,
5-pin - Order ref: CABL89)

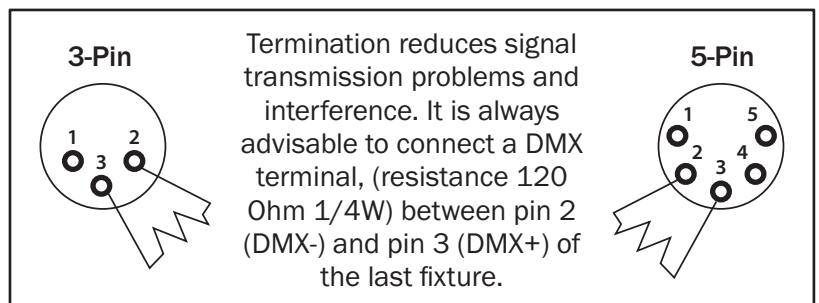

5-pin XLR DMX connectors:

Some manufactures use 5-pin XLR connectors for data transmission in place of 3-pin. 5-pin XLR fixtures may be implemented in a 3-pin XLR DMX line. When inserting standard 5-pin XLR connectors in to a 3-pin line a cable adaptor must be used. The diagram below details the correct cable conversion.

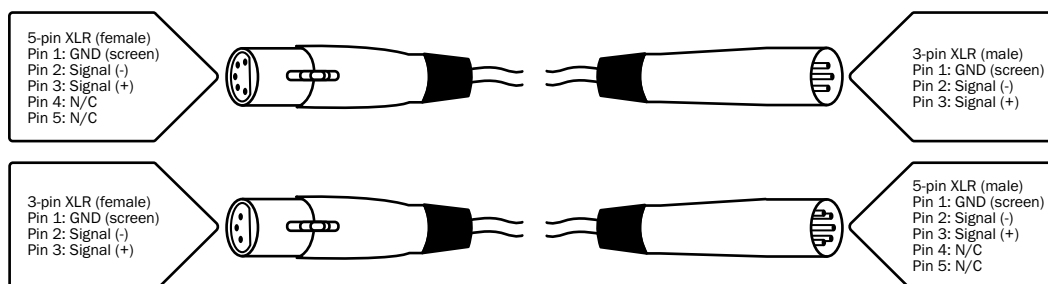

Power linking:

This fixture provides power linking via the power output on the rear allowing multiple units to be connected together. The maximum number of fixtures that can be connected is 8 fixtures @ 240V or 4 fixtures @ 120V (including the first fixture). After the maximum number of fixtures are connected a new power run will need to be started.

Please note: Caution should be used when power linking other fixtures to the Virtuoso 600 Profile as the power consumption of other fixtures will vary. Fixtures fitted with lamps often require 2/3 times more current on startup, these may require their own power source.

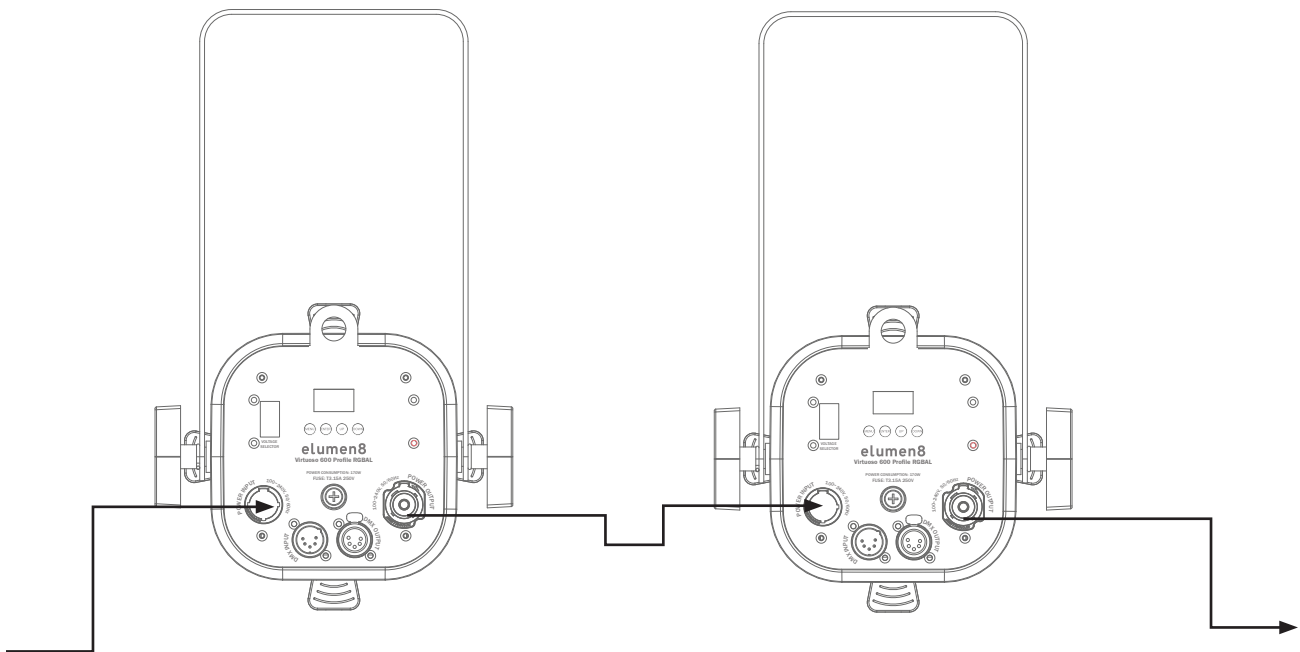



***Correct Disposal of this Product
(Waste Electrical & Electronic Equipment)***

**(Applicable in the European Union and other European countries
with separate collection systems)**

This marking shown on the product or its literature, indicates that it should not be disposed with other household wastes at the end of its working life. To prevent possible harm to the environment or human health from uncontrolled waste disposal, please separate this from other types of wastes and recycle it responsibly to promote the sustainable reuse of material resources.

Household users should contact either the retailer where they purchased this product, or their local government office, for details of where and how they can take this item for environmentally safe recycling.

Business users should contact their supplier and check the terms and conditions of the purchase contract. This product should not be mixed with other commercial wastes for disposal.

