

elumen8

Cygnus **SPLIT6 DMX Splitter** User Manual



Order codes: ELUM250

WARNING

FOR YOUR OWN SAFETY, PLEASE READ THIS USER MANUAL CAREFULLY BEFORE YOUR INITIAL START-UP!

- Before your initial start-up, please make sure that there is no damage caused during transportation.
- Should there be any damage, consult your dealer and do not use the equipment.
- To maintain the equipment in good working condition and to ensure safe operation, it is necessary for the user to follow the safety instructions and warning notes written in this manual.
- Please note that damages caused by user modifications to this equipment are not subject to warranty.



IMPORTANT:

The manufacturer will not accept liability for any resulting damages caused by the non-observance of this manual or any unauthorised modification to the equipment.

- Never let the power cable come into contact with other cables. Handle the power cable and all mains voltage connections with particular caution!
- Never remove warning or informative labels from the unit.
- Do not open the equipment and do not modify the unit.
- Do not switch the equipment on and off in short intervals, as this will reduce the system's life.
- Only use the equipment indoors.
- Do not expose to flammable sources, liquids or gases.
- Always disconnect the power from the mains when equipment is not in use or before cleaning! Only handle the power-cable by the plug. Never pull out the plug by pulling the power-cable.
- Make sure that the available mains supply voltage is 100~240V, 50/60Hz.
- Make sure that the power cable is never crimped or damaged. Check the equipment and the power cable periodically.
- If the equipment is dropped or damaged, disconnect the mains power supply immediately and have a qualified engineer inspect the equipment before operating again.
- If the equipment has been exposed to drastic temperature fluctuation (e.g. after transportation), do not connect power or switch it on immediately. The arising condensation might damage the equipment. Leave the equipment switched off until it has reached room temperature.
- If your product fails to function correctly, stop use immediately. Pack the unit securely (preferably in the original packing material), and return it to your Pro Light dealer for service.
- Only use fuses of same type and rating.
- Repairs, servicing and power connection must only be carried out by a qualified technician. THIS UNIT CONTAINS NO USER SERVICEABLE PARTS.
- This fixture is for professional use only - it is not designed for or suitable for household use. The product must be installed by a qualified technician in accordance with local territory regulations. The safety of the installation is the responsibility of the installer. The fixture presents risks of severe injury or death due to fire hazards, electric shock and falls.
- WARRANTY: Two years from date of purchase.

OPERATING DETERMINATIONS

If this equipment is operated in any other way, than those described in this manual, the product may suffer damage and the warranty becomes void. Incorrect operation may lead to danger e.g: short-circuit, burns and electric shocks etc.

Do not endanger your own safety and the safety of others!

Incorrect installation or use can cause serious damage to people and/or property.

Cygnus SPLIT6 DMX Splitter

The Elumen8 Cygnus Series is a comprehensive range of advanced data-management solutions engineered to meet the demands of modern lighting networks. Designed with professional users in mind, the series includes DMX splitters, DMX mergers, Art-Net nodes, and sleek wall-plate interfaces, each crafted to simplify complex system layouts while maximising control efficiency. Whether you're expanding a theatre's infrastructure, integrating robust data routing for live production, or building a permanent architectural installation, Cygnus delivers.



The SPLIT6 is a 6-way DMX distribution splitter/booster featuring one input, passthrough with switchable termination facility and 6 outputs electronically opto isolated from each other and from the input.

The SPLIT6 can be used to simplify DMX cabling allowing lighting systems to be cabled in a star format while working to prevent data errors. Each of the six outputs features an independent driver coupled with DMX indicator LEDs. All DMX inputs and outputs are equipped with both 3-Pin and 5-Pin XLR Seetronic connectors.

Housed within a rugged 1U, 19" rack mount chassis the SPLIT6 has an M10 mounting point for clamps and is ideally suited to professional applications, ensuring your show data arrives exactly where it needs to, every time.

- 1 x Seetronic DMX input (3-Pin or 5-Pin)
- 1 x Seetronic passthrough (3-Pin or 5-Pin)
- 6 x Seetronic DMX outputs (3-Pin or 5-Pin)
- Boosts DMX signal
- Outputs electronically opto isolated from each other and from the input
- Link output with switchable termination facility
- Power and DMX indicator LEDs
- M10 rigging point for clamp
- Powder coated, aluminium, 1U, 19" rack mount chassis
- Power Twist TR1 input/output
- Convection cooled

Specifications	Cygnus SPLIT6 DMX Splitter
Power supply	100~240V, 50/60Hz
Fuse	T1A 250V
Dimensions (H x W x D)	45 x 485 x 150mm
Weight	1.9kg
Order code	ELUM250

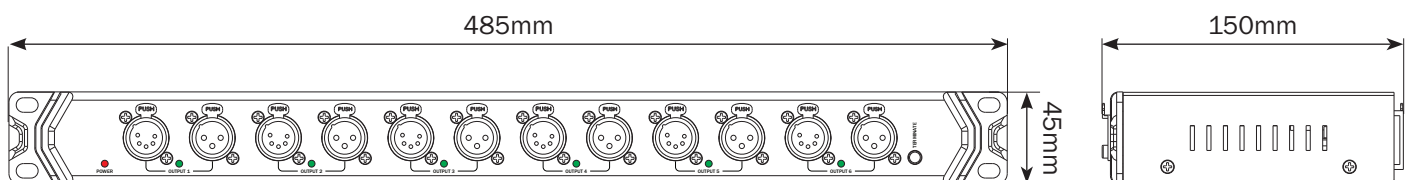

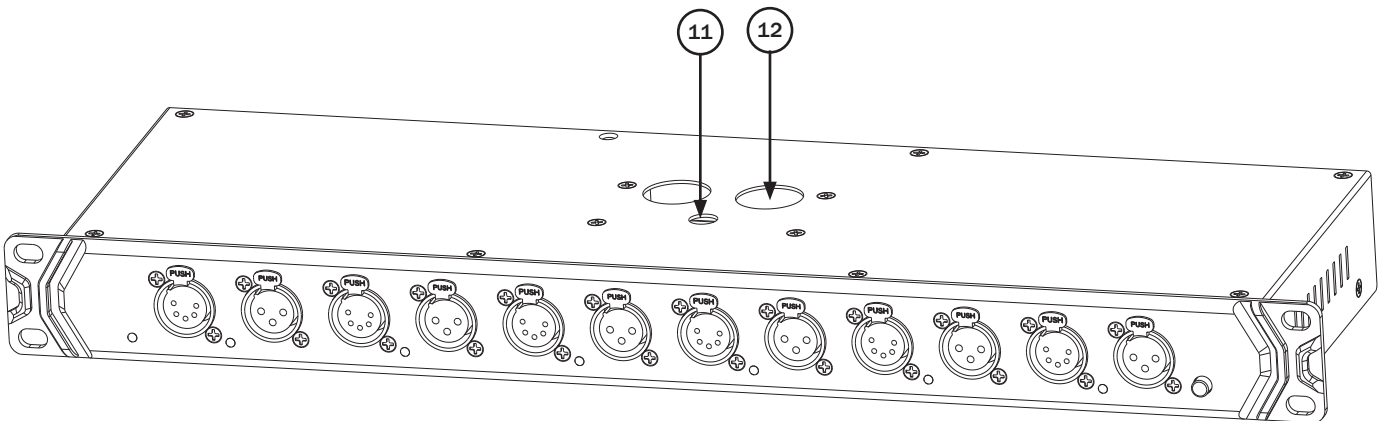
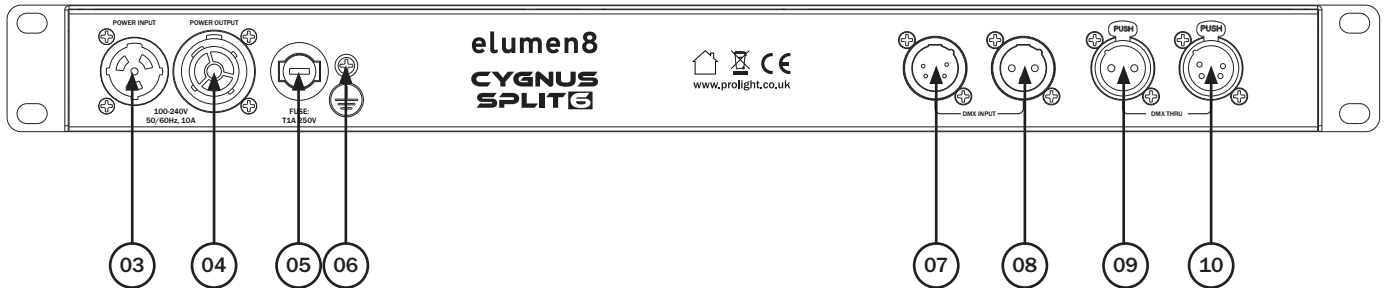
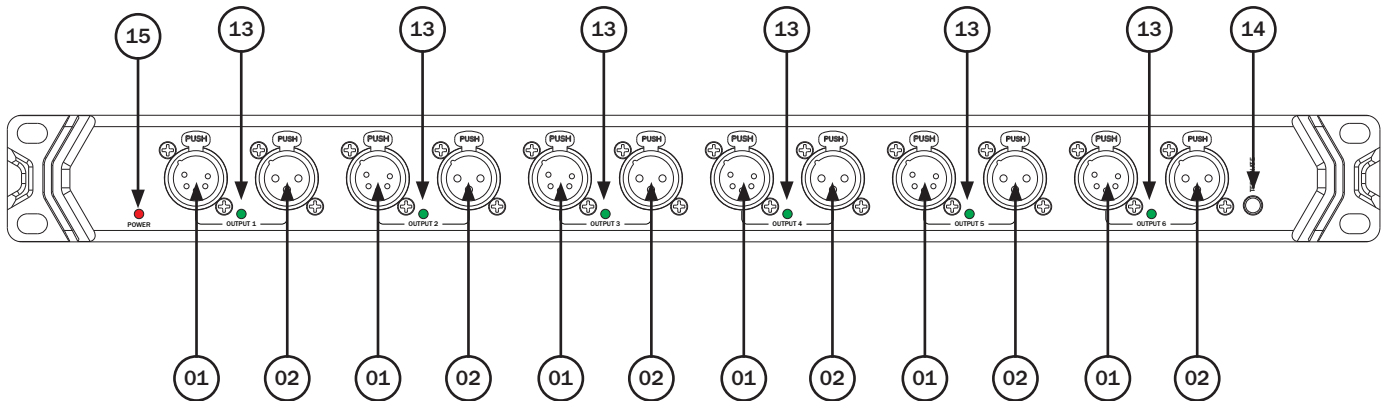

- 01 - 5-Pin Seetronic DMX outputs
- 02 - 3-Pin Seetronic DMX outputs
- 03 - Power Twist TR1 input
- 04 - Power Twist TR1 output
- 05 - Fuse T1A 250V
- 06 - Earth point
- 07 - 5-Pin Seetronic DMX input
- 08 - 3-Pin Seetronic DMX input

- 09 - 3-Pin Seetronic DMX link output
- 10 - 5-Pin Seetronic DMX link output
- 11 - M10 mounting point
- 12 - Safety eye
- 13 - DMX signal indicators
- 14 - Termination switch
- 15 - Power Indicator

In the box:
1 x SPLIT6,
1 x power cable

Installation:

1. Pull the safety wire through the safety cable holes located on the top of the fixture.
2. Insert the clamp into the corresponding holes on the top of the unit, ensuring it's fully secure.
3. Mount the fixture onto your truss system via the clamp and tighten to ensure secure.
4. Pull the safety wire around the truss.

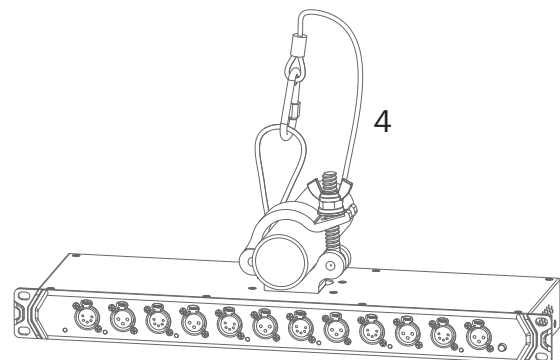
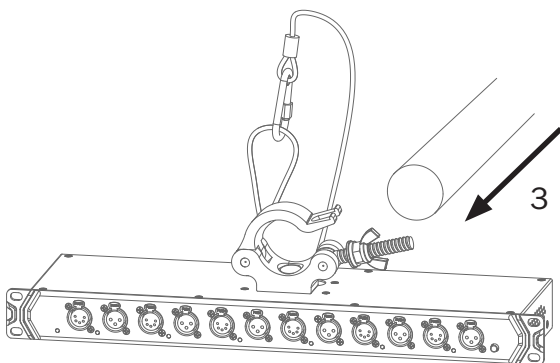
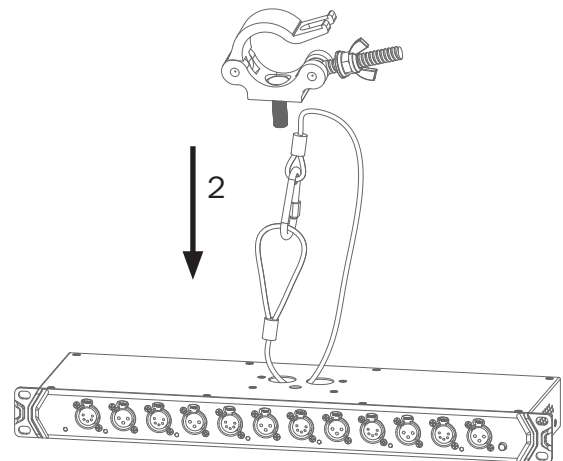
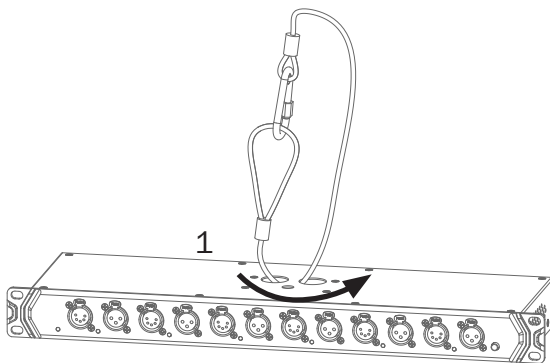

Installation:

1. Insert the unit into the rack and align the mounting holes with the rack rails.
2. Secure the unit to the rack using mounting screws.

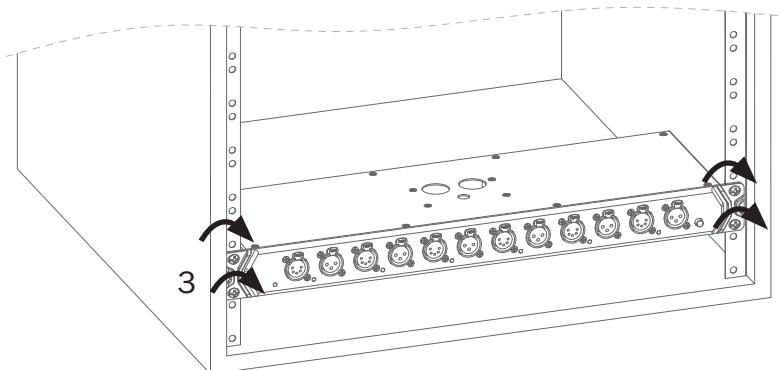
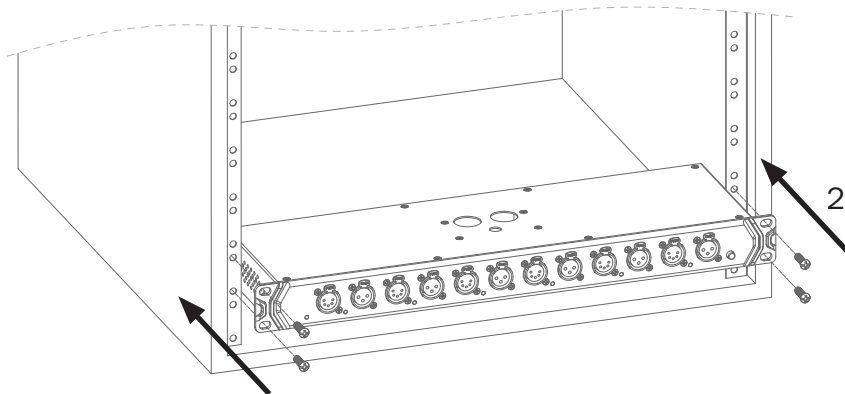
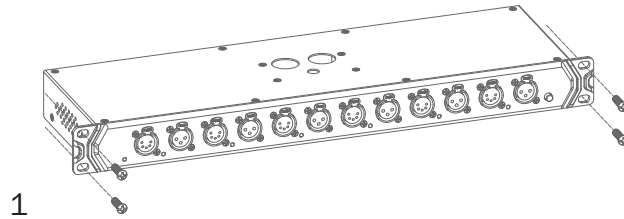

Setup:

Connect a DMX signal cable from a lighting controller into the DMX input on the Cygnus SPLIT6 either via the 3-Pin or 5-Pin input on the rear panel. The SPLIT6 has 6 outputs each with both 3-Pin and 5-Pin XLR connectors, only one of the two connectors can be used per DMX output at once.

From each DMX output a DMX signal cable may be connected with up to 32 fixtures per signal line, and up to 100m distance of total cable length.

Once the lighting controller and fixtures are connected to the SPLIT6, power the device via the Seetronic Power Twist TR1 power input on the rear panel.

LED indicators:

The Cygnus SPLIT6 is fitted with a number of LED indicators, their functions are detailed below.

POWER – The power indicator located on the left of the front panel will illuminate red to indicate the unit is receiving power.

SIGNAL – The signal indicators located under each output on the front panel will illuminate green to indicate presence of a DMX signal into the SPLIT6. If there is a problem with one of the outputs the LED will not be illuminated.

Link out:

The Cygnus SPLIT6 has a link output facility located on the rear panel. When the link output facility is not used, the terminate button on the front panel should be activated to terminate the DMX input signal.

Example connection diagrams:

Note: Please link all cables before connecting power.

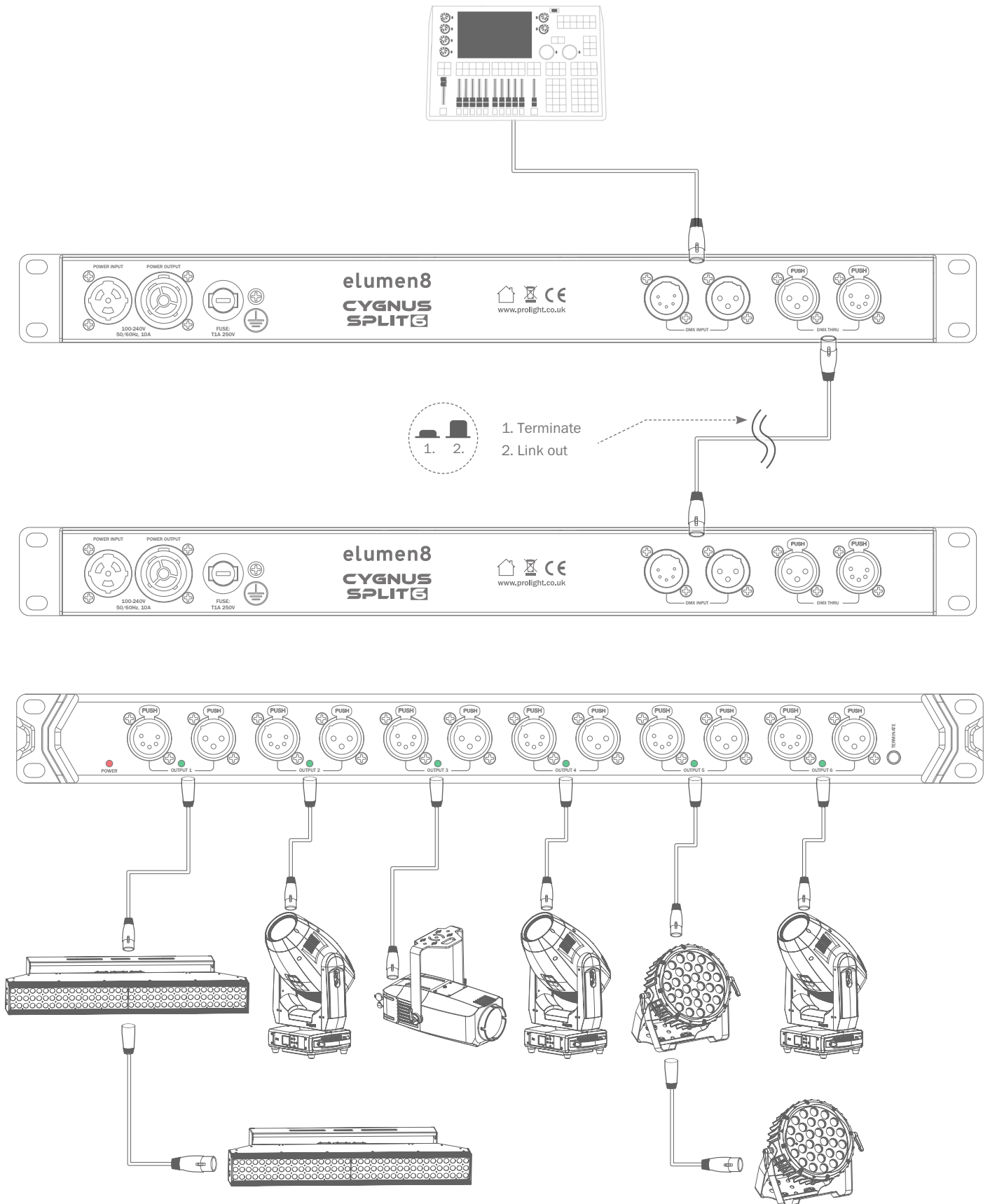

Setting the DMX address:

The DMX mode enables the use of a universal DMX controller. Each fixture requires a “start address” from 1- 512. A fixture requiring one or more channels for control begins to read the data on the channel indicated by the start address. For example, a fixture that occupies or uses 7 channels of DMX and was addressed to start on DMX channel 100, would read data from channels: 100, 101, 102, 103, 104, 105 and 106. Choose a start address so that the channels used do not overlap. E.g. the next unit in the chain starts at 107.

DMX 512:

DMX (Digital Multiplex) is a universal protocol used as a form of communication between intelligent fixtures and controllers. A DMX controller sends DMX data instructions from the controller to the fixture. DMX data is sent as serial data that travels from fixture to fixture via the DATA “IN” and DATA “OUT” XLR terminals located on all DMX fixtures (most controllers only have a data “out” terminal).

DMX linking:

DMX is a language allowing all makes and models of different manufacturers to be linked together and operate from a single controller, as long as all fixtures and the controller are DMX compliant. To ensure proper DMX data transmission, when using several DMX fixtures try to use the shortest cable path possible. The order in which fixtures are connected in a DMX line does not influence the DMX addressing. For example; a fixture assigned to a DMX address of 1 may be placed anywhere in a DMX line, at the beginning, at the end, or anywhere in the middle. When a fixture is assigned a DMX address of 1, the DMX controller knows to send DATA assigned to address 1 to that unit, no matter where it is located in the DMX chain.

DATA cable (DMX cable) requirements (for DMX operation):

This fixture can be controlled via DMX-512 protocol. The DMX address is set on the back of the unit. Your unit requires either a standard 3-pin or 5-pin XLR connector for data input/output, see images below. Using audio XLR cables for DMX lighting is discouraged because it causes signal degradation, leading to flickering, erratic, or non-responsive lights. Audio cables have different impedance (<75 Ω) and higher capacitance, which cannot accurately transmit high-speed digital DMX data (110-120 Ω). While it may work for short, simple setups, it is unreliable for professional, long-distance, or complex lighting rigs. Ensure you use DMX XLR cables.



Further DMX cables can be purchased from all good sound and lighting suppliers or Prolight Concepts dealers.

Please quote:	3-Pin:	CABL10 – 2m	CABL11 – 5m	CABL12 – 10m
	5-Pin:	CABL185 – 2m	CABL187 – 5m	CABL188 – 10m

Also remember that DMX cable must be daisy chained and cannot be split.

Notice:

Be sure to follow the diagrams below when making your own cables. Do not connect the cables shield conductor to the ground lug or allow the shield conductor to come in contact with the XLRs outer casing. Grounding the shield could cause a short circuit and erratic behaviour.

Pin Configuration	
3-Pin	5-Pin
	Pin 1 - Ground
	Pin 2 - Negative
	Pin 3 - Positive
-	Pin 4 - N/C
-	Pin 5 - N/C

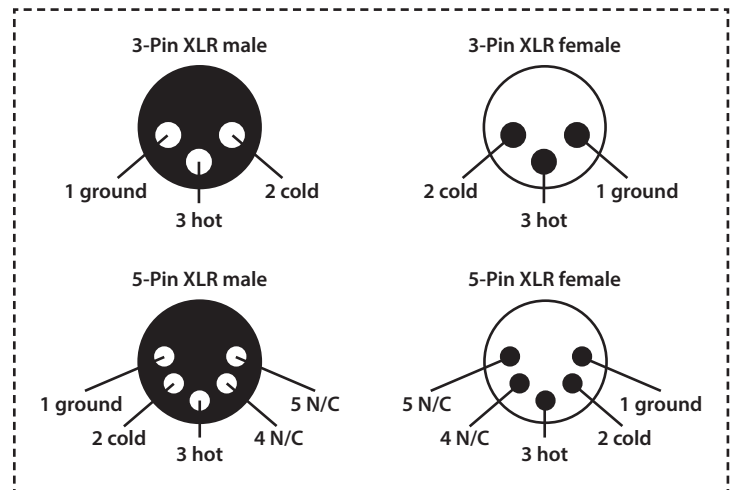
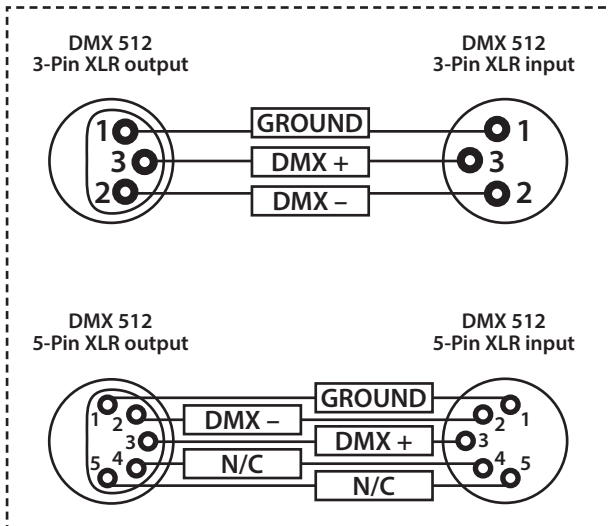

Line termination:

When longer runs of cable are used, you may need to use a terminator on the last unit to avoid erratic behaviour.

Using a cable terminator will decrease the possibilities of erratic behaviour.

(3-pin - Order ref: CABL90,
5-pin - Order ref: CABL89)

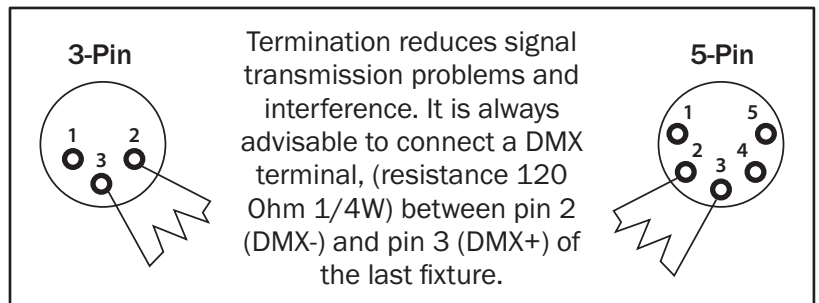

5-pin XLR DMX connectors:

Some manufacturers use 5-pin XLR connectors for data transmission in place of 3-pin. 5-pin XLR fixtures may be implemented in a 3-pin XLR DMX line. When inserting standard 5-pin XLR connectors in to a 3-pin line a cable adaptor must be used. The diagram below details the correct cable conversion.

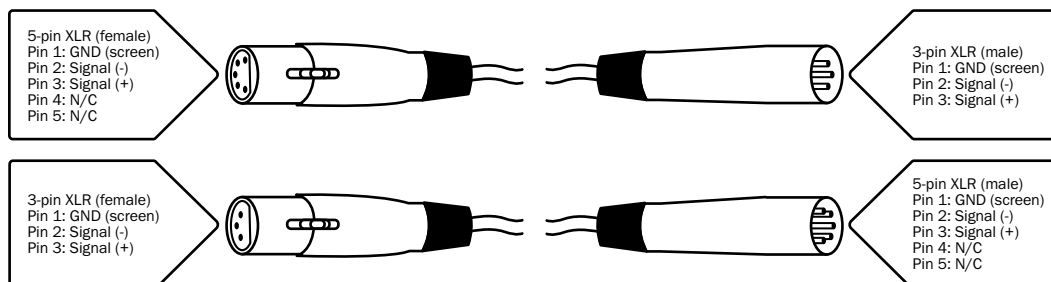



***Correct Disposal of this Product
(Waste Electrical & Electronic Equipment)***

**(Applicable in the European Union and other European countries
with separate collection systems)**

This marking shown on the product or its literature, indicates that it should not be disposed with other household wastes at the end of its working life. To prevent possible harm to the environment or human health from uncontrolled waste disposal, please separate this from other types of wastes and recycle it responsibly to promote the sustainable reuse of material resources.

Household users should contact either the retailer where they purchased this product, or their local government office, for details of where and how they can take this item for environmentally safe recycling.

Business users should contact their supplier and check the terms and conditions of the purchase contract. This product should not be mixed with other commercial wastes for disposal.

This notice does not imply a requirement for the product to be returned to the manufacturer or supplier, disposal should be carried out via appropriate authorised recycling facilities in accordance with local regulations.

