

elumen8

Cygnus NET8 User Manual



Order codes: ELUM251

WARNING

FOR YOUR OWN SAFETY, PLEASE READ THIS USER MANUAL CAREFULLY BEFORE YOUR INITIAL START-UP!

- Before your initial start-up, please make sure that there is no damage caused during transportation.
- Should there be any damage, consult your dealer and do not use the equipment.
- To maintain the equipment in good working condition and to ensure safe operation, it is necessary for the user to follow the safety instructions and warning notes written in this manual.
- Please note that damages caused by user modifications to this equipment are not subject to warranty.



IMPORTANT:

The manufacturer will not accept liability for any resulting damages caused by the non-observance of this manual or any unauthorised modification to the equipment.

- Never let the power cable come into contact with other cables. Handle the power cable and all mains voltage connections with particular caution!
- Never remove warning or informative labels from the unit.
- Do not open the equipment and do not modify the unit.
- Do not switch the equipment on and off in short intervals, as this will reduce the system's life.
- Only use the equipment indoors.
- Do not expose to flammable sources, liquids or gases.
- Always disconnect the power from the mains when equipment is not in use or before cleaning! Only handle the power-cable by the plug. Never pull out the plug by pulling the power-cable.
- Make sure that the available mains supply voltage is 240V AC, 50Hz.
- Make sure that the power cable is never crimped or damaged. Check the equipment and the power cable periodically.
- If the equipment is dropped or damaged, disconnect the mains power supply immediately and have a qualified engineer inspect the equipment before operating again.
- If the equipment has been exposed to drastic temperature fluctuation (e.g. after transportation), do not connect power or switch it on immediately. The arising condensation might damage the equipment. Leave the equipment switched off until it has reached room temperature.
- If your product fails to function correctly, stop use immediately. Pack the unit securely (preferably in the original packing material), and return it to your Pro Light dealer for service.
- Only use fuses of same type and rating.
- Repairs, servicing and power connection must only be carried out by a qualified technician. THIS UNIT CONTAINS NO USER SERVICEABLE PARTS.
- This fixture is for professional use only - it is not designed for or suitable for household use. The product must be installed by a qualified technician in accordance with local territory regulations. The safety of the installation is the responsibility of the installer. The fixture presents risks of severe injury or death due to fire hazards, electric shock and falls.
- WARRANTY: One year from date of purchase.

OPERATING DETERMINATIONS

If this equipment is operated in any other way, than those described in this manual, the product may suffer damage and the warranty becomes void. Incorrect operation may lead to danger e.g: short-circuit, burns and electric shocks etc.

Do not endanger your own safety and the safety of others!

Incorrect installation or use can cause serious damage to people and/or property.

Cygnus NET8

The Elumen8 Cygnus Series is a comprehensive range of advanced data-management solutions engineered to meet the demands of modern lighting networks. Designed with professional users in mind, the series includes DMX splitters, DMX mergers, Art-Net nodes, and sleek wall-plate interfaces, each crafted to simplify complex system layouts while maximising control efficiency. Whether you're expanding a theatre's infrastructure, integrating robust data routing for live production, or building a permanent architectural installation, Cygnus delivers.



The NET8 is an 8-way universe node which converts Art-Net or sACN to DMX giving a maximum of 4096 channels. Two Ethernet sockets are included with one POE allowing for a single cable to be used for both power and data input. Data speeds of up to 1 GB/s can be achieved whilst the built-in network switch allows the NET8 to be used as an ethernet repeater.

An easy-to-use GUI allows remote access via a computer or over a network, whilst the built-in intuitive menu means all settings can be changed from the unit also. All DMX inputs and outputs are equipped with 5-Pin XLR Seetronic connectors.

Housed within a rugged 1U, 19" rack mount chassis the NET8 has an M10 mounting point for clamps and is ideally suited to professional applications, ensuring your show data arrives exactly where it needs to, every time.

- 2 x Seetronic etherCON compatible ethernet sockets for input/link output
- POE (IEEE 802.3 Af) power option
- 10 MB/s, 100 MB/s or 1 GB/s network speed
- Built-in network switch allows the unit to be used as an ethernet repeater
- 8 x Seetronic 5-Pin DMX outputs
- Easy-to-use web browser GUI
- Outputs electronically opto isolated from each other and from the input
- DMX, power, activity and link indicator LEDs
- Protocols: Art-Net, sACN, DMX, RDM, TCP-IPv4
- RDM (Remote Device Management)
- Static or DHCP manual IP address selection
- 1.8" OLED display with rotary control
- M10 rigging point for clamp
- Powder coated, aluminium, 1U, 19" rack mount chassis
- Power Twist TR1 input/output
- Convection cooled

Specifications	Cygnus NET8
Power supply	100~240V, 50/60Hz
Fuse	T1A 250V
Dimensions (H x W x D)	45 x 485 x 154mm
Weight	1.9kg
Order code	ELUM251

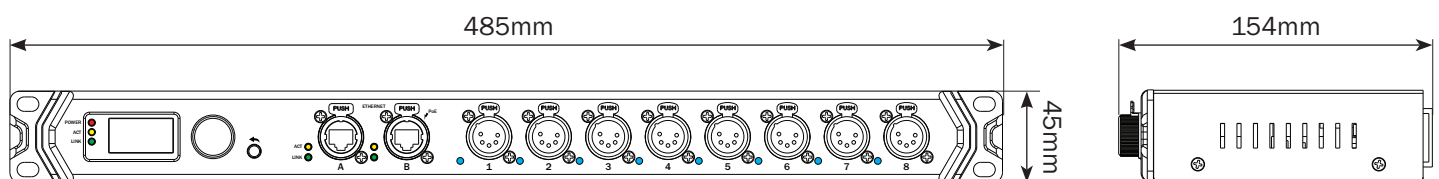

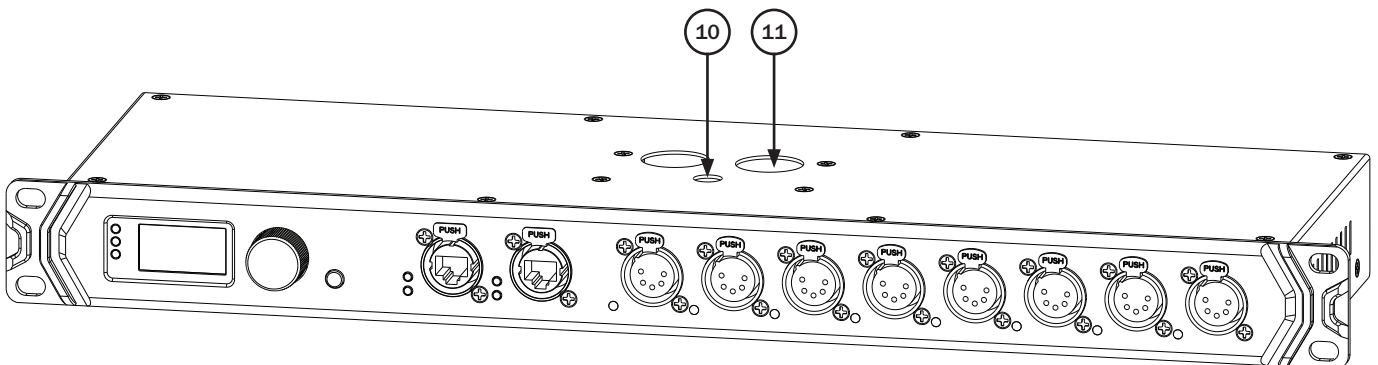
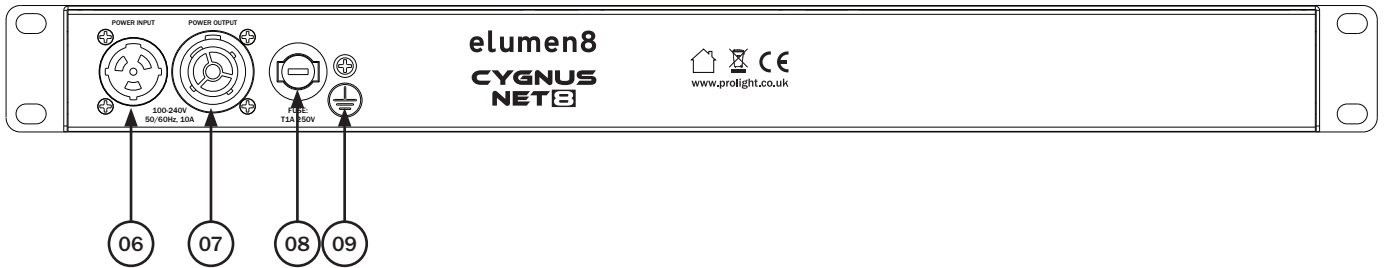
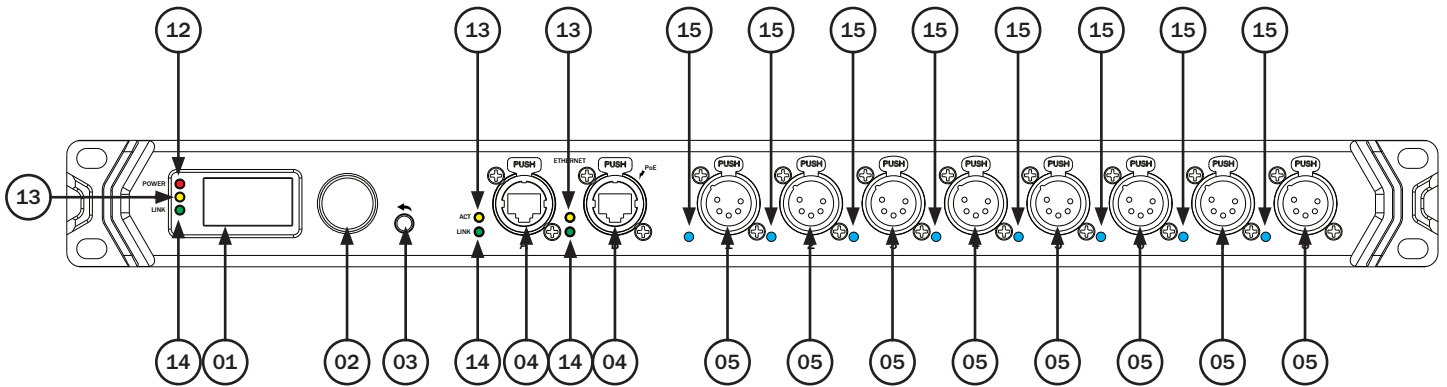

- 01 - 1.8" OLED display
- 02 - Rotary control knob
- 03 - Back to the previous menu
- 04 - RJ45 ethernet
- 05 - 5-Pin Seetronic outputs
- 06 - Power Twist TR1 input
- 07 - Power Twist TR1 output
- 08 - Fuse T1A 250V
- 09 - Earth point
- 10 - M10 mounting point
- 11 - Safety eye
- 12 - Power indicator
- 13 - Network indicators
- 14 - Link indicators
- 15 - DMX signal indicators

In the box:
1 x Cygnus NET8,
1 x power cable

Installation:

1. Pull the safety cable through the safety cable holes located on the top of the fixture.
2. Insert the omega clamp quick-lock fasteners into the corresponding holes on the top of the unit.
Tighten locking fastener clockwise ensuring it's fully secure.
3. Mount the fixture onto your truss system via the clamp and tighten to ensure secure.
4. Pull the safety cable around the truss.

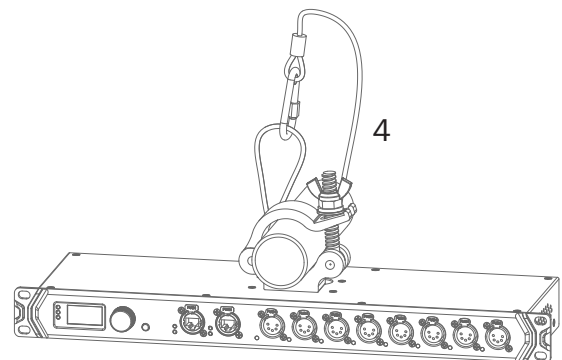
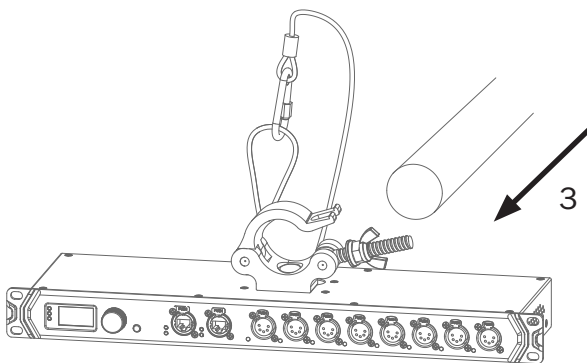
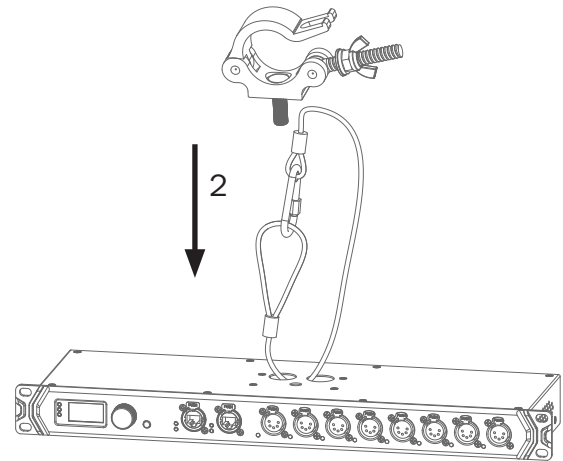
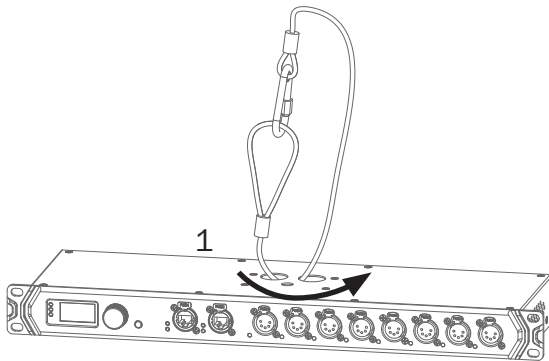

Installation:

1. Insert the unit into the rack and align the mounting holes with the rack rails.
2. Secure the unit to the rack using the mounting screws.

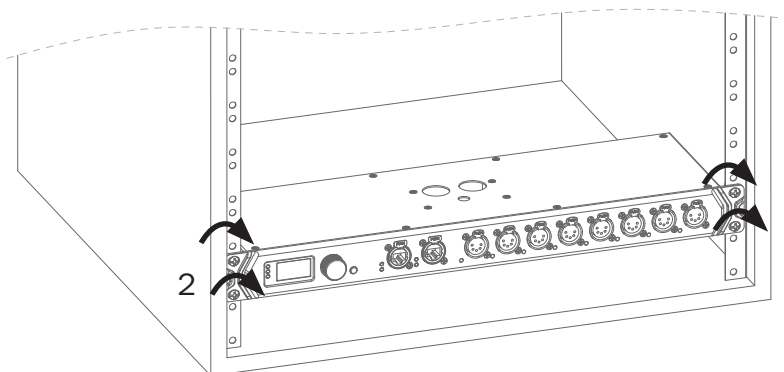
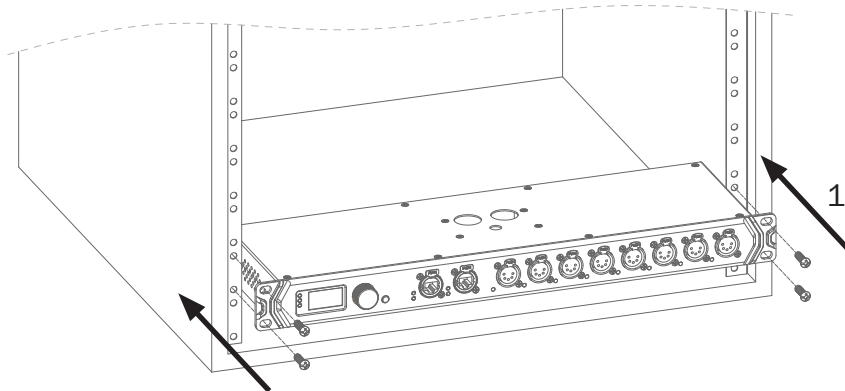
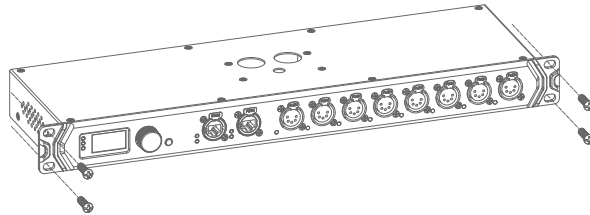

Setup:

Connect an RJ45 cable from a lighting console or laptop to the one of RJ45 inputs on the front panel.

The NET8 has 8 x 5-pin XLR DMX outputs. From each output, you can connect up to 32 fixtures per DMX line, with a maximum cable length of 100 m.

Once the lighting controller and fixtures are connected to the NET8, power the device via the Seetronic Power Twist TR1 power input on the rear panel.

LED indicators:

The Cygnus NET8 is fitted with a number of LED indicators, their functions are detailed below.

POWER – The power indicator located on the left of the front panel will illuminate red to indicate the unit is receiving power.

STATE – The indicator located on the bottom of the front panel, will:

- flash blue to indicate that no DMX signal detected
- illuminate blue to indicate that the device is receiving a DMX signal
- illuminate blue/red to indicate that an error has been detected
- illuminate purple to indicate that DMX output has been set to sent value
- illuminate green to indicate that DMX output has been set to input
- flash green to indicate that DMX port output been set to input but no date detected.

ACT – The indicator located in the middle of the rear panel, will:

- illuminate yellow to indicate when there is network activity

LINK – The indicator located in the middle of the rear panel, will:

- illuminate green to indicate when a network signal is received.

Menu:

IP:2:000:000:001									
A	B	1	2	3	4	5	6	7	8
x	x	x	x	x	x	x	x	x	x
P1-4		Art		Art		Art		Art	
P5-8		Art		Art		Art		Art	

IP:2:000:000:001									
A	B	1	2	3	4	5	6	7	8
x	x	0	0	0	0	0	0	0	0
P1-4		001		002		003		004	

IP:2:000:000:001									
A	B	1	2	3	4	5	6	7	8
x	x	0	0	0	0	0	0	0	0
P5-8		005		006		007		008	

Menu:

Main Menu	Sub Menu	
1. Set DMX Port	Port 1	1. Mode: Input, Output, Send Value or Disable 2. Universe: 0-32766 3. Protocol: Art-Net, sACN or None 4. Frame Rate: 10Hz, 15Hz, 20Hz, 25Hz, 30Hz, 35Hz or 40Hz 5. RDM: Enable or Disable 6. Merge: Single, HTP, LTP,
	Port 2	
	Port 3	
	Port 4	
	Port 5	
	Port 6	
	Port 7	
	Port 8	
2. Set IP Mode	1. DHCP IP	
	2. Automatic 2.x	
	3. Automatic 10.x	
	4. Custom IP	
	5. Automatic 192.x	
	6. Automatic 172.x	
3. Set Netmask	255.000.xxx.xxx	
	Cancel Enter	
4. User Preset	1. ArtNet 2.x	
	2. ArtNet 10.x	
	3. ArtNet 192.x	
	4. ArtNet 172.x	
	5. ArtNet DHCP	
	6. ArtNet In	
	7. ArtNet In/Thru	
	8. sACN 2.x	
	9. sACN 10.x	
	10. sACN 192.x	
	11. sACN 172.x	
	12. sACN DHCP	
	13. sACN In	
	14. Splitter Port1	
5. Device Settings	1. Device Label	NET8-----
	2. Device ID	
	3. Display	1. Display Timeout: 10 Sec, 30 Sec, 1 Min, 5 Min, 10 Minor or Disable
		2. LED Brightness: 0-10
	4. Art-Net Offset	1. Universe 1:0-0
		2. Universe 1:0-1
	5. Startup	1. Wait for Data
		2. Send 0

Menu:

Main Menu	Sub Menu	
5. Device Settings	6. Signal Loss	1. Hold Timeout: Forever, 0 Sec, 10 Sec, 30 Sec, 1Min, 5 Min, 10 Min, 60Min
		2. Loss Mode
	7. RDM Processing	1. Fade to 0 (0-60 Sec)
		2. Disable DMX
6. Default Settings	Restore all settings	
	Yes No	
7. Information	1. Software Version	1. Firmware V0.x
		2. Web Ver V1.x
	2. MAC Address	xx:xx:xx:xx:xx:xx
	3. RDM UID	0x09A5-xxxxxxx

Setup via web browser:

To access and configure the device via a web interface.

Connect the device to a laptop or computer.

Set laptop/computer IP address to a static IP in the same range as device e.g. 2.0.0.20, Subnet mask: 255.000.000.000

Open a web browser and enter the device IP address.

To access the device status and DMX port information press **Home** tab.

		IP:2:000:000:001							
A	B	1	2	3	4	5	6	7	8
x	x	x	x	x	x	x	x	x	x
P1-4		Art		Art		Art		Art	
P5-8		Art		Art		Art		Art	

The **Device** section shows:

- **Device Name**
- **IP Address:** 2.x.x.x or 10.x.x.x
- **Net Mask:** 255.000.xxx.xxx

The **DMX Ports** section shows:

- **Port Number**
- **Mode (Input/Output)**
- **Protocol (e.g. Art-Net)**
- **Universe**
- **Frame Rate**
- **RDM Status**

CYGNUS **elumen8**

Home Presets DMX Ports Network System Info

Status

Device

Device Name: NET8
IP Address: 002.000.000.001
Net Mask: 255.000.000.000

DMX Ports

Port#	Mode	Protocol	Universe	Frame Rate	RDM
1	Output	Art-Net	1	35Hz	Enable
2	Output	Art-Net	2	35Hz	Enable
3	Output	Art-Net	3	35Hz	Enable
4	Output	Art-Net	4	35Hz	Enable
5	Output	Art-Net	5	35Hz	Enable
6	Output	Art-Net	6	35Hz	Enable
7	Output	Art-Net	7	35Hz	Enable
8	Output	Art-Net	8	35Hz	Enable

To access or load predefined configuration presets press **Presets** tab.

CYGNUS **elumen8**

Home Presets DMX Ports Network System Info

Default Presets

Select: 1:ArtNet 2.x

Start Universe: 1

Load Preset

In **Select** option choose a preset from the list.

- **1:ArtNet 2.x**
- **2:ArtNet 10.x**
- **3:ArtNet 192.x**
- **4:ArtNet 172.x**
- **5:ArtNet DHCP**
- **6:ArtNet In**
- **7:ArtNet In/Thru**
- **8:sACN 2.x**
- **9:sACN 10.x**
- **10:sACN 192.x**
- **11:sACN 172.x**
- **12: sACN DHCP**
- **13: sACN DHCP In**

Set the **Start Universe** value as required.

Select **Load Preset** to apply the selected configuration.

To access and configure the DMX ports press **DMX Ports** tab:

To adjust the following parameters select a preset from the list or set a value:

- **Mode** – Disable, Input, Output or Send Value
- **Universe** – Set the universe value
- **Protocol** – Art-Net or sACN
- **Framerate** – Set the output frame rate: 10Hz, 15Hz, 20Hz, 25Hz, 30Hz, 35Hz or 40Hz.
- **RDM** – Enable or disable RDM
- **Merge** - Off, HTP, LTP

Press **Save** to confirm your choice.

To configure the network settings press **Network** tab:

Select **Address Mode** and choose the desired option (DHCP IP, Automatic 2.x.x.x, Automatic 10.x.x.x, Custom IP, Automatic 192.168.x.x or Automatic 172.168.x.x).

Set the following parameters:

- **IP:** 2.x.x.x or 10.x.x.x
- **Subnet:** 255.0.0.0

Press **Save** to confirm your choice.

Select **System** tab to access a list of available settings:

- **Device Settings**
- **Security**
- **Maintenance**

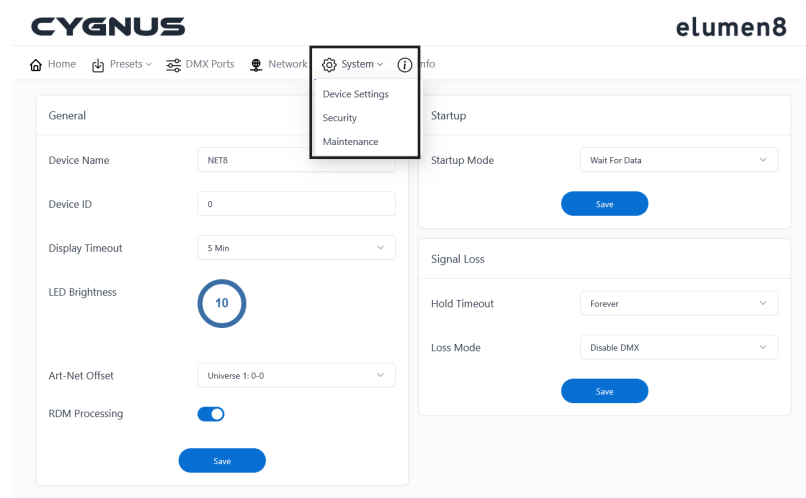

To configure general **Device settings** select one of the below option:

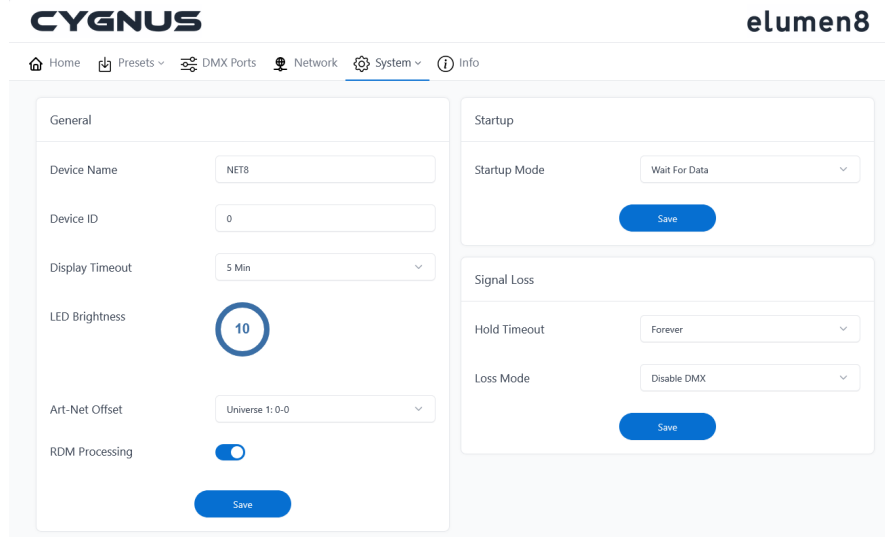

In the **General** section, set:

- **Device Name**
- **Device ID**
- **Display Timeout:** 10s, 30s, 1min, 5min, 10min or Disable
- **LED Brightness:** 0 to 10
- **Art-Net Offset:** Universe 1: 0-0 or Universe 1: 0-1
- **RDM Processing** – Enable or Disable

In the **Startup** section, set:

- **Startup Mode:** Wait for Data or Send 0

In the **Signal Loss** section, set:

- **Hold Timeout:** 0s, 10s, 30s, 1min, 5min, 10min, 60min or Forever
- **Loss Mode:** Disable DMX or Fade to 0
- **Fade Out(s):** 0-60

Press **Save** to confirm your choice.

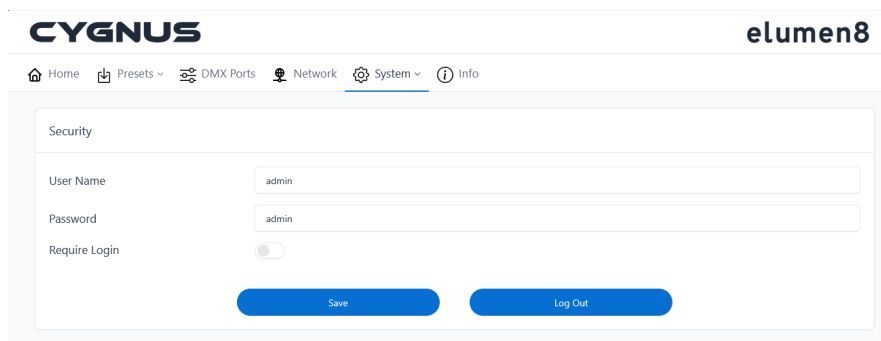

To configure login and access settings set the following parameters:

- **User Name:** admin
- **Password:** admin
- **Require Login** – Enable or disable login protection

Press **Save** to confirm your choice. Select **Log Out** to exit the current session.

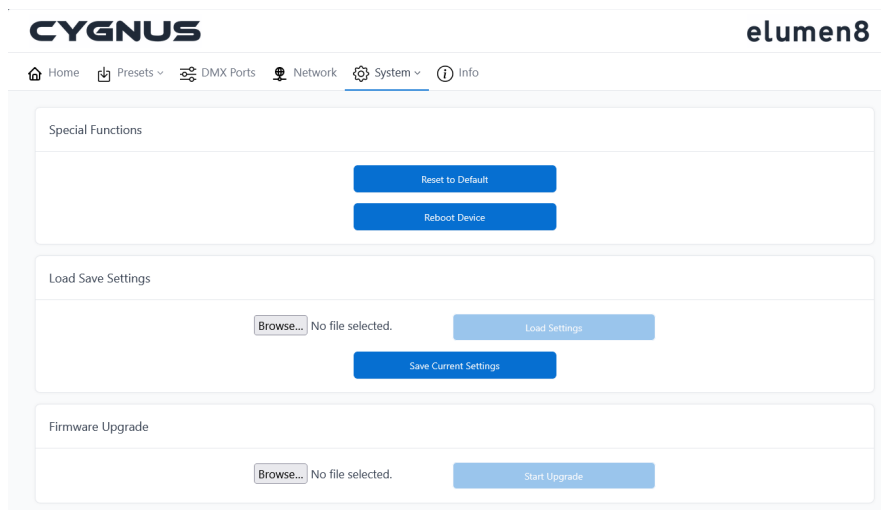

In the **System Maintenance** section you can manage device functions, settings, and firmware.

In the **Special Functions** section:

- **Reset to Default** to restore factory settings
- **Reboot Device** to restart the device

In the **Load Save Settings** section:

- **Browse** to choose a settings file
- **Load Settings** to apply saved settings
- **Save Current Settings** to create a backup file

In the **Firmware Upgrade** section:

- **Browse** to choose a firmware file
- **Start Upgrade** to update the device firmware

In this menu you can view device and firmware **Information**.

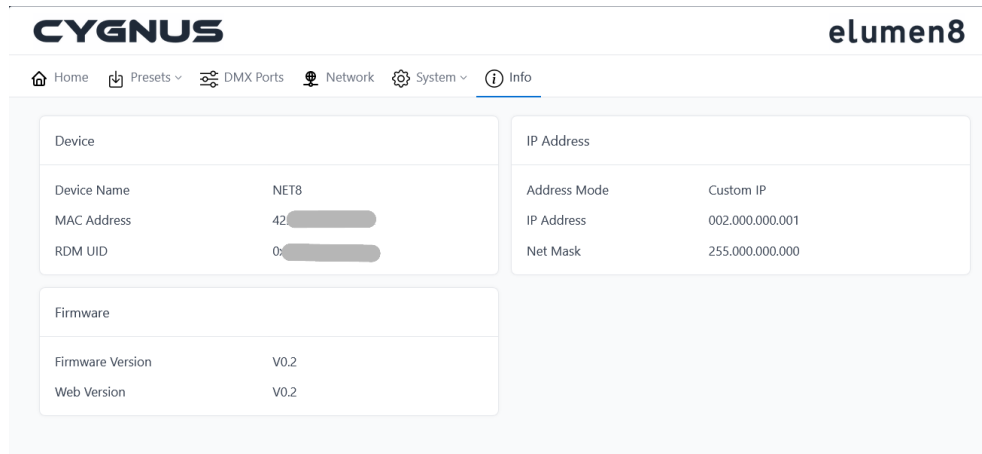

In the **Device** section, view:

- **Device Name**
- **MAC Address**
- **RDM UID**

In the **IP Address** section, view:

- **Address Mode**
- **IP Address**
- **Net Mask**

In the **Firmware** section, view:

- **Firmware Version**
- **Web Version**

This menu is for information only and cannot be edited.

Example connection diagram (Art-Net/sAcn to DMX output):

Note: Please link all cables before connecting power.

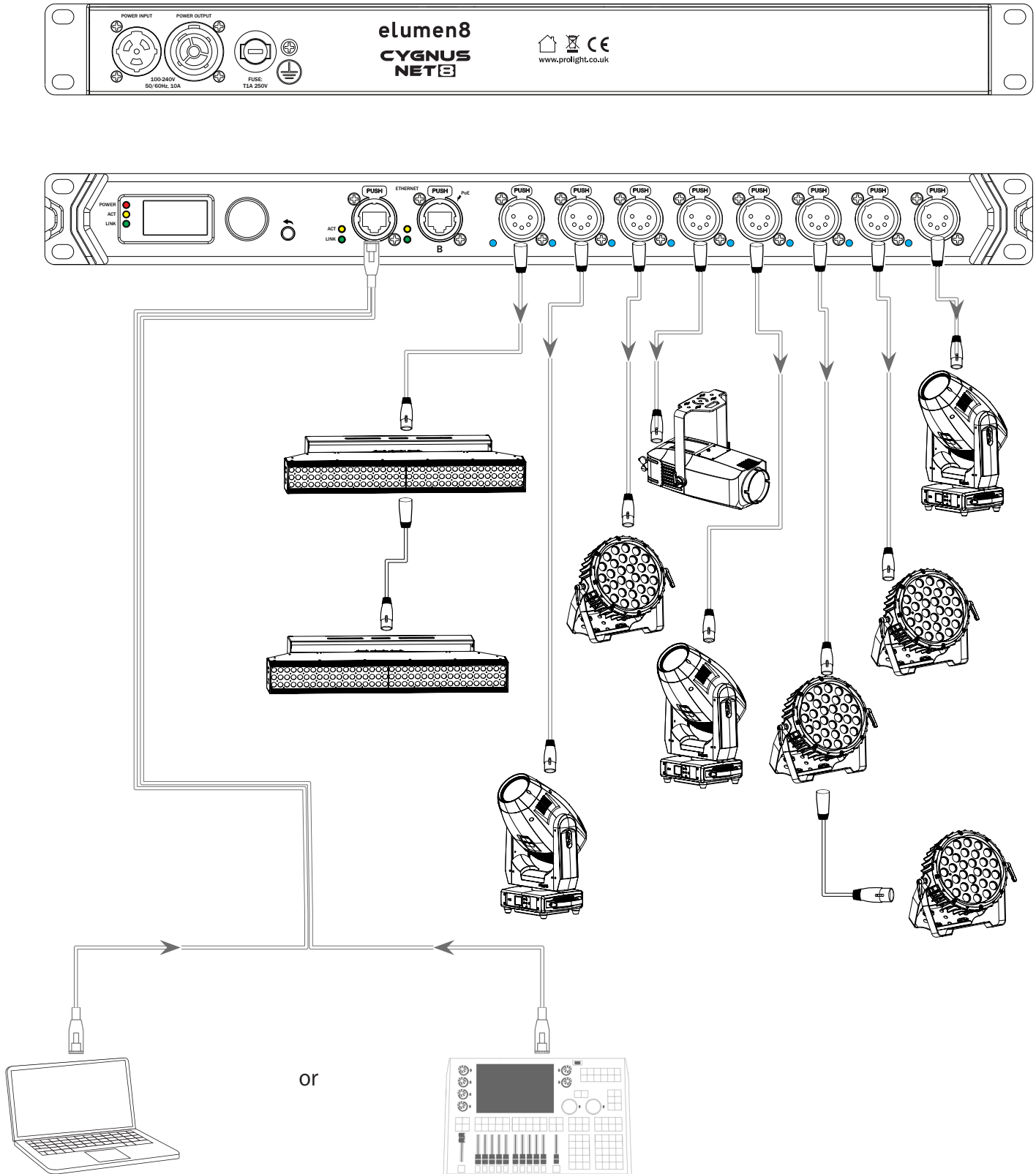

Example connection diagrams (DMX input to Art-Net/sAcn):

Note: Please link all cables before connecting power.

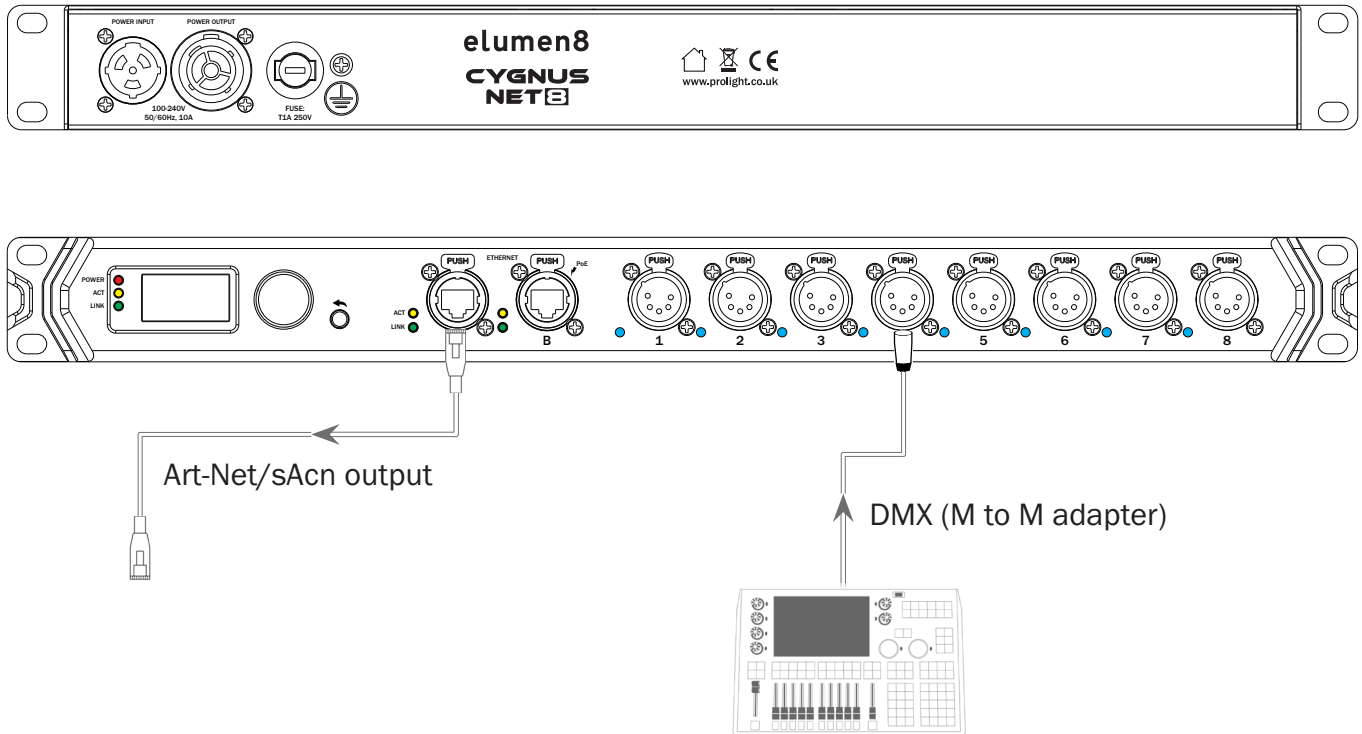

Setting the DMX address:

The DMX mode enables the use of a universal DMX controller. Each fixture requires a “start address” from 1- 512. A fixture requiring one or more channels for control begins to read the data on the channel indicated by the start address. For example, a fixture that occupies or uses 7 channels of DMX and was addressed to start on DMX channel 100, would read data from channels: 100, 101, 102, 103, 104, 105 and 106. Choose a start address so that the channels used do not overlap. E.g. the next unit in the chain starts at 107.

DMX 512:

DMX (Digital Multiplex) is a universal protocol used as a form of communication between intelligent fixtures and controllers. A DMX controller sends DMX data instructions from the controller to the fixture. DMX data is sent as serial data that travels from fixture to fixture via the DATA “IN” and DATA “OUT” XLR terminals located on all DMX fixtures (most controllers only have a data “out” terminal).

DMX linking:

DMX is a language allowing all makes and models of different manufacturers to be linked together and operate from a single controller, as long as all fixtures and the controller are DMX compliant. To ensure proper DMX data transmission, when using several DMX fixtures try to use the shortest cable path possible. The order in which fixtures are connected in a DMX line does not influence the DMX addressing. For example; a fixture assigned to a DMX address of 1 may be placed anywhere in a DMX line, at the beginning, at the end, or anywhere in the middle. When a fixture is assigned a DMX address of 1, the DMX controller knows to send DATA assigned to address 1 to that unit, no matter where it is located in the DMX chain.

DATA cable (DMX cable) requirements (for DMX operation):

This fixture can be controlled via DMX-512 protocol. The DMX address is set on the back of the unit. Your unit requires either a standard 3-pin or 5-pin XLR connector for data input/output, see images below. Using audio XLR cables for DMX lighting is discouraged because it causes signal degradation, leading to flickering, erratic, or non-responsive lights. Audio cables have different impedance (<75 Ω) and higher capacitance, which cannot accurately transmit high-speed digital DMX data (110-120 Ω). While it may work for short, simple setups, it is unreliable for professional, long-distance, or complex lighting rigs. Ensure you use DMX XLR cables.



Further DMX cables can be purchased from all good sound and lighting suppliers or Prolight Concepts dealers.

Please quote:	3-Pin:	CABL10 – 2m	CABL11 – 5m	CABL12 – 10m
	5-Pin:	CABL185 – 2m	CABL187 – 5m	CABL188 – 10m

Also remember that DMX cable must be daisy chained and cannot be split.

Notice:

Be sure to follow the diagrams below when making your own cables. Do not connect the cables shield conductor to the ground lug or allow the shield conductor to come in contact with the XLRs outer casing. Grounding the shield could cause a short circuit and erratic behaviour.

Pin Configuration	
3-Pin	5-Pin
	Pin 1 - Ground
	Pin 2 - Negative
	Pin 3 - Positive
-	Pin 4 - N/C
-	Pin 5 - N/C

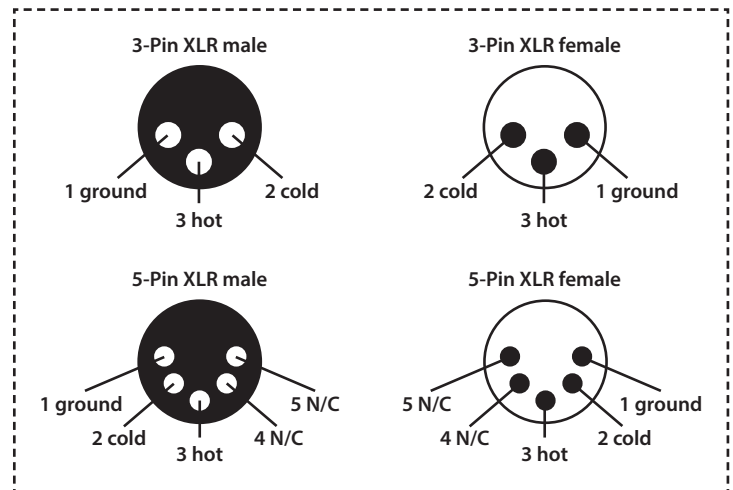
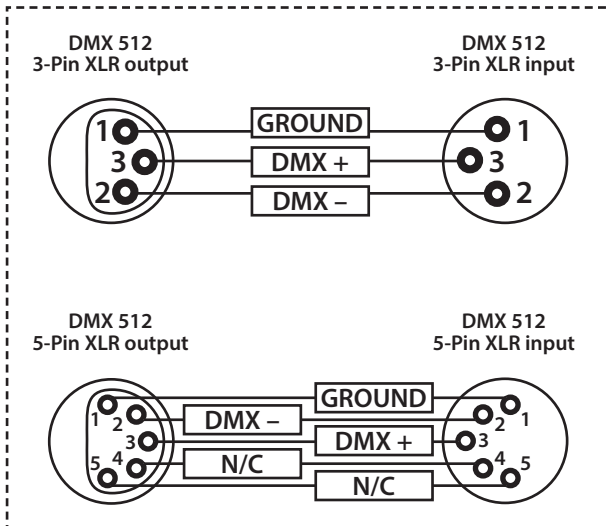

Line termination:

When longer runs of cable are used, you may need to use a terminator on the last unit to avoid erratic behaviour.

Using a cable terminator will decrease the possibilities of erratic behaviour.

(3-pin - Order ref: CABL90,
5-pin - Order ref: CABL89)

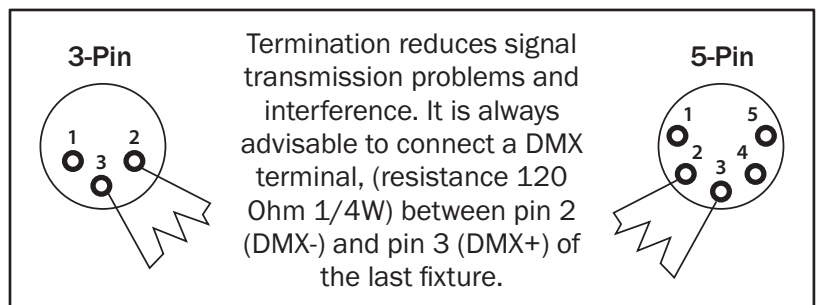

5-pin XLR DMX connectors:

Some manufacturers use 5-pin XLR connectors for data transmission in place of 3-pin. 5-pin XLR fixtures may be implemented in a 3-pin XLR DMX line. When inserting standard 5-pin XLR connectors in to a 3-pin line a cable adaptor must be used. The diagram below details the correct cable conversion.

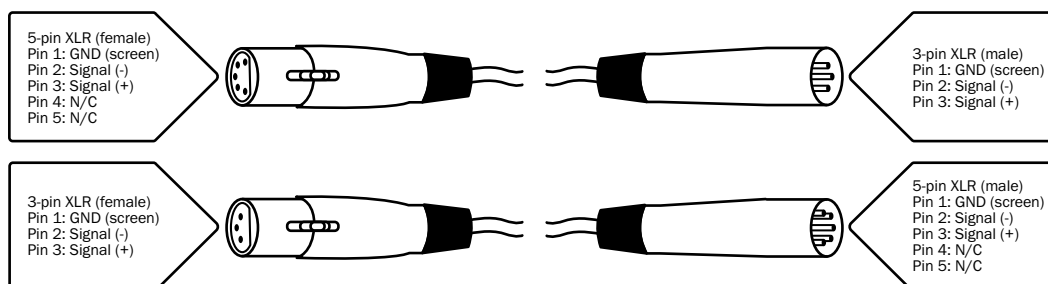



***Correct Disposal of this Product
(Waste Electrical & Electronic Equipment)***

**(Applicable in the European Union and other European countries
with separate collection systems)**

This marking shown on the product or its literature, indicates that it should not be disposed with other household wastes at the end of its working life. To prevent possible harm to the environment or human health from uncontrolled waste disposal, please separate this from other types of wastes and recycle it responsibly to promote the sustainable reuse of material resources.

Household users should contact either the retailer where they purchased this product, or their local government office, for details of where and how they can take this item for environmentally safe recycling.

Business users should contact their supplier and check the terms and conditions of the purchase contract. This product should not be mixed with other commercial wastes for disposal.

This notice does not imply a requirement for the product to be returned to the manufacturer or supplier, disposal should be carried out via appropriate authorised recycling facilities in accordance with local regulations.

