

elumen8

Evora 200 Hybrid User Manual



Order codes: ELUM705

WARNING

FOR YOUR OWN SAFETY, PLEASE READ THIS USER MANUAL CAREFULLY BEFORE YOUR INITIAL START-UP!

- Before your initial start-up, please make sure that there is no damage caused during transportation.
- Should there be any damage, consult your dealer and do not use the equipment.
- To maintain the equipment in good working condition and to ensure safe operation, it is necessary for the user to follow the safety instructions and warning notes written in this manual.
- Please note that damages caused by user modifications to this equipment are not subject to warranty.



IMPORTANT:

The manufacturer will not accept liability for any resulting damages caused by the non-observance of this manual or any unauthorised modification to the equipment.

- Never let the power cable come into contact with other cables. Handle the power cable and all mains voltage connections with particular caution!
- Never remove warning or informative labels from the unit.
- Do not open the equipment and do not modify the unit.
- Do not connect this equipment to a dimmer pack.
- Do not switch the equipment on and off in short intervals, as this will reduce the system's life.
- Only use the equipment indoors.
- Do not expose to flammable sources, liquids or gases.
- Always disconnect the power from the mains when equipment is not in use or before cleaning! Only handle the power-cable by the plug. Never pull out the plug by pulling the power-cable.
- Make sure that the available mains supply voltage is between 100~240V AC, 50/60Hz.
- Make sure that the power cable is never crimped or damaged. Check the equipment and the power cable periodically.
- If the equipment is dropped or damaged, disconnect the mains power supply immediately and have a qualified engineer inspect the equipment before operating again.
- If the equipment has been exposed to drastic temperature fluctuation (e.g. after transportation), do not connect power or switch it on immediately. The arising condensation might damage the equipment. Leave the equipment switched off until it has reached room temperature.
- If your product fails to function correctly, stop use immediately. Pack the unit securely (preferably in the original packing material), and return it to your Prolight dealer for service.
- Only use fuses of same type and rating.
- We recommend this fixture should be serviced at least once every 3 months to prevent build-up of dust, dirt and debris that could affect the fixtures operation.
- Repairs, servicing and power connection must only be carried out by a qualified technician. THIS UNIT CONTAINS NO USER SERVICEABLE PARTS.
- This lighting fixture is for professional use only - it is not designed for or suitable for household use. The product must be installed by a qualified technician in accordance with local territory regulations. The safety of the installation is the responsibility of the installer. The fixture presents risks of severe injury or death due to fire hazards, electric shock and falls.
- High power lighting fixtures are capable of producing powerful, concentrated beams of light that can create a fire hazard or a risk of eye injury if the safety precautions are not followed.
- WARRANTY: Two years from date of purchase.

OPERATING DETERMINATIONS

If this equipment is operated in any other way, than those described in this manual, the product may suffer damage and the warranty becomes void. Incorrect operation may lead to danger e.g: short-circuit, burns and electric shocks etc. Do not endanger your own safety and the safety of others!

Incorrect installation or use can cause serious damage to people and/or property.

This fixture falls under Protection Class 1, therefore it has to be connected to a mains socket with a protective earthing connection.

Risk group 2, RG-2: CAUTION!
Do not stare at exposed LED in operation as it may damage/be harmful to the eyes. Avoid looking directly into the light source.

CAUTION!
The maximum ambient temperature (T_a) of 40° must not be exceeded.

CAUTION!
If the lens gets damaged ie. cracks or deep scratches so the output is impaired then it must be replaced.

CAUTION!
To avoid damage to internal parts ie. optics, colour filters, gobos, prisms, frost filters, iris, shutters, motors, belts, wiring or LEDs. Never expose the lens to direct sunlight, lighting fixtures or lasers even when the fixture is not in use.

Evora 200 Hybrid

The Evora 200 Hybrid is a feature packed 3-in-1 moving head boasting a comprehensive list of features all contained in a compact housing. The 200W LED paired with an adjustable zoom from 3° to 34° allows super tight beams and wide spots to be achieved. The 200 Hybrid offers both static and rotating gobo wheels, 2 rotating prisms, a variable frost filter, 11 colours and motorised focus. Suited to rental, stage and touring the fixture is equipped with TRUE1 connections and has battery backup for offline configuration. Control is via DMX, RDM, Kling-Net, Art-NET and sACN protocols, and for further convenience wireless DMX is onboard via W-DMX Sweden.

- 2 year warranty
- 1 x 200W white LED (11,000K)
- Adjustable beam angle: 3° - 34°
- Lumens - Source: 10,500
- Lumens - Output: 5,171
- 3° - 131,459 Lux @ 2m, 34° - 7,742 Lux @ 2m
- Refresh rate: 14 selectable presets between 900Hz-25kHz
- Motorised zoom and focus
- 8 facet circular rotating indexable prism plus 5 facet linear rotating indexable prism
- Frost filter
- CRI: 70
- Gobo wheel 1: 8 rotating, indexable, replaceable gobos + open
- Gobo wheel 2: 14 static gobos + open
- Colour wheel: 11 colours + open
- Control protocols: DMX, Kling-net, Art-net and sACN
- DMX channels: 17/21 or 24 selectable
- Wireless control (W-DMX Sweden transceiver)
- RDM (Remote Device Management)
- Auto, manual control and primary/secondary modes
- Pan/tilt auto correction
- 16-Bit pan/tilt positioning
- Pan: 540° or 630° selectable, Tilt: 270°
- 0-100% dimming
- 5 dimming modes: Standard, stage, TV, architectural and theatre
- Variable strobe
- Quick release omega clamps included
- 6 button menu with 1.8" LCD display
- Display battery backup for offline configuration
- USB port (firmware updates)
- powerCON TRUE1 input/output
- 5-Pin XLR input/output
- etherCON input/output
- Temperature controlled fans



Specifications	Evora 200 Hybrid
Power consumption	320W
Fuse	T4A 250V
Power supply	100~240V, 50/60Hz
Noise level	43dBA @ 1m (low speed), 48dBA @ 1m (auto speed), 50dBA @ 1m (high speed)
Dimensions (H x W x D)	530 x 302 x 203mm
Weight	14kg
Order code	ELUM705

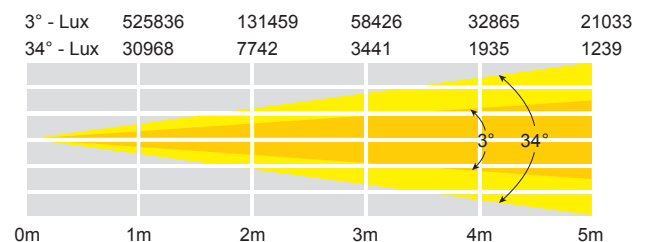

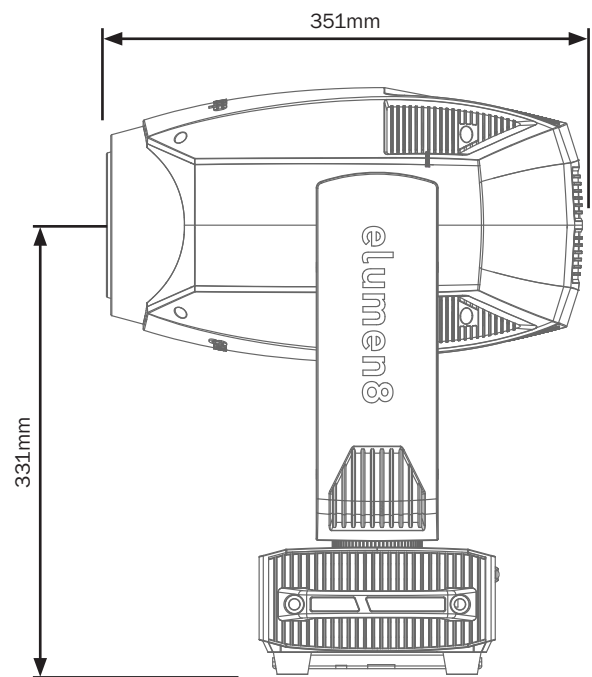
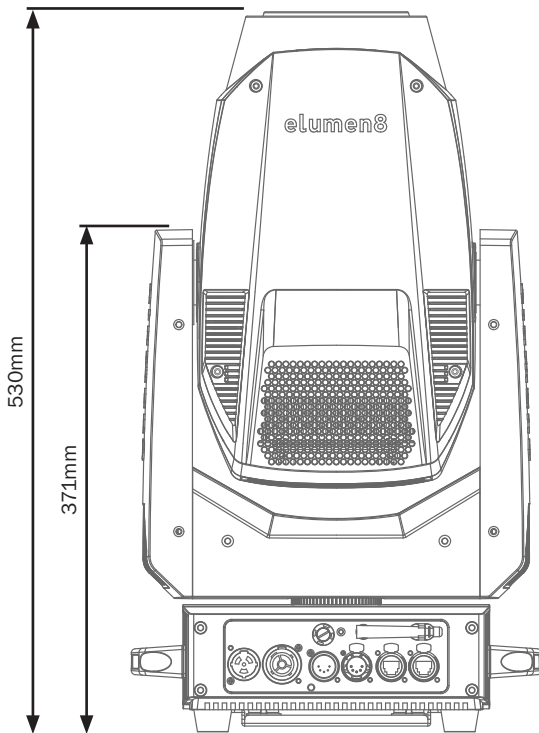
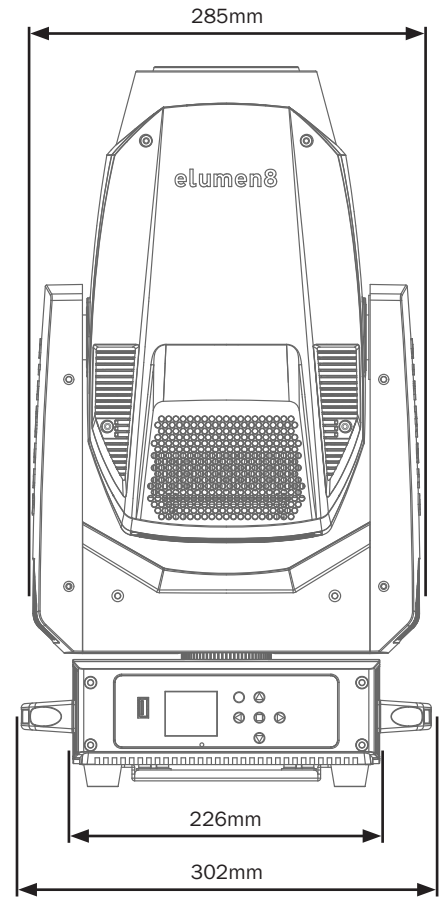
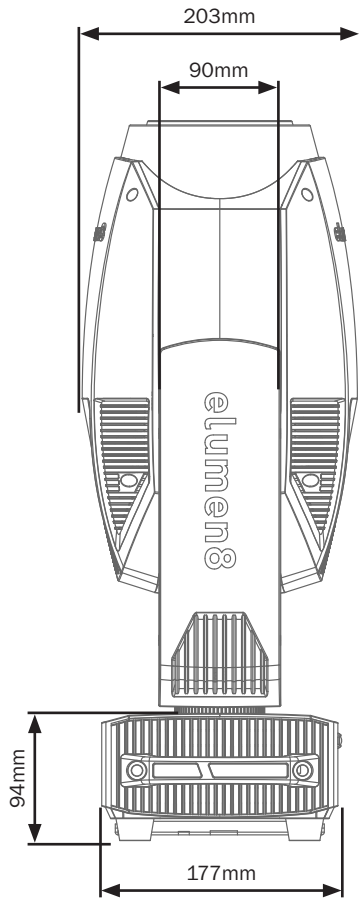

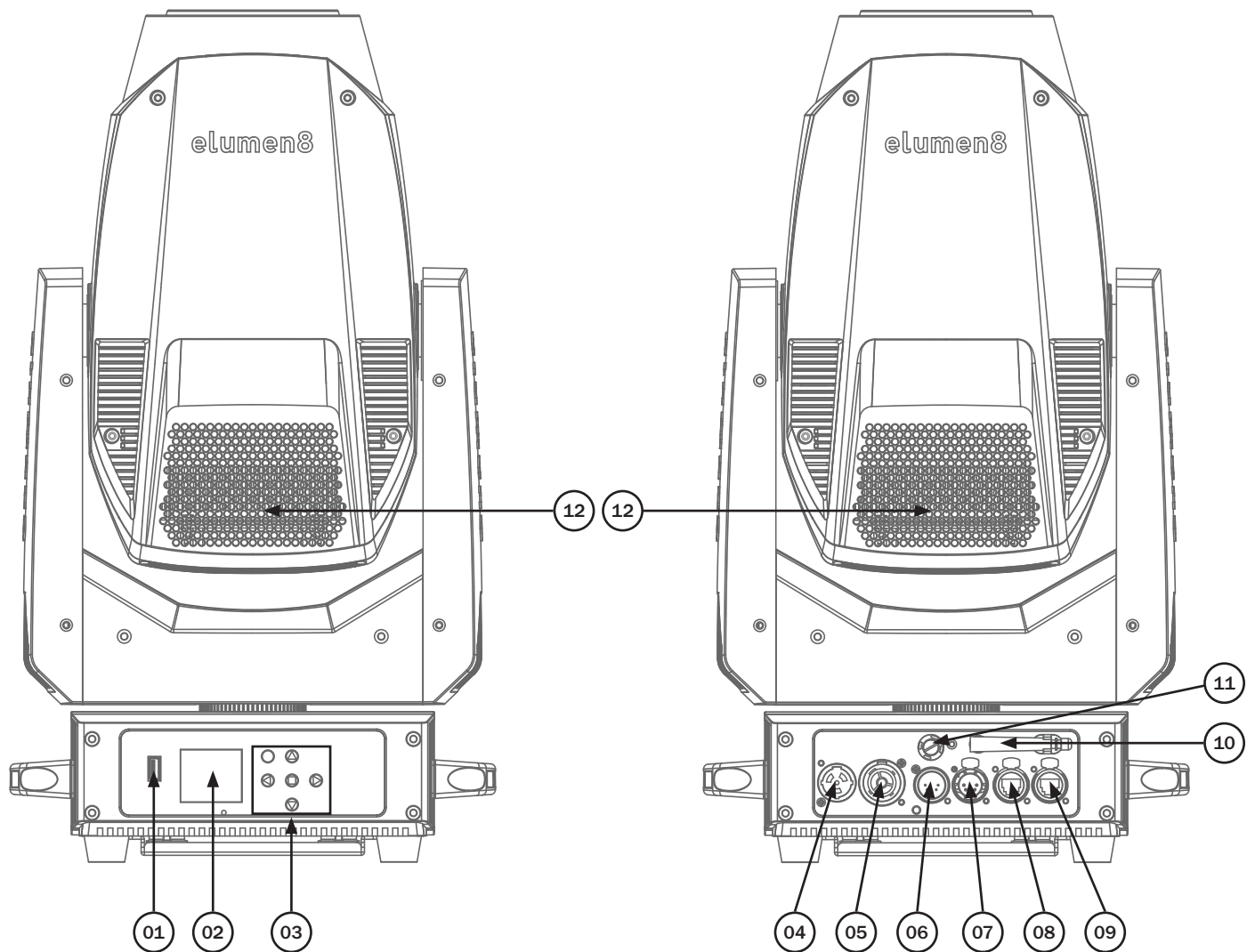

01 - USB port

02 - LCD display

03 - Function buttons

04 - powerCON TRUE1 input

05 - powerCON TRUE1 output

06 - 5-Pin DMX input

07 - 5-Pin DMX output

08 - etherCON input

09 - etherCON output

10 - Fuse T8A 250V

11 - Wireless DMX Antenna

12 - Fans

In the box: **1 x fixture,**
2 x omega clamps
& 1 x power cable

Before installing the fixture, the supporting structure (ie. truss) must be able to hold a minimum of 10 times the fixtures weight without any deformation (eg. 15kg - 150kg point load). The fixture must be secured with a secondary safety attachment when being installed (ie. an appropriate safety cable). Never stand directly below the fixture when mounting, removing, and/or servicing.

Overhead installation requires experience and qualifications to calculate working load limits, the material being used at the installation area and periodic safety inspections of the fixture and installation material. If you do not have the relevant experience and/or qualifications please do not attempt the installation yourself. The installation should be checked annually by a qualified person.

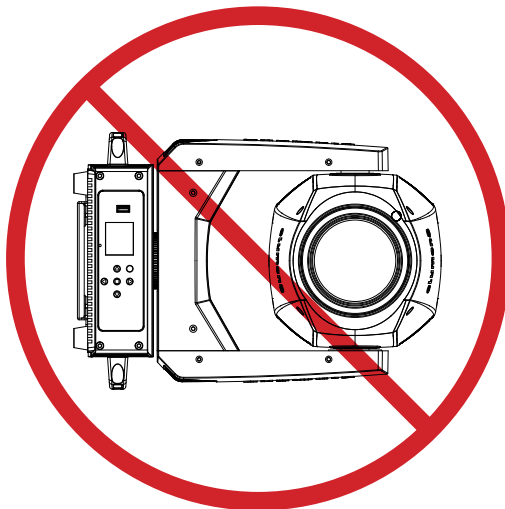
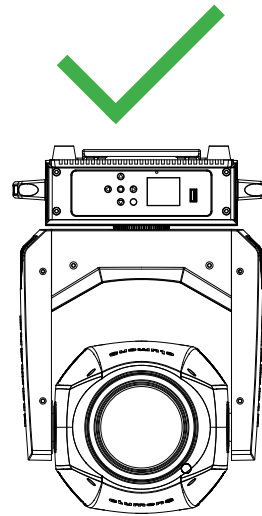
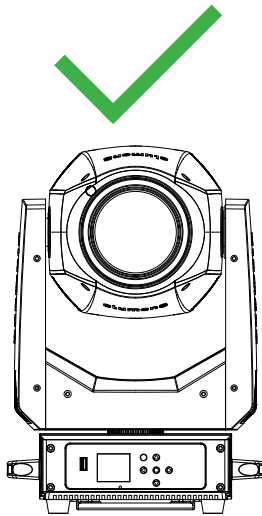

The Elumen8 Evora 200 Hybrid can be operated where the base of the fixture is horizontally orientated, this includes standing the fixture upright on a flat, level surface or hanging the fixture upside down. Do NOT install the fixture in a sideways position or in a position where the base of the fixture is orientated vertically or at an angle. Always use a safety wire as an extra safety precaution to prevent damage/injury in the event a clamp fails (see the next page for clamp installation). Never use the carry handles for secondary attachments.

Installation:

1. Fasten each clamp to the omega clamps with a bolt and lock nut through the hole in the omega clamp.
2. Align and insert the omega clamp quick-lock fasteners with the respective holes on the bottom of the unit.
3. Tighten both locking fasteners clockwise on each omega clamp ensuring they're fully secure.
4. Mount the fixture onto your truss system via the clamps and tighten to ensure secure.
5. Pull the safety cable through the safety cable holes located on the metal base plate on the underside of the fixture and around the truss.

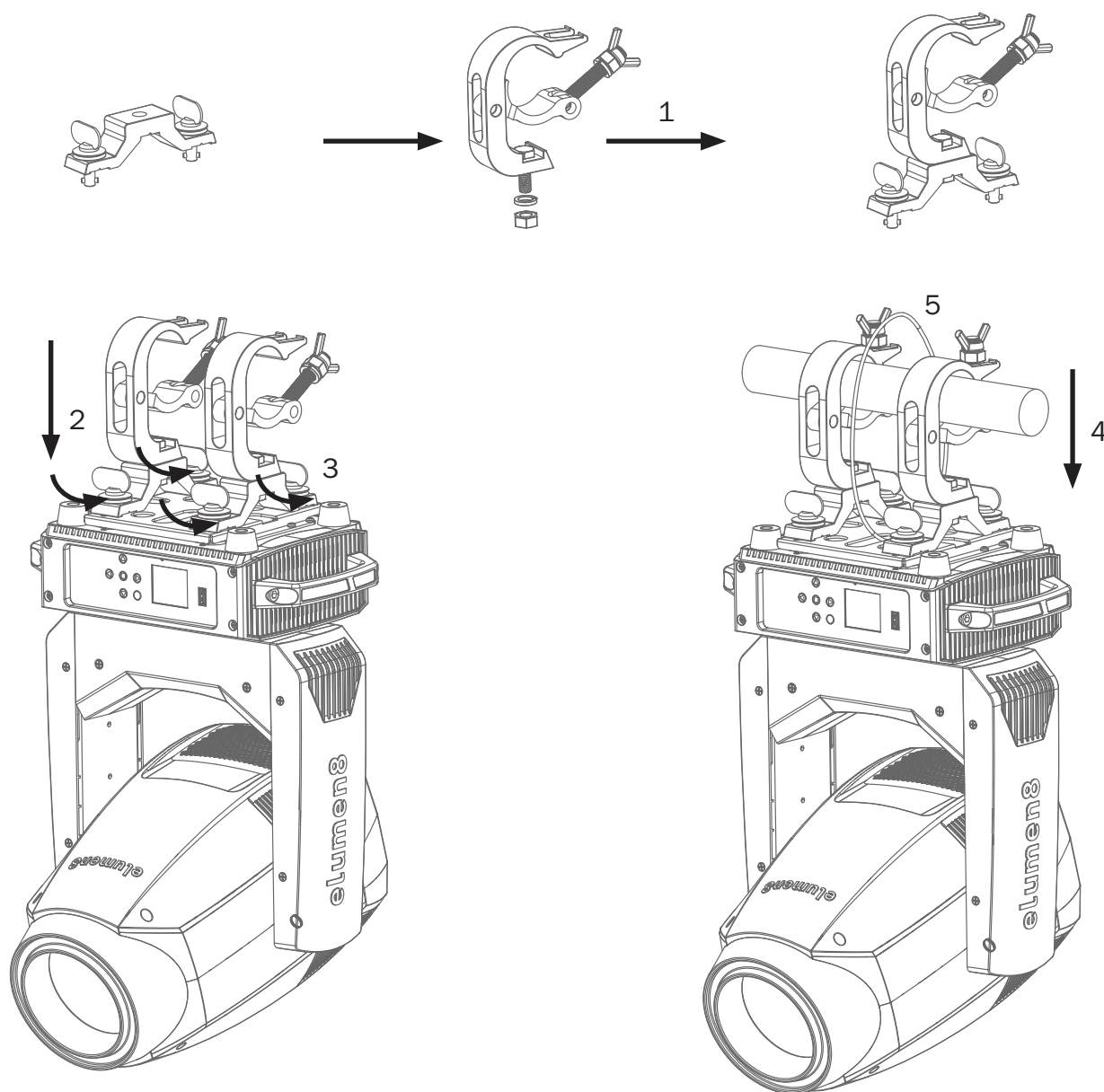

Rotating Gobo Replacement:

The fixture is supplied with 8 rotating, replaceable gobos. See below for installation instructions.

- 1) Place the fixture on a stable, flat surface ensuring you are indoors in a dust free location. Disconnect and isolate from power and let the unit cool for at least 15 minutes.



- 2) Use a Phillips head screwdriver to loosen the four screws on each side of the head casing. These are twist lock screws and do not come free of the casing.

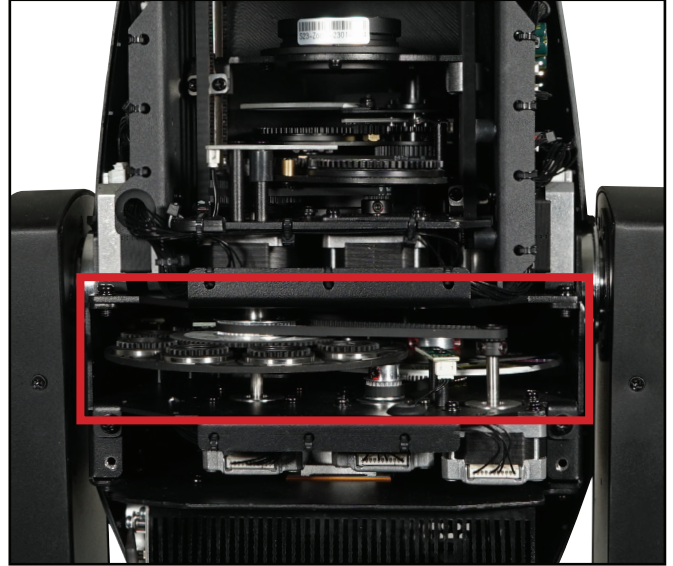

- 3) The replaceable gobo wheel is located here on the fixture. Manually spin the wheel to locate the gobo that will be replaced.

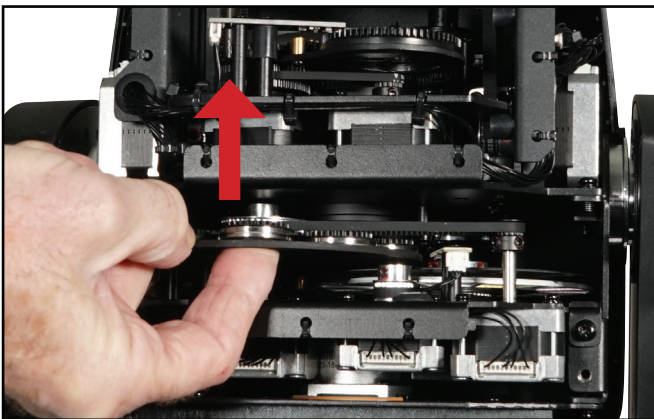

- 3) Push the gobo you are replacing up from underneath so it pops up.

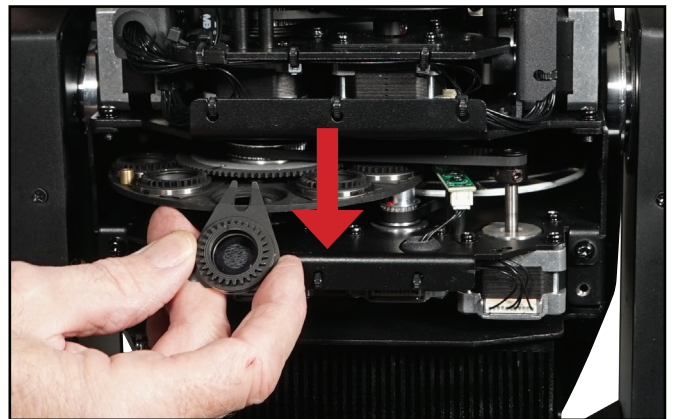

- 4) Carefully lift the gobo holder, then pull towards you, away from the gobo wheel.



- 5) Place the gobo on a flat surface with the gear side down. Locate the tab of the spring clip using a precision pick (or similar) and push the spring clip inwards to release it and remove the spring clip. Carefully remove the gobo from the holder avoiding scratching the gobo. Install the new gobo and follow the previous steps in reverse order.

Control Panel Menu:

The LCD control panel situated on the front of the fixture allows the user to access the menu system to adjust the fixtures settings.

When the unit has been powered on the display will show “**Software Update**” followed by “**Elumen8 Evora 200 Hybrid**” and then “**Ethernet Reset...**” followed by “**Motor Reset Please Wait...**”. The fixture will then return to its home screen.

Pressing the “**MENU**” button once will take the user to the fixtures main menu. Using the “**UP**” and “**DOWN**” buttons you can then navigate between the different options in the main menu. Pressing the “**ENTER**” button on one of these options allows you to access the sub menu where you can use the “**LEFT**” and “**RIGHT**” buttons to select option/value required. Once the option/value has been selected press the “**ENTER**” button once more to confirm the setting.

To exit out of any of the above options, press and hold the “**MENU**” button.

The LCD control panel can be used via the internal battery. To access this press and hold the “**MENU**” button for 5 seconds until the fixtures home screen is displayed. The LCD display will automatically shut off after 20 seconds of inactivity.

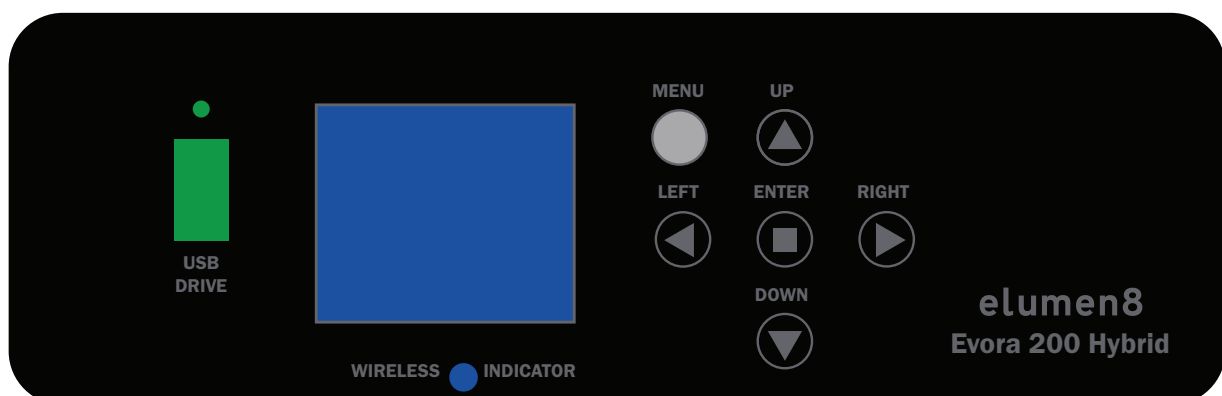

Error Codes:

When the unit is powered on the unit will automatically perform a motor reset. If there is a problem with any of the motors the display will flash and display “**Error:**” along with a list of motor errors on the LCD control panel. Please power the unit off and on to reset the motors again.

(The full list of errors codes can be found on the next page).

Error Code	Description
Pan	The movement is not located in the default position after the reset. This message will appear if the sensor has failed or magnet is missing, or if there is a motor failure (defective motor or a defective motor IC drive on the main PCB). This error may also be displayed if the yoke was blocked during a reset function.
Tilt	
ColourWheel	The movement is not located in the default position after the reset. This message will appear if the sensor has failed or magnet is missing, or if there is a motor failure (defective motor or a defective motor IC drive on the main PCB).
RotGobo	
FixGobo	
GoboRot	
Zoom	
Focus	
Prism1	
Prism1Rot	
Prism2	
Prism2Rot	
LEDTemp	This message will appear if the sensor or fan has failed or the fixtures temperature is too hot.
GoboFan	
BaseFan	
LEDTemp	

Main Menu	Sub Menu	Options/Values (Default Settings in BOLD)		Description
DMX Address		001-512		DMX Address Setting
Channel Mode		Basic (17CH)		Channel Mode Setting
		Standard (21CH)		
		Extend (24CH)		
Network	Input	OFF		Activate/deactivate network input
		ON		
	Protocol	ArtNET		Network Protocol Setting
		sACN		
	Address	ServicePIN	000-255 (PIN = 050)	Pin to enter Address Menu
		Universe	000-255	Universe Setting (PIN Required)
		IP Address	xxx.xxx.xxx.xxx (002.000.000.002)	IP Address Setting (PIN Required)
		Subnet Mask	xxx.xxx.xxx.xxx (255.000.000.000)	IP Subnet Mask Setting (PIN Required)
	DMX Output	OFF		Output network signal via DMX
		ON		
Wireless	W-DMX	OFF		Activate/deactivate W-DMX
		ON		
	Transmit/Receive	Transmit		Configure W-DMX as a transmitter/receiver
		Receive		
	W-DMX Protocol	G3		G3 Transmission Standard
		G4S		G4S Transmission Standard
	Tx/Rx Link	Link		Link with W-DMX devices. W-DMX must be active for all devices and the link with a transmitter must be suspended (Receive Reset)
		UnLink		Unlink all devices
	Rx Reset	NO		Do not suspend link with transmitter
		YES		Suspend link with transmitter

Main Menu	Sub Menu	Options/Values (Default Settings in BOLD)	Description	
Stand Alone	Manual Control	Pan	Manual Control Settings	
		Pan Fine		
		Tilt		
		Tilt Fine		
		Strobe		
		Dimmer		
		Dimmer Fine		
		Colour Wheel		
		Gobo 1		
		Gobo Index		
		Gobo 2		
		Prism 1		
		Prism 1 Rot		
		Prism 2		
		Prism 2 Rot		
		Focus		
		Focus Fine		
	Zoom			
	Zoom Fine			
	Frost			
	Programs	Show 1	Speed (000-255)	Internal Programs
			Fade (000-255)	
		Show 2	Speed (000-255)	
			Fade (000-255)	
		Show 3	Speed (000-255)	
			Fade (000-255)	
		Show 4	Speed (000-255)	
			Fade (000-255)	
Show 5		Speed (000-255)		
		Fade (000-255)		
Slave Mode	Slave 1 (copies primary)		Primary/Secondary Mode	
	Slave 1 (pan inverts primary)			
	Slave 1 (pan/tilt inverts primary)			

Main Menu	Sub Menu	Options/Values (Default Settings in BOLD)		Description
Service	Display	Backlight	02M-60M (06M)	LCD Backlight Setting
		Rotate 180°	OFF	LCD Display Inverse Setting
			ON	
		Key Lock	OFF	Control Panel Lock Setting (Press and hold MODE for 3 seconds to unlock)
	ON			
	DispFlash	OFF	Display Flash Setting When No DMX Signal	
		ON		
	Power Saver	Hibernation	OFF	Hibernation Setting
			01M-099M	
	DMX Fail	Blackout	DMX Fail Setting	
		Hold		
		Programs		
		Manual		
	Dim Curve	Linear	Dimming Curve Setting	
		Square Law		
		Inv Square Law		
		S-Curve		
	Dim Mode	Standard	Dimming Curve Speed	
		Stage		
		TV		
		Architecture		
		Theatre		
	Frequency	900Hz	LED Refresh Rate Setting	
		1000Hz		
		1100Hz		
		1200Hz		
		1300Hz		
		1400Hz		
		1500Hz		
		2500Hz		
		4000Hz		
		5000Hz		
10kHz				
15kHz				
20kHz				
25kHz				
Pan/Tilt	Pan Inverse	OFF	Pan Inverse Setting	
		ON		
	Tilt Inverse	OFF	Tilt Inverse Setting	
		ON		
	Pan Angle	540	Pan Angle setting	
		630		

Main Menu	Sub Menu	Options/Values (Default Settings in BOLD)		Description	
Service	Fans	Head Fan	Auto	Head Fan Setting	
			Low		
			High		
		Base Fan	Auto		Base Fan Setting
			Low		
			High		
	Calibrate (PIN = 050)	Pan		Calibration Settings	
		Tilt			
		...			
		Zoom			
	Auto Test	Testing...		Auto Test	
	Motor Reset	All		Motor Reset	
		Pan & Tilt			
Head					
USB Update	OFF		USB Update		
	ON				
Set. reset	OFF		Setting reset		
	ON				
Factory	OFF		Factory Settings		
	ON				
Information	Runtime	Total Time		Runtime Information	
		CurrentTime			
		Password (PIN = 050)			
		Reset			
	Temperature	Head	xxx°	Temperature Information	
		Base	xxx°		
		Units	C° / F°		
	Fan Speed	Head: xxxxRPM		Fan Speed Information	
		Gobo: xxxxRPM			
		Base: xxxxRPM			
	Model	Elumen8 Evora 200 Hybrid		Model Information	
	RDM UID	0x09A5-0011xxxx		RDM UID	
	Firmware	1U: Vx.x.xx		Software Version	
		2U: Vx.x.xx			
		3U: Vx.x.xx			
4U: Vx.x.xx					
5U: Vx.x.xx					
Error. Info	NONE/Pan, Tilt... (See page 13)		Current Fixture Errors		

DMX channel modes:

Channel			Value	Function	Default Value
17CH Basic	21CH Standard	24CH Extend			
1	1	1	000-255	Pan movement (540°/630°)	000
-	2	2	000-255	Pan fine	
2	3	3	000-255	Tilt movement (270°)	
-	4	4	000-255	Tilt fine	
3	5	5	000-255	Pan/tilt (fast-slow)	
4	6	6	000-255	Master dimmer (0-100%)	
-	7	7	000-255	Dimmer fine	
5	8	8	Shutter (Strobe)		000
			000-031	Shutter closed	
			032-063	Shutter open	
			064-095	Strobe (slow-fast)	
			096-127	Shutter open	
			128-159	Pulse strobe (slow-fast)	
			160-191	Shutter open	
			192-223	Random strobe (slow-fast)	
224-255	Shutter open				
6	9	9	Colour Wheel		000
			000-008	Open (white)	
			009-013	Colour 1	
			014-018	Colour 2	
			019-023	Colour 3	
			024-028	Colour 4	
			029-033	Colour 5	
			034-038	Colour 6	
			039-043	Colour 7	
			044-048	Colour 8	
			049-053	Colour 9	
			054-058	Colour 10	
			059-063	Colour 11	
			064-068	Colour 0/Colour 1	
			069-073	Colour 1/Colour 2	
			074-078	Colour 2/Colour 3	
			079-083	Colour 3/Colour 4	
			084-088	Colour 4/Colour 5	
			089-093	Colour 5/Colour 6	
094-098	Colour 6/Colour 7				
099-103	Colour 7/Colour 8				
104-108	Colour 8/Colour 9				

Channel			Value	Function	Default Value	
17CH Basic	21CH Standard	24CH Extend				
6	9	9	Colour Wheel (cont.)			000
			109-113	Colour 9/Colour 10		
			114-118	Colour 10/Colour 11		
			119-127	Colour 11/Colour 0		
			128-189	Scroll clockwise (fast-slow)		
			190-193	Stop		
			194-255	Scroll anti-clockwise (slow-fast)		
7	10	10	Rotating Gobo Wheel			000
			000-002	Beam mode		
			003-005	Spot mode		
			006-014	Rotating Gobo 1		
			015-023	Rotating Gobo 2		
			024-032	Rotating Gobo 3		
			033-041	Rotating Gobo 4		
			042-050	Rotating Gobo 5		
			051-059	Rotating Gobo 6		
			060-068	Rotating Gobo 7		
			069-077	Rotating Gobo 8		
			078-091	Rotating Gobo 1 Shake (slow-fast)		
			092-105	Rotating Gobo 2 Shake (slow-fast)		
			106-119	Rotating Gobo 3 Shake (slow-fast)		
			120-133	Rotating Gobo 4 Shake (slow-fast)		
			134-147	Rotating Gobo 5 Shake (slow-fast)		
			148-161	Rotating Gobo 6 Shake (slow-fast)		
			162-175	Rotating Gobo 7 Shake (slow-fast)		
			176-189	Rotating Gobo 8 Shake (slow-fast)		
			190-221	Scroll clockwise (fast-slow)		
222-223	Stop					
224-255	Scroll anti-clockwise (slow-fast)					
8	11	11	Rotating Gobo Wheel Index			000
			000-127	Rotating Gobo Indexing		
			127-189	Scroll clockwise (fast-slow)		
			190-193	Stop		
			194-255	Scroll anti-clockwise (slow-fast)		
9	12	12	Fixed Gobo Wheel			000
			000-007	Open		
			008-012	Gobo 1		
			013-017	Gobo 2		
			018-022	Gobo 3		
			023-027	Gobo 4		

Channel			Value	Function	Default Value
17CH Basic	21CH Standard	24CH Extend			
9	12	12	Fixed Gobo Wheel (cont.)		
			028-032	Gobo 5	000
			033-037	Gobo 6	
			038-042	Gobo 7	
			043-047	Gobo 8	
			048-052	Gobo 9	
			053-057	Gobo 10	
			058-062	Gobo 11	
			063-067	Gobo 12	
			068-072	Gobo 13	
			073-077	Gobo 14	
			078-085	Gobo 1 Shake (slow-fast)	
			086-093	Gobo 2 Shake (slow-fast)	
			094-101	Gobo 3 Shake (slow-fast)	
			102-109	Gobo 4 Shake (slow-fast)	
			110-117	Gobo 5 Shake (slow-fast)	
			118-125	Gobo 6 Shake (slow-fast)	
			126-133	Gobo 7 Shake (slow-fast)	
			134-141	Gobo 8 Shake (slow-fast)	
			142-149	Gobo 9 Shake (slow-fast)	
			150-157	Gobo 10 Shake (slow-fast)	
			158-165	Gobo 11 Shake (slow-fast)	
			166-173	Gobo 12 Shake (slow-fast)	
			174-181	Gobo 13 Shake (slow-fast)	
			182-189	Gobo 14 Shake (slow-fast)	
			190-221	Scroll clockwise (fast-slow)	
222-223	Stop				
224-255	Scroll anti-clockwise (fast-slow)				
10	13	13	Prism 1		
			000-031	Open	000
			032-255	8 facet circular prism	
11	14	14	Prism 1 Indexing / Rotation		
			000-005	Prism 1 rotation stop	000
			006-128	Prism 1 indexing	
			129-191	Clockwise prism rotation (fast-slow)	
			192	Prism 1 rotation stop	
193-255	Anti-clockwise prism rotation (slow-fast)				
12	15	15	Prism 2		
			000-031	Open	000
			032-255	6 facet linear prism	

Channel			Value	Function	Default Value
17CH Basic	21CH Standard	24CH Extend			
			Prism 2 Indexing / Rotation		
13	16	16	000-005	Prism 2 rotation stop	000
			006-128	Prism 2 indexing	
			129-191	Clockwise prism rotation (fast-slow)	
			192	Prism 2 rotation stop	
			193-255	Anti-clockwise prism rotation (slow-fast)	
14	17	17	000-255	Focus	
-	-	18	000-255	Focus fine	
15	18	19	000-255	Zoom	
-	-	20	000-255	Zoom fine	
16	19	21	000-255	Frost	
			Dimming Curves		
-	-	22	000-005	No function	000
			006-067	Linear	
			068-129	Square law	
			130-191	Inverse square law	
			192-255	S-Curve	
			Dimming Mode		
-	20	23	000-020	Standard	000
			021-040	Stage	
			041-060	TV	
			061-080	Architectural	
			081-100	Theatre	
			101-255	Default to unit setting	
			Special Functions		
17	21	24	000-015	No function	000
			016-024	Blackout while P/T on (hold 3s)	
			025-032	Blackout while P/T off (hold 5s)	
			033-040	Invert pan on (hold 3s)	
			041-048	Invert pan off (hold 5s)	
			049-056	Invert tilt on (hold 3s)	
			057-064	Invert tilt off (hold 5s)	
			065-072	Fan auto (hold 3s)	
			073-080	Fan low (hold 3s)	
			081-088	Fan high (hold 3s)	
			089-096	900Hz (hold 3s)	
			097-104	1000Hz (hold 3s)	
			105-112	1100Hz (hold 3s)	
			113-120	1200Hz (hold 3s)	
121-128	1300Hz (hold 3s)				

Channel			Value	Function	Default Value	
17CH Basic	21CH Standard	24CH Extend				
17	21	24	Special Functions (cont.)			000
			129-136	1400Hz (hold 3s)		
			137-144	1500Hz (hold 3s)		
			145-152	2500Hz (hold 3s)		
			153-160	4000Hz (hold 3s)		
			161-168	5000Hz (hold 3s)		
			169-176	10kHz (hold 3s)		
			177-184	15kHz (hold 3s)		
			185-192	20kHz (hold 3s)		
			193-200	25kHz (hold 3s)		
			201-208	Reset pan/tilt (hold 3s)		
			209-216	Reset head only (hold 3s)		
			217-224	Reset all motors (hold 3s)		
			225-232	Input off		
			233-240	Input on		
241-255	No function					

Rotating gobos:

Gobo size: 16.5mmØ Image size: 9mmØ

Gobo thickness: 1.1mm

(Max. thickness if replaced 1.1mm)

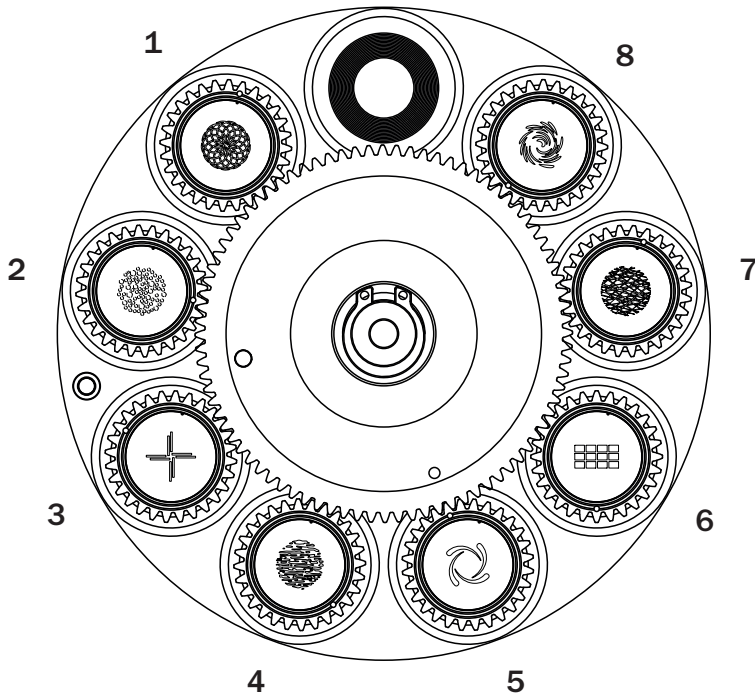

Colour wheel:

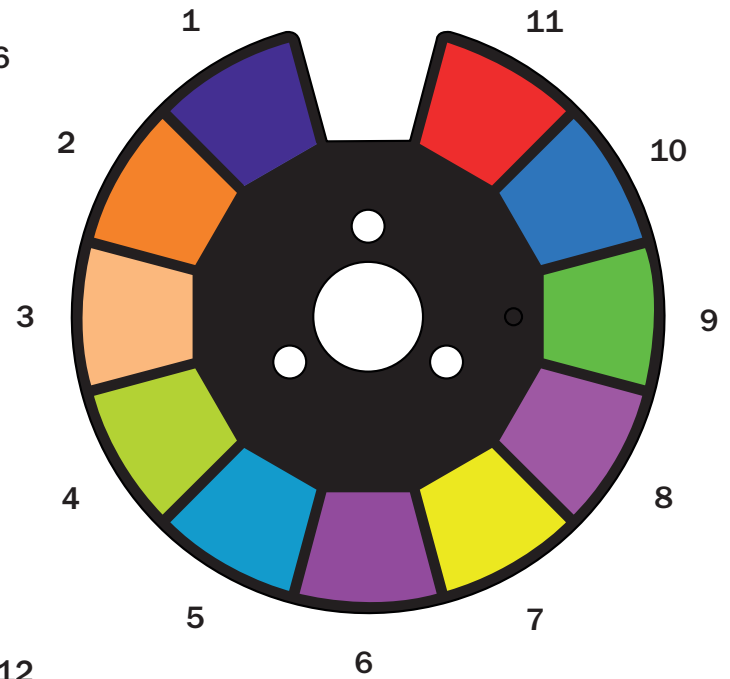

Static gobos:

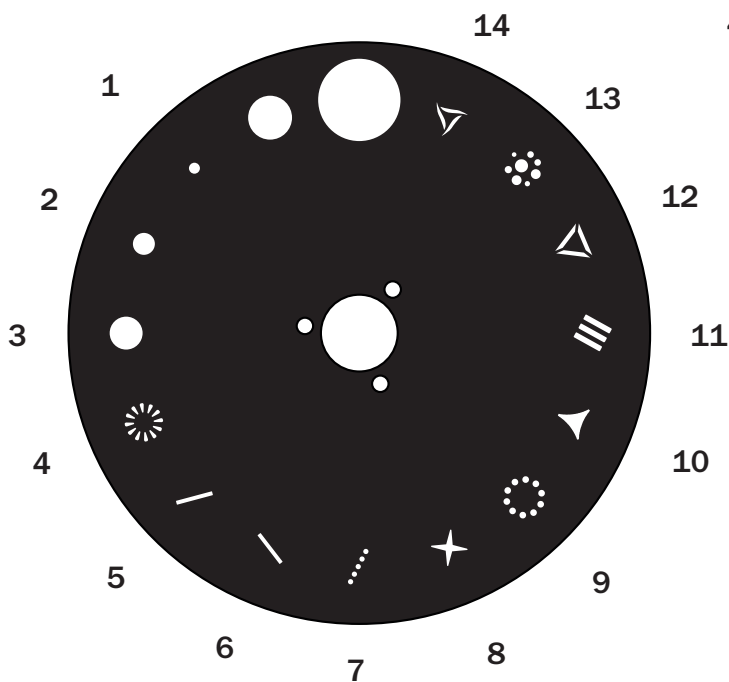

Setting the DMX address:

The DMX mode enables the use of a universal DMX controller. Each fixture requires a “start address” from 1- 512. A fixture requiring one or more channels for control begins to read the data on the channel indicated by the start address. For example, a fixture that occupies or uses 7 channels of DMX and was addressed to start on DMX channel 100, would read data from channels: 100, 101, 102, 103, 104, 105 and 106. Choose a start address so that the channels used do not overlap. E.g. the next unit in the chain starts at 107.

DMX 512:

DMX (Digital Multiplex) is a universal protocol used as a form of communication between intelligent fixtures and controllers. A DMX controller sends DMX data instructions from the controller to the fixture. DMX data is sent as serial data that travels from fixture to fixture via the DATA “IN” and DATA “OUT” XLR terminals located on all DMX fixtures (most controllers only have a data “out” terminal).

DMX linking:

DMX is a language allowing all makes and models of different manufactures to be linked together and operate from a single controller, as long as all fixtures and the controller are DMX compliant. To ensure proper DMX data transmission, when using several DMX fixtures try to use the shortest cable path possible. The order in which fixtures are connected in a DMX line does not influence the DMX addressing. For example; a fixture assigned to a DMX address of 1 may be placed anywhere in a DMX line, at the beginning, at the end, or anywhere in the middle. When a fixture is assigned a DMX address of 1, the DMX controller knows to send DATA assigned to address 1 to that unit, no matter where it is located in the DMX chain.

DATA cable (DMX cable) requirements (for DMX operation):

This fixture can be controlled via DMX-512 protocol. The DMX address is set on the back of the unit. Your unit requires either a standard 3-pin or 5-pin XLR connector for data input/output, see images below.



Further DMX cables can be purchased from all good sound and lighting suppliers or Prolight Concepts dealers.

Please quote:	3-Pin:	CABL10 – 2m	CABL11 – 5m	CABL12 – 10m
	5-Pin:	CABL185 – 2m	CABL187 – 5m	CABL188 – 10m

Also remember that DMX cable must be daisy chained and cannot be split.

Notice:

Be sure to follow the diagrams below when making your own cables. Do not connect the cables shield conductor to the ground lug or allow the shield conductor to come in contact with the XLRs outer casing. Grounding the shield could cause a short circuit and erratic behaviour.

Pin Configuration	
3-Pin	5-Pin
	Pin 1 - Ground
	Pin 2 - Negative
	Pin 3 - Positive
-	Pin 4 - N/C
-	Pin 5 - N/C

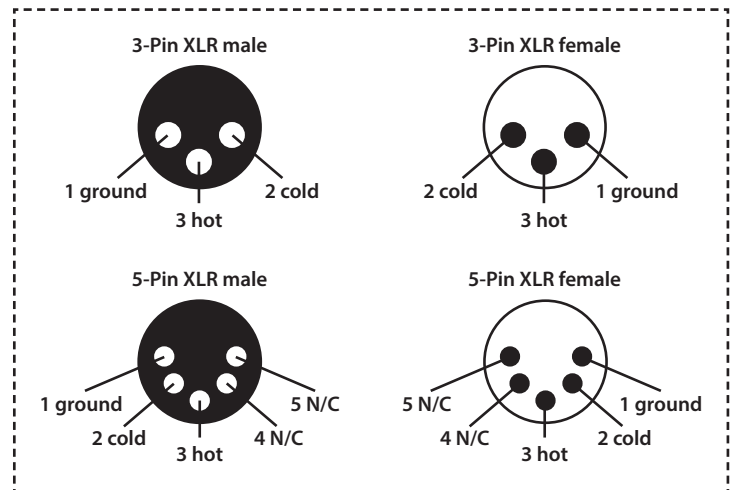
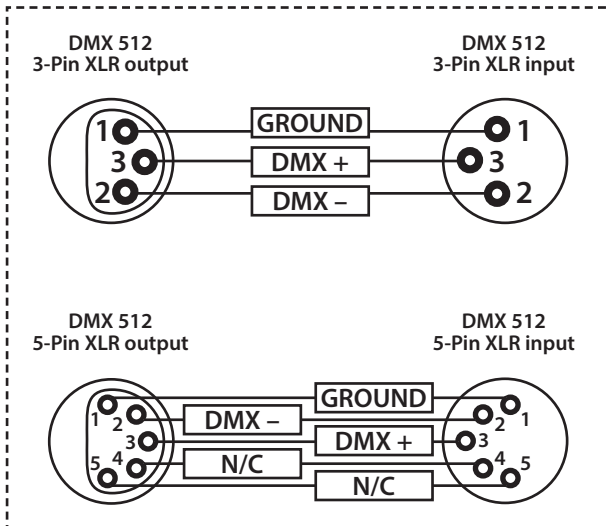

Line termination:

When longer runs of cable are used, you may need to use a terminator on the last unit to avoid erratic behaviour.

Using a cable terminator will decrease the possibilities of erratic behaviour.

(3-pin - Order ref: CABL90,
5-pin - Order ref: CABL89)

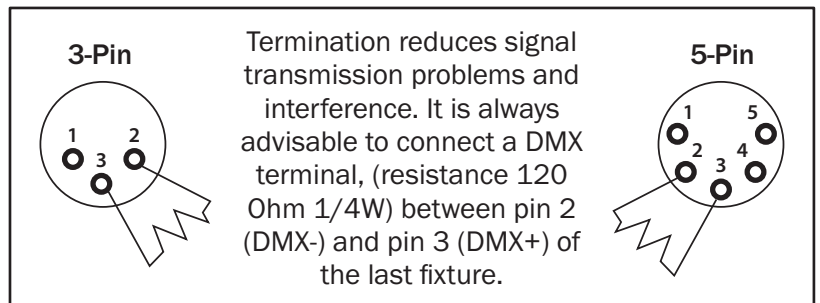

5-pin XLR DMX connectors:

Some manufactures use 5-pin XLR connectors for data transmission in place of 3-pin. 5-pin XLR fixtures may be implemented in a 3-pin XLR DMX line. When inserting standard 5-pin XLR connectors in to a 3-pin line a cable adaptor must be used. The diagram below details the correct cable conversion.

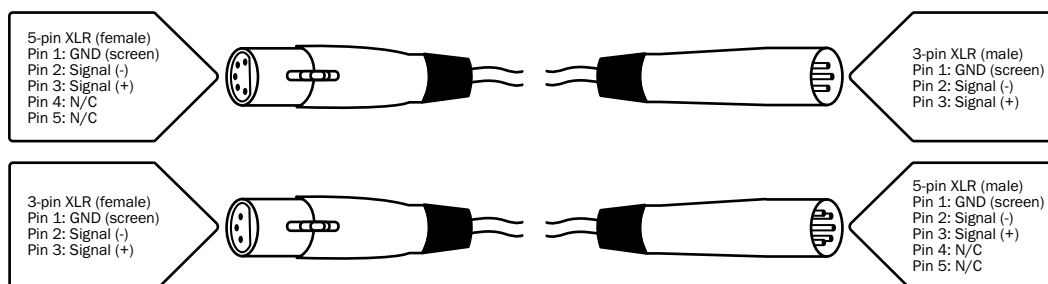

Power linking:

This fixture provides power linking via the power output on the rear allowing multiple units to be connected together. The maximum number of fixtures that can be connected via a 13A mains input is 4 fixtures @ 240V or 2 fixtures @ 120V (including the first fixture). After the maximum number of fixtures are connected a new power run will need to be started.

Please note: Caution should be used when power linking other fixtures to the Evora 200 Hybrid as the power consumption of other fixtures will vary. Fixtures fitted with lamps often require 2/3 times more current on startup, these may require their own power source.

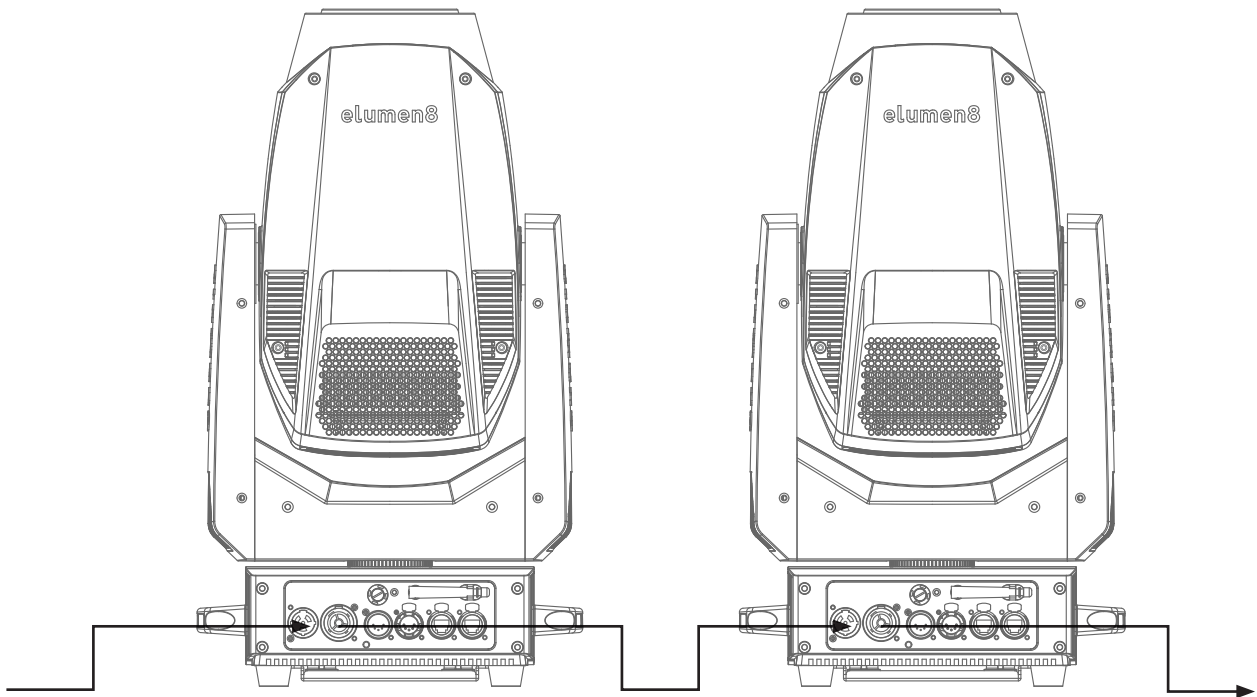



***Correct Disposal of this Product
(Waste Electrical & Electronic Equipment)***

**(Applicable in the European Union and other European countries
with separate collection systems)**

This marking shown on the product or its literature, indicates that it should not be disposed with other household wastes at the end of its working life. To prevent possible harm to the environment or human health from uncontrolled waste disposal, please separate this from other types of wastes and recycle it responsibly to promote the sustainable reuse of material resources.

Household users should contact either the retailer where they purchased this product, or their local government office, for details of where and how they can take this item for environmentally safe recycling.

Business users should contact their supplier and check the terms and conditions of the purchase contract. This product should not be mixed with other commercial wastes for disposal.

