

EQUIN X

ORION

order code: EQLA08



user manual

WARNING

**FOR YOUR OWN SAFETY, PLEASE READ THIS USER MANUAL CAREFULLY
BEFORE YOUR INITIAL START-UP!**

**CAUTION!**

**Keep this equipment away from rain,
moisture and liquids.**

**SAFETY INSTRUCTIONS**

Every person involved with the installation, operation & maintenance of this equipment should:

- Be competent
- Follow the instructions of this manual



**CAUTION! TAKE CARE USING THIS EQUIPMENT!
HIGH VOLTAGE-RISK OF ELECTRIC SHOCK!!**



Before your initial start-up, please make sure that there is no damage caused during transportation. Should there be any, consult your dealer and do not use the equipment.

To maintain the equipment in good working condition and to ensure safe operation, it is necessary for the user to follow the safety instructions and warning notes written in this manual.

Please note that damages caused by user modifications to this equipment are not subject to warranty.

IMPORTANT:

The manufacturer will not accept liability for any resulting damages caused by the non-observance of this manual or any unauthorised modification to the equipment.

- Never let the power-cable come into contact with other cables. Handle the power-cable and all mains voltage connections with particular caution!
- Never remove warning or informative labels from the equipment.
- Do not open the equipment and do not modify the equipment.
- Do not connect this equipment to a dimmer-pack.
- Do not switch the equipment on and off in short intervals, as this will reduce the system's life.
- Only use the equipment indoors.
- Do not expose to flammable sources, liquids or gases.
- Always disconnect the power from the mains when equipment is not in use or before cleaning! Only handle the power-cable by the plug. Never pull out the plug by pulling the power-cable.
- Make sure that the available voltage is between 220v/240v.
- Make sure that the power-cable is never crimped or damaged. Check the equipment and the power-cable periodically.
- If the equipment is dropped or damaged, disconnect the mains power supply immediately. Have a qualified engineer inspect the equipment before operating again.
- If the equipment has been exposed to drastic temperature fluctuation (e.g. after transportation), do not switch it on immediately. The arising condensation might damage the equipment. Leave the equipment switched off until it has reached room temperature.
- If your product fails to function correctly, discontinue use immediately. Pack the unit securely (preferably in the original packing material), and return it to your Prolight dealer for service.
- Only use fuses of same type and rating.
- Repairs, servicing and power connection must only be carried out by a qualified technician. **THIS UNIT CONTAINS NO USER SERVICEABLE PARTS.**
- **WARRANTY;** One year from date of purchase.

OPERATING DETERMINATIONS

If this equipment is operated in any other way, than those described in this manual, the product may suffer damage and the warranty becomes void.

Incorrect operation may lead to danger e.g.: short-circuit, burns, electric shocks, lamp failure etc.

Do not endanger your own safety and the safety of others!
Incorrect installation or use can cause serious damage to people and property.

You should find inside the Laser carton the following items:

- 1, Orion Laser 2, Power cable 3, Instruction manual

Technical Specifications:

Voltage: 240V AC 50Hz

Laser diode: 1 x 30mW Green (532nm) DPSS laser

Operating modes: 1, Stand Alone Sound Activated
2, Stand Alone Auto programme

Features:

Green geometric patterns ideal for use with smoke machines to produce dynamic tunnels, circles and flat lines etc.

Easy plug and play operation.

For Sound activation turn up the sensitivity control until the unit responds to the music.

For Auto programme change turn up the sensitivity control to the maximum.

Back view:

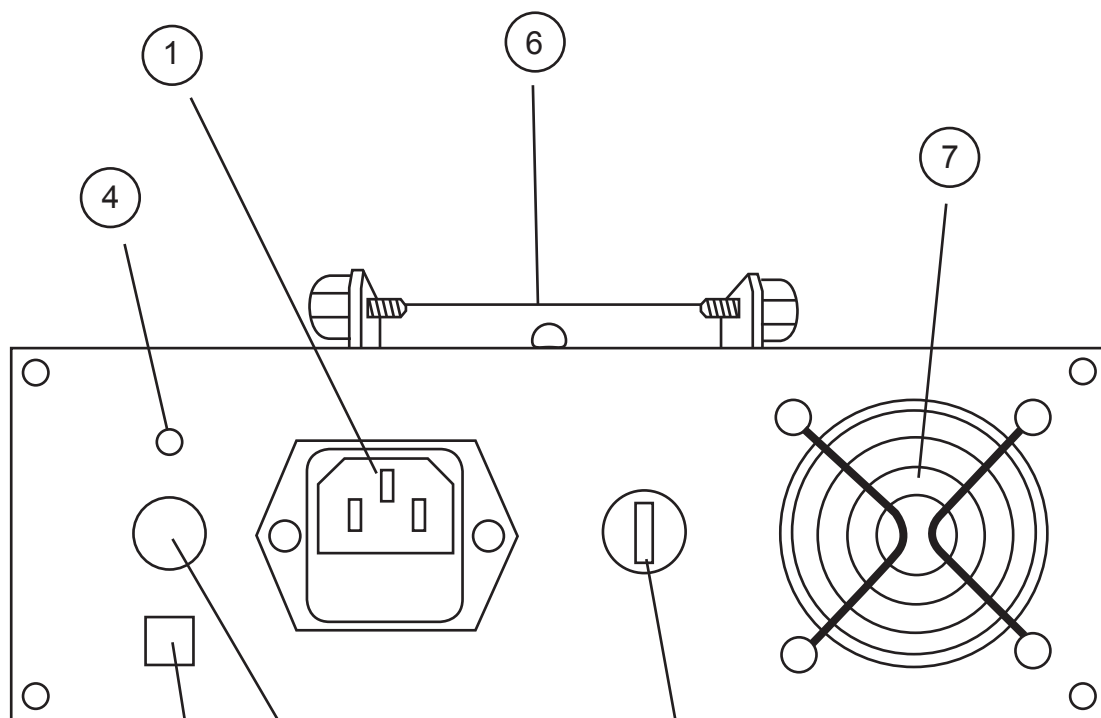

Identification:

- 1, Power input
2, Power switch
3, Microphone
4, LED power indicator
5, Sensitivity control
6, Hanging bracket
7, Cooling fan

Class 3B Laser Safety Guide

Warning

Class 3B Lasers have the potential to harm eyesight if viewed directly and can also be harmful at long distances.

Any unit that contains a laser diode has to be classified depending upon the light output that someone may be exposed to. All laser products are classed as defined in the *Laser Product Safety Standard (BS/EN 60825.1)*. The classes range from the safest, which is *Class 1*, through to the most hazardous, which is *Class 4*. A laser diode that emits more than *5mW* of light and less than *500mW* can be classified as a *Class 3B* product.

Operation and installation Notes

Laser effects should only be installed and operated by persons who have been trained in how to operate laser effects safely.

Laser effects should be located in a safe and secure position in the venue, so that once installed it cannot be tampered with by unauthorized users.

Before operation the path of the laser beams should be taken into account in respect to how the beams will scan the viewing audience.

If direct audience scanning is to be used then the laser energy levels from the effects needs to be calculated.

Health

If used responsibly and in accordance with the relevant guidance issued by the Health and Safety Executive a laser effect will not present a hazard to those viewing the show as long as the laser beams are projected over the heads of the viewing audience. When laser effects are directed into the audience area it becomes difficult to tell if the effects are causing harm.

Class 3B laser beams can be harmful to eyesight if viewed directly. The injury that a Class 3B laser can inflict is dependant upon several varients, including the amount of time the laser beam enters the eye for, the intensity of beam and what part of the eye that actually receives the beam. The part of the eye which is most susceptible to receive damage from the beam is the retina. The retina is the part of the eye that receives the light signals that are sent to brain. All light entering the eye gets focused onto the retina.

Normal light sources including halogen lamps are not usually harmful to view. Lasers are different in the fact that they can get the beam focused down to a very small point on the retina which can burn holes on the back wall of the eye. There are no pain receptors on the retina and the damage can happen in less time than it takes for a person to blink so the person will be not be aware of any damage taking place. Damage to the retina cannot be repaired and therefore is permanent. Symptoms include severe loss of sight and unnoticeable vision loss.

Licensing and Laws

There are no U.K. “laser laws” or any “laser licenses” that need to be obtained in order to own or operate a laser for lightshow use. Detailed and specific guidance is issued by the Health and Safety Executive in the form of a book called HS(G)95 The Radiation Safety of Lasers Used for Display Purposes.

Class 3B Laser Safety Features

Class 3B laser products need to be fitted with specific safety features. These features are issued in the British Standard on Laser Product Safety

BS/EN 60825-1 and are needed for the product to meet CE approval.

The important warnings are listed below:-

- 1) Emissions Indicator
- 2) Remote Interlock Connector
- 3) Laser Safety Warning Labels

Summary of each Feature

Class 3B lasers need to contain three very important Laser Safety Warning Labels; the starburst symbol, aperture label, and the warning/classification label. The starburst is used to indicate that the product is a laser product. The aperture label is located next to the aperture to show where the laser emits its beam(s). The warning/classification label details the class of the laser product, the maximum output power, and the wavelength(s) (colours) of the laser, along with a “Laser Radiation – Avoid Exposure To The Beam” warning

The Remote Interlock Connector will only allow the laser to function when the two pins are shorted together. For lightshow use it is recommended by HS(G)95 laser safety guidance laser effects can be overridden by a remote Emergency Stop switch. The remote interlock connector provides a convenient way for such a switch to be easily added to the laser system, to provide this control.

The emissions indicator is fitted to indicate when the laser is ready to produce a light output.

Audience Scanning

Audience Scanning is when laser beams are directed at the viewing audience. Because the laser output beam can scan people’s faces it carries a risk that it could cause damage to eyesight, if over exposed to the laser beam.

Maximum Permissible Exposure (MPE)

The amount of laser light that a person can be exposed to without it causing harm to eyesight is known as the Maximum Permissible Exposure or MPE. These levels are set down by the British Laser Safety Standard BS/EN 60826-1. When people are exposed to laser light output which is above the MPE, it may potentially pose a risk of causing eye damage. Calculating what the MPE and exposure level is for a given laser effect is quite a complicated process and it is dependant on a whole number of factors and conditions. The laser safety standard BS/EN 60825-1 contains the information and data required to calculate these levels.

Laser Safety Officer

The BS/EN60825-1 Laser Safety Standard recommends that all venues that use, or businesses that work with Class 3B laser products, should appoint a Laser Safety Officer (LSO). The Laser Safety Officer should be aware of the many safety issues when using lasers, and will also be responsible for overseeing how the laser is used. In smaller businesses, the (LSO) could be the installer, operator or owner etc.

Separation Distances

Health and Safety guidance details that for supervised installations of lasers which are above the Maximum Permissible Exposure (MPE) should not be accessible to persons in the audience. Also recommended is an area where the MPE may not be exceeded and extends from 3m above to 2.5m laterally from any point in the venue where the public may have access during the lightshow. The illustrations below show the separation distances.

Separation Distance Drawing:

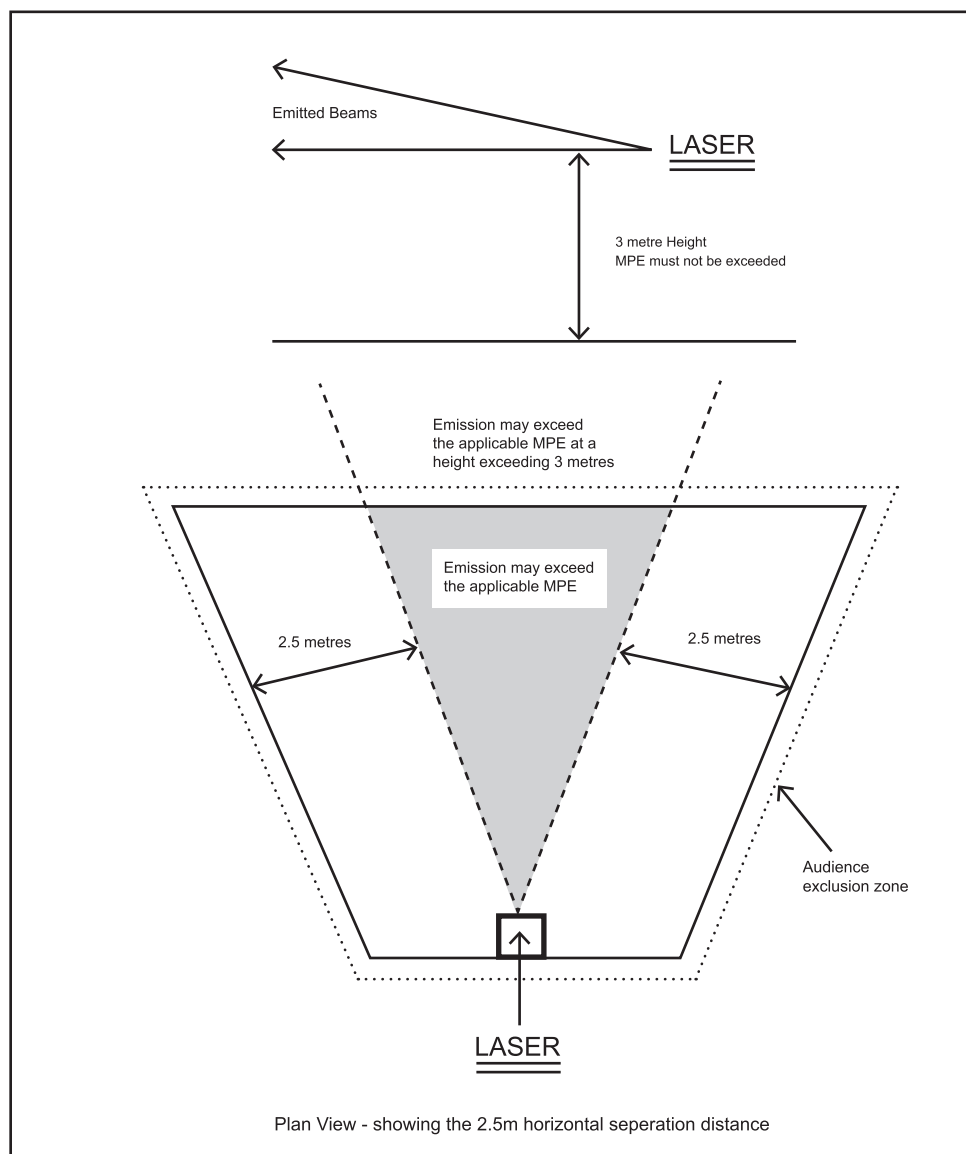

Note. The 3 metre height specified is not the height of the actual laser unit, but it refers to the height of the laser beams emitted.

Hazard Distances

All lasers for display purposes feature a characteristic called the hazard distance for direct viewing (NOHD). The (NOHD) is distance at which viewing the laser directly is no longer considered a hazard. Note at any point between the laser unit and the calculated hazard distance, it may be hazardous to directly view the laser beams. Exposing the eye to the laser directly from outside the hazard distance is considered to be no longer a risk.

The most dangerous senerio is to look directly at a static single beam, because all the light energy is concentrated into one small point. The hazard distances for various different powers of Class 3B laser are shown in the table below.

Laser Output Power	10mW	30mW	50mW	100mW	250mW	450mW
Hazard Distance	12m	20m	25m	36m	56m	76m

Note - The above values in the table have been calculated assuming the characteristics of a typical laser, which has a beam spread of 2mradians. Not all laser units have the same specification.

Remember: Static laser beams are hazardous for long distances so it is recommended that the laser beams are projected overhead and not into the viewing audience

Laser Safety Books

The Radiation Safety of Display Laser Installations HS(G)95
Published by HSE Books 1996 ISBN 0 7176 0691

Health & Safety Executive
Website - www.hse.gov.uk

Laser display safety guidance page - www.hse.gov.uk/pubns/INDG224.htm

Health Protection Agency
Website - www.hpa.org.uk