

EQUINOX

Fusion 300FX Zoom Wash User Manual



Order codes: EQLED077

WARNING

FOR YOUR OWN SAFETY, PLEASE READ THIS USER MANUAL CAREFULLY BEFORE YOUR INITIAL START-UP!

- Before your initial start-up, please make sure that there is no damage caused during transportation.
- Should there be any damage, consult your dealer and do not use the equipment.
- To maintain the equipment in good working condition and to ensure safe operation, it is necessary for the user to follow the safety instructions and warning notes written in this manual.
- Please note that damages caused by user modifications to this equipment are not subject to warranty.



IMPORTANT:

The manufacturer will not accept liability for any resulting damages caused by the non-observance of this manual or any unauthorised modification to the equipment.

- Never let the power cable come into contact with other cables. Handle the power cable and all mains voltage connections with particular caution!
- Never remove warning or informative labels from the unit.
- Do not open the equipment and do not modify the unit.
- Do not connect this equipment to a dimmer pack.
- Do not switch the equipment on and off in short intervals, as this will reduce the system's life.
- Only use the equipment indoors.
- Do not expose to flammable sources, liquids or gases.
- Always disconnect the power from the mains when equipment is not in use or before cleaning! Only handle the power-cable by the plug. Never pull out the plug by pulling the power-cable.
- Make sure that the available mains supply voltage is between 100~240V AC, 50/60Hz.
- Make sure that the power cable is never crimped or damaged. Check the equipment and the power cable periodically.
- If the equipment has been exposed to drastic temperature fluctuation (e.g. after transportation), do not connect power or switch it on immediately. The arising condensation might damage the equipment. Leave the equipment switched off until it has reached room temperature.
- Never touch the fixture during operation as it may be hot.
- If the equipment is dropped or damaged, disconnect the mains power supply immediately and have a qualified engineer inspect the equipment before operating again.
- If your product fails to function correctly, stop use immediately. Pack the unit securely (preferably in the original packing material), and return it to your Pro Light dealer for service.
- Only use fuses of same type and rating.
- Repairs, servicing and power connection must only be carried out by a qualified technician. THIS UNIT CONTAINS NO USER SERVICEABLE PARTS.
- This lighting fixture is for professional use only - it is not designed for or suitable for household use. The product must be installed by a qualified technician in accordance with local territory regulations. The safety of the installation is the responsibility of the installer. The fixture presents risks of severe injury or death due to fire hazards, electric shock and falls.
- Warning! Risk Group 2 LED product according to EN 62471. Do not view the light output with optical instruments or any device that may concentrate the beam.
- WARRANTY: One year from date of purchase.

OPERATING DETERMINATIONS

If this equipment is operated in any other way, than those described in this manual, the product may suffer damage and the warranty becomes void. Incorrect operation may lead to danger e.g: short-circuit, burns and electric shocks etc.

Do not endanger your own safety and the safety of others!

Incorrect installation or use can cause serious damage to people and/or property.

Please note: These fixtures are intended for stage lighting and entertainment applications only, and are not intended for extended periods of use, including but not limited to house-light, industrial or architectural applications and should only be operated with short duty cycles.

This fixture falls under Protection Class 1, therefore it has to be connected to a mains socket with a protective earthing connection.

Risk group 2, RG-2: CAUTION!
Do not stare at exposed LED in operation as it may damage/be harmful to the eyes. Avoid looking directly into the light source.

CAUTION!
The maximum ambient temperature (T_a) of 40° must not be exceeded.

CAUTION!
If the lens gets damaged ie. cracks or deep scratches so the output is impaired then it must be replaced.

Fusion 300FX Zoom Wash

The compact Fusion 300FX Zoom Wash features 7 x 40W quad-colour LEDs (RGBW) outputting gentle pastel tones to rich saturated hues. The motorised zoom from a narrow 5 degree beam angle to a wider 40 degree paired with front-lens rotation, allows the user to create superb mid-air beam effects along with wide washes of colour. The fixture also features colour temperature presets, DMX, auto, sound active, manual control and master/slave modes all accessible via the onboard 4 button menu.

- 7 x 40W quad-colour LEDs (RGBW)
- Adjustable beam angle: 5° - 40°
- 5° - 86,570 Lux @ 2m (full on),
40° - 6,156 Lux @ 2m (full on)
- CRI: 70
- 3kHz refresh rate
- Motorised zoom
- Front lens rotation
- DMX channels: 2/10/14 or 17 selectable
- Auto, sound active, manual control and master/slave modes
- Colour temperature presets
- Forward facing show mode
- Pan/tilt auto correction
- 16-Bit pan/tilt positioning
- Pan: 540°, Tilt: 270°
- 0 - 100% dimming
- Variable strobe
- Quick release omega clamps included
- Square hole spacing on omega clamp receivers allows for clamps to be mounted in all orientations
- 4 button menu with 2.6" LCD display
- PowerTwist input/output
- 3-Pin XLR input/output
- Fan cooled



5° - Lux					
FULL ON	346280	86570	38475	21642	13851
R	49296	12324	5477	3081	1971
G	150600	37650	16733	9412	6024
B	21620	5405	2402	1351	864
W	190224	47556	21136	11889	7608
40° - Lux					
FULL ON	24624	6156	2736	1539	985
R	3212	803	357	201	128
G	10284	2571	1143	643	411
B	2316	579	257	145	93
W	12904	3226	1433	806	516

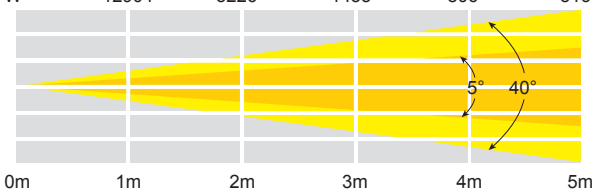

Specifications	Fusion 300FX Zoom Wash
Power consumption	300W
Power supply	100~240V, 50/60Hz
Fuse	F4A 250V
Dimensions	395 x 310 x 185mm
Weight	8.7kg
Order code	EQLED077

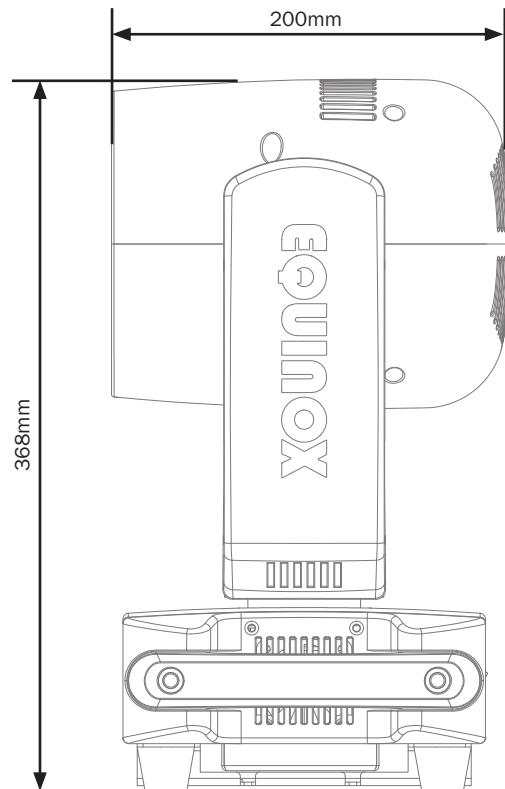
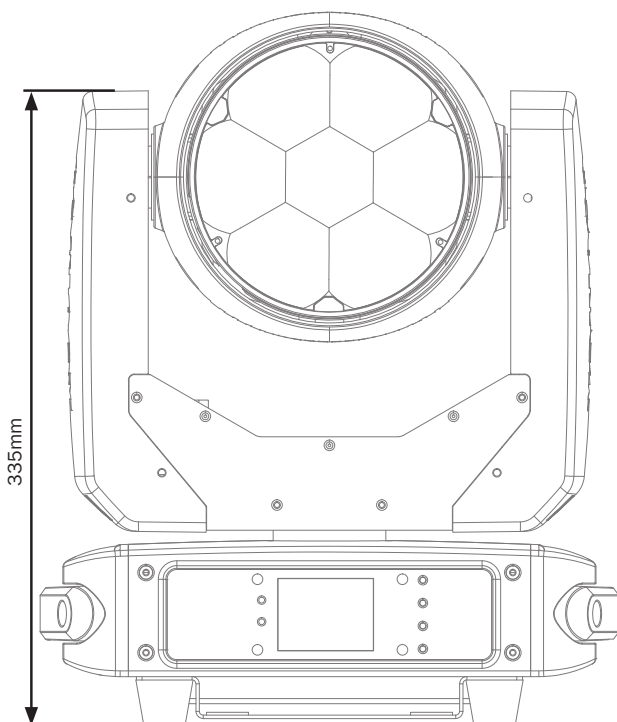
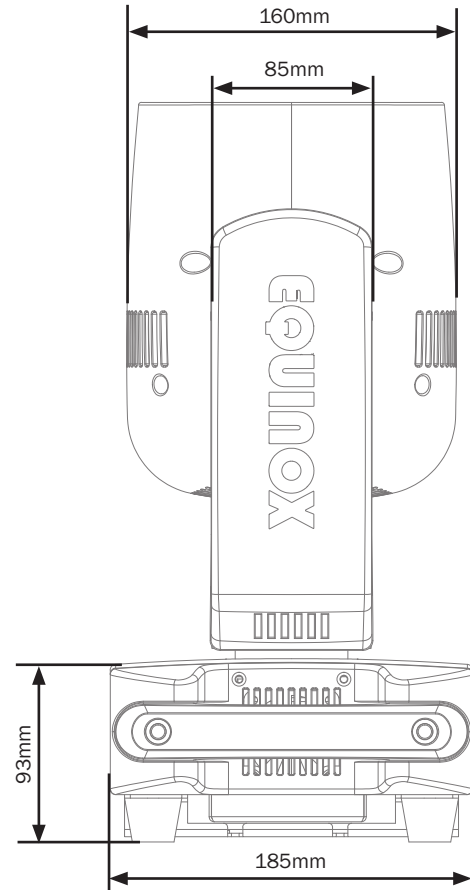
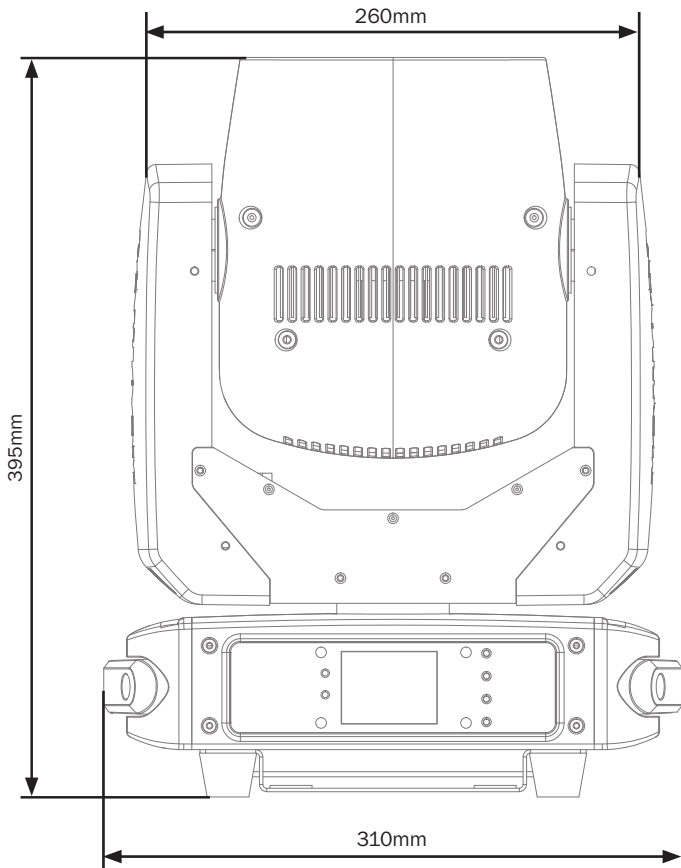

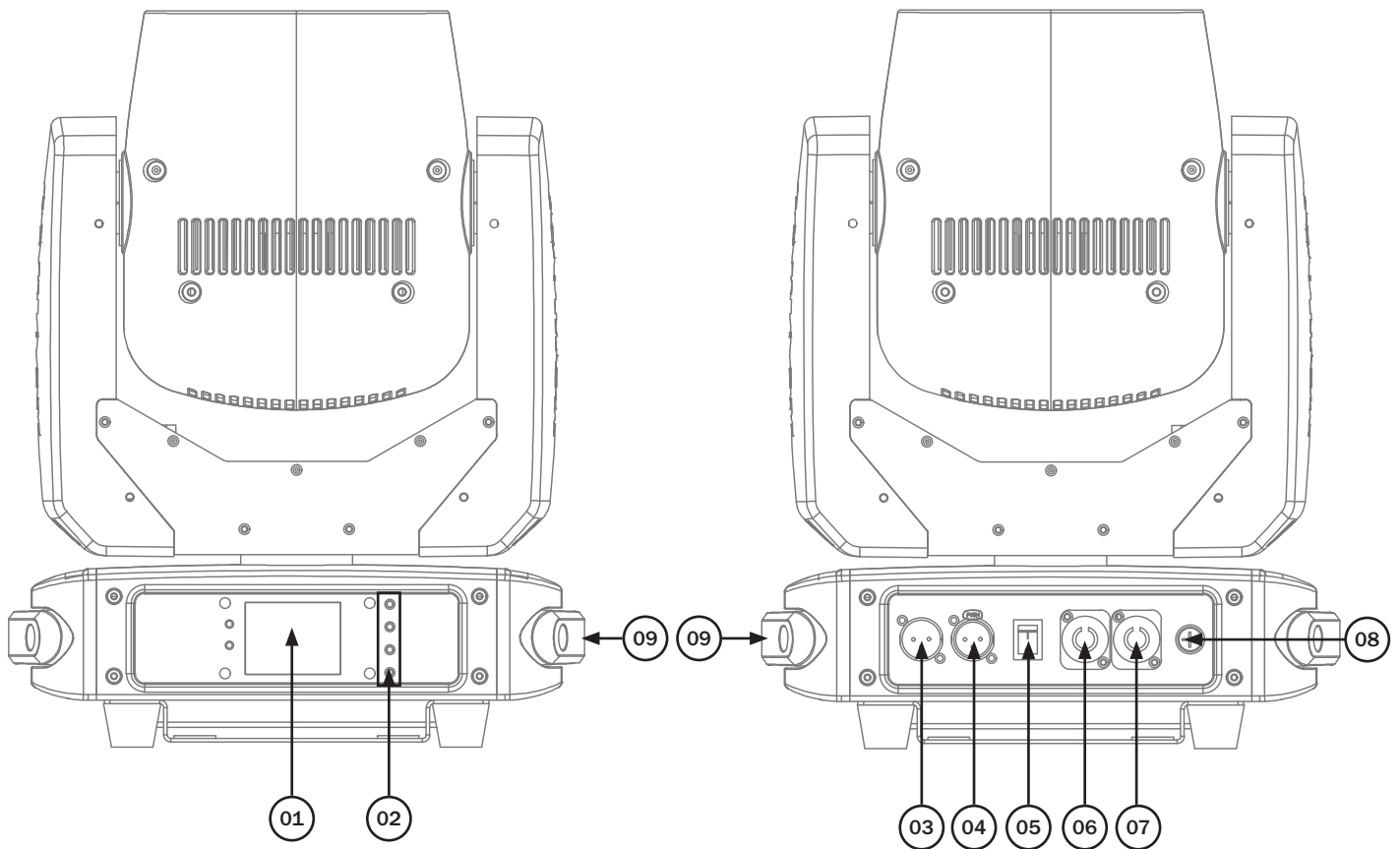

01 - LCD display
 02 - Function buttons
 03 - 3-Pin XLR input

04 - 3-Pin XLR output
 05 - Power switch
 06 - PowerTwist input

07 - PowerTwist output
 08 - Fuse F4A 250V
 09 - Carry handles

In the box: **1 x fixture,**
2 x omega clamps,
& 1 x power cable

Before installing the fixture, the supporting structure (ie. truss) must be able to hold a minimum of 10 times the fixtures weight without any deformation (eg. 15kg - 150kg point load). The fixture must be secured with a secondary safety attachment when being installed (ie. an appropriate safety cable). Never stand directly below the fixture when mounting, removing, and/or servicing.

Overhead installation requires experience and qualifications to calculate working load limits, the material being used at the installation area and periodic safety inspections of the fixture and installation material. If you do not have the relevant experience and/or qualifications please do not attempt the installation yourself. The installation should be checked annually by a qualified person.

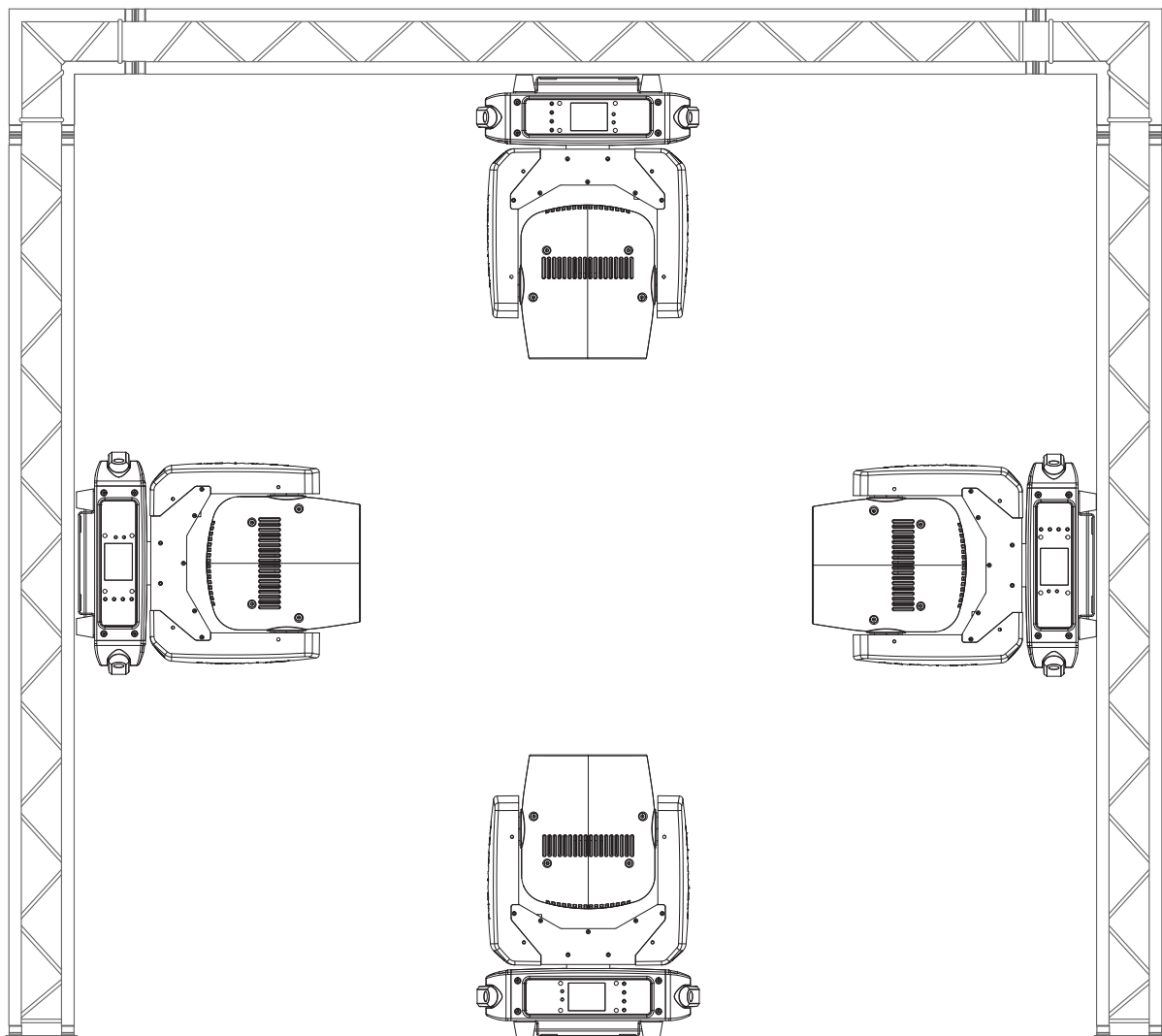

The Equinox Fusion 300FX Zoom Wash can be operated in a number of mounting positions as shown in the diagram above, hanging upside-down from the ceiling or truss, mounting sideways on truss or stood upright on a flat level surface. Always use a safety wire as an extra safety precaution to prevent damage/injury in the event a clamp fails (see the next page for clamp installation). Never use the carry handles for secondary attachments.

Installation:

1. Fasten each clamp to the omega clamps with a bolt and lock nut through the hole in the omega clamp.
2. Align and insert the omega clamp quick-lock fasteners with the respective holes on the bottom of the unit.
3. Tighten both locking fasteners clockwise on each omega clamp ensuring they're fully secure.
4. Mount the fixture onto your truss system via the clamps and tighten to ensure secure.
5. Pull the safety cable through the safety cable holes located on the metal base plate on the underside of the fixture and around the truss.

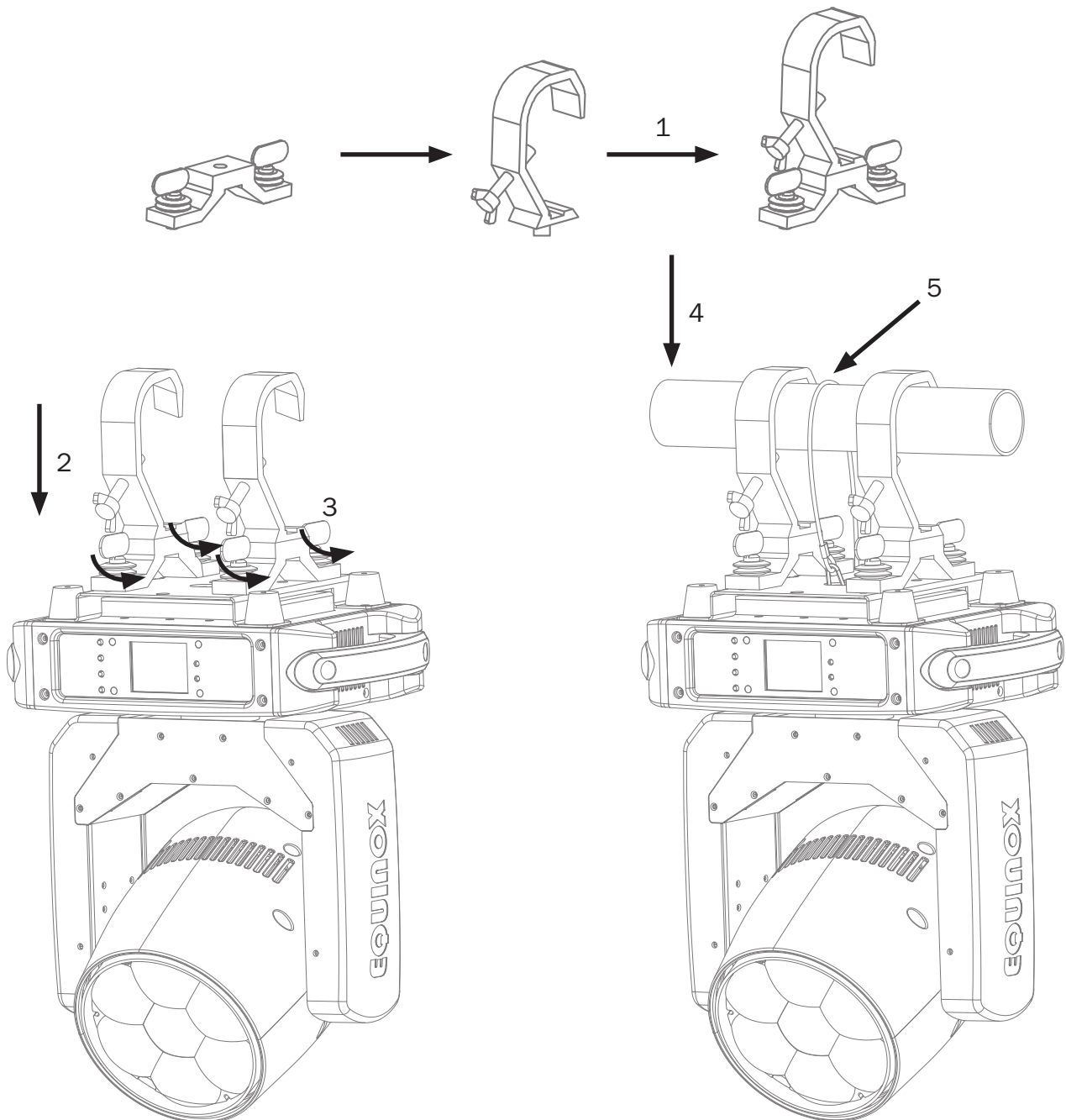

Control Panel Menu:

The LCD control panel situated on the front of the fixture allows the user to access the menu system to adjust the fixtures settings.

When the unit has been powered on the display will show “**Equinox Fusion 300FX Zoom Wash**”, “**Motor Reset... Please Wait...**” whilst the unit performs its motor reset.

The fixture will then return to its home screen.

Pressing the “**MENU**” button once will take the user to the fixtures main menu. Using the “**UP**” and “**DOWN**” buttons you can then navigate between the different options in the main menu. Pressing the “**ENTER**” button on one of these options allows you to access the sub menu where you can use the “**UP**” and “**DOWN**” buttons to select option/value required. Once the option/value has been selected press the “**ENTER**” button once more to confirm the setting.

To exit out of any of the above options, press the “**MENU**” button.

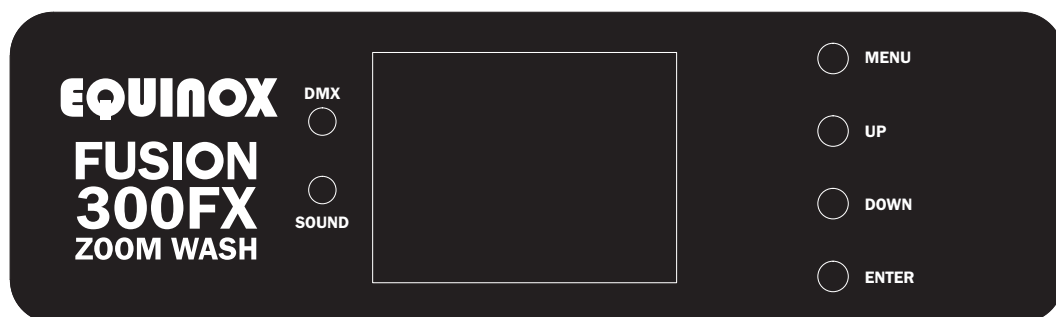

Main Menu - Defaults are in grey

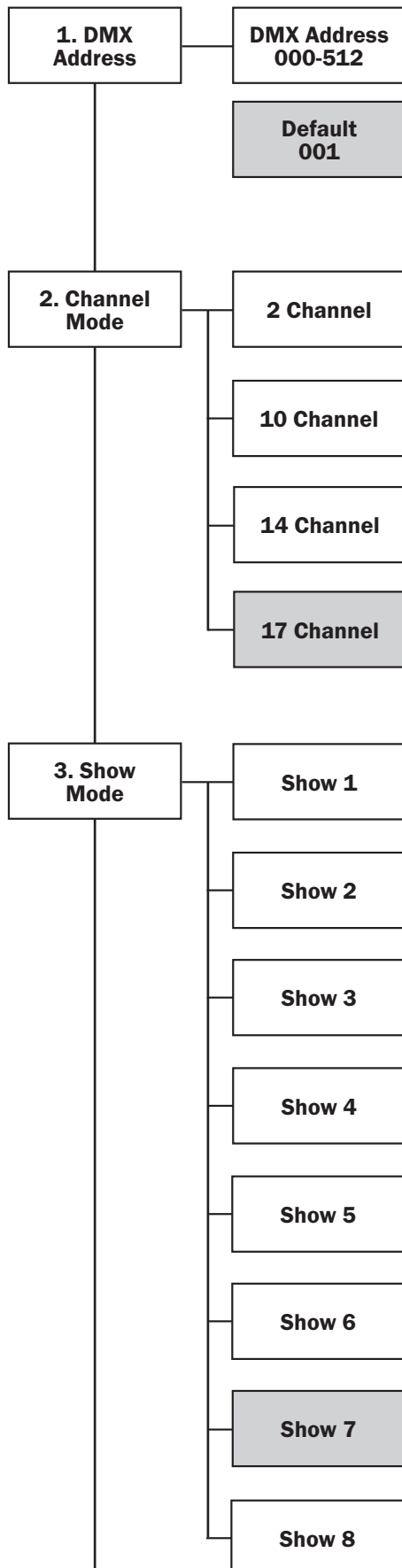

DMX address:

To access the DMX address mode, press the “ENTER” button and use the “UP” and “DOWN” buttons to show “DMX Address” on the LCD display. Now press the “ENTER” button and use the “UP” and “DOWN” buttons to set the required DMX address. Press the “ENTER” button to confirm the setting.

DMX channel mode:

To access the DMX channel mode, press the “ENTER” button and use the “UP” and “DOWN” buttons to show “Channel Mode” on the LCD display. Now press the “ENTER” button and use the “UP” and “DOWN” buttons to set the required DMX channel. Press the “ENTER” button to confirm the setting.

Show mode:

To access the show modes, press the “ENTER” button and use the “UP” and “DOWN” buttons to show “Show Mode” on the LCD display. Now press the “ENTER” button and use the “UP” and “DOWN” buttons to set the required show mode. Press the “ENTER” button to confirm the setting. Show 7 and 8 are forward facing show modes.

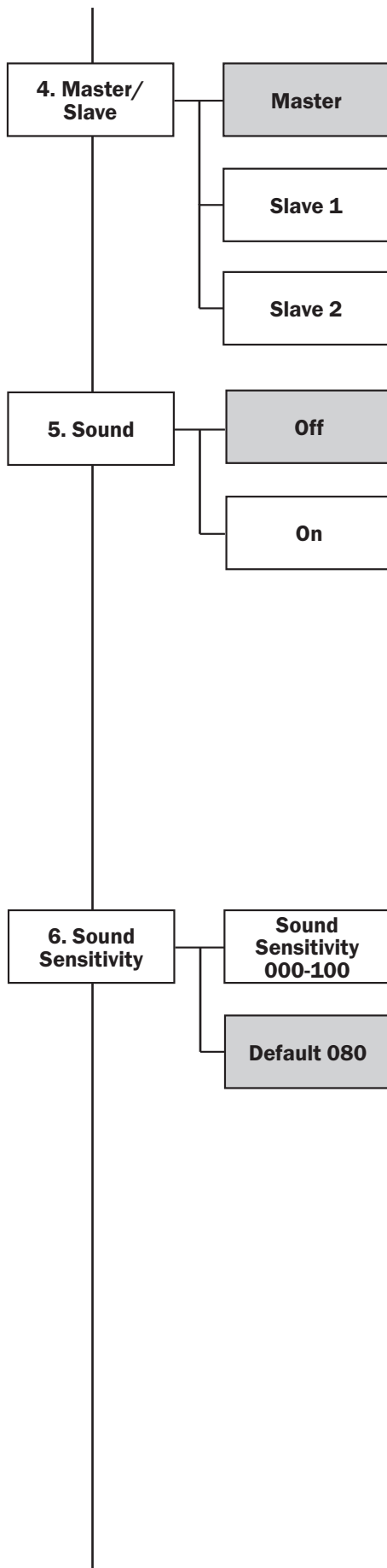

Master/slave mode:

To access the master/slave modes, press the “ENTER” button and use the “UP” and “DOWN” buttons to show “Master/Slave” on the LCD display. Now press the “ENTER” button and use the “UP” and “DOWN” buttons to set the required mode. Press the “ENTER” button to confirm the setting.

Sound mode:

To access the sound mode setting, press the “ENTER” button and use the “UP” and “DOWN” buttons to show “Sound” on the LCD display. Now press the “ENTER” button and use the “UP” and “DOWN” buttons to select between “ON” and “OFF”. Press the “ENTER” button to confirm the setting.

*Once sound mode is set to “ON” in the secondary unit please then go and select the same show mode as set on the primary unit.

Sound sensitivity:

To access the sound sensitivity setting, press the “ENTER” button and use the “UP” and “DOWN” buttons to show “Sound Sensitivity” on the LCD display. Now press the “ENTER” button and use the “UP” and “DOWN” buttons to select between “000” and “100”. Press the “ENTER” button to confirm the setting.

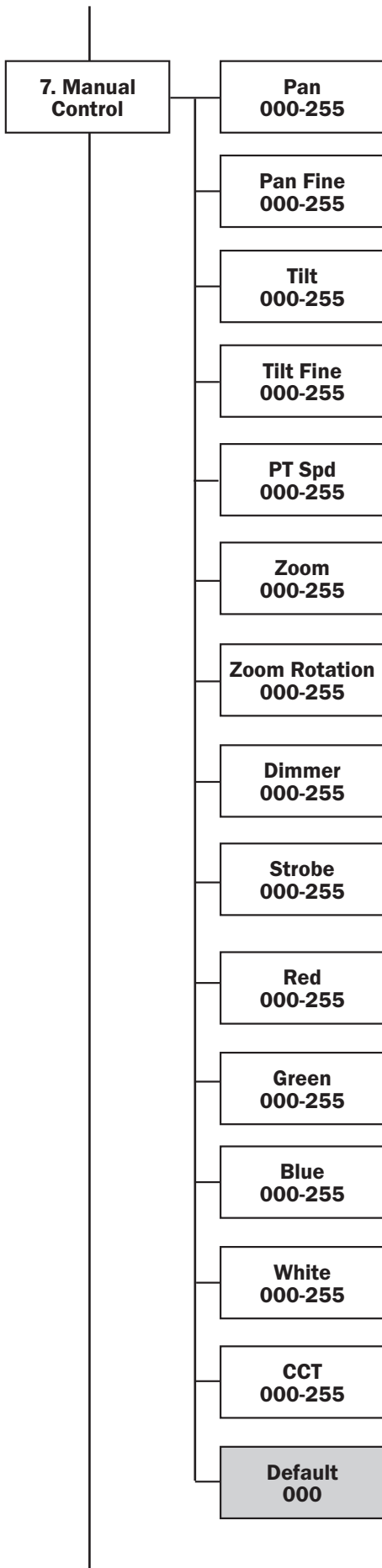

Manual control:

To access manual control mode, press the “ENTER” button and use the “UP” and “DOWN” buttons to show “Manual Control” on the LCD display. Press the “ENTER” button and use the “UP” and “DOWN” buttons to select the various options. Press the “ENTER” button and use the “UP” and “DOWN” buttons to select between “000” - “255”. Press the “ENTER” button to confirm the setting.

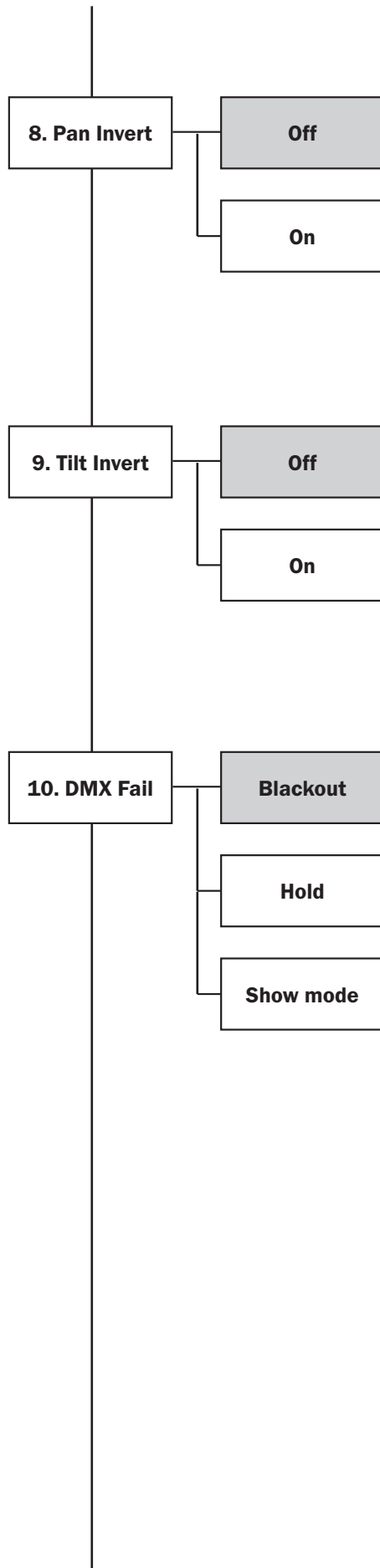

Pan invert:

To access the pan invert setting, press the “ENTER” button and use the “UP” and “DOWN” buttons to show “Pan Invert” on the LCD display. Press the “ENTER” button and use the “UP” and “DOWN” buttons to select between “No” and “Yes”. Press the “ENTER” button to confirm the setting.

Tilt invert:

To access the tilt invert setting, press the “ENTER” button and use the “UP” and “DOWN” buttons to show “Tilt Invert” on the LCD display. Press the “ENTER” button and use the “UP” and “DOWN” buttons to select between “No” and “Yes”. Press the “ENTER” button to confirm the setting.

DMX fail:

Sets what the fixture does when the DMX signal is lost. To access the DMX fail setting, press the “ENTER” button and use the “UP” and “DOWN” buttons to show “DMX Fail” on the LCD display. Now press the “ENTER” button and use the “UP” and “DOWN” buttons to choose between “Blackout”, “Hold” or “Show mode”. Press the “ENTER” button to confirm the setting.



Display backlight:

To access the display backlight setting, press the “ENTER” button and use the “UP” and “DOWN” buttons to show “Display Settings” on the LCD display. Press the “ENTER” button and use the “UP” and “DOWN” buttons to select “Backlight”. Press the “ENTER” button and use the “UP” and “DOWN” buttons to select between “Off” and “On”. Press the “ENTER” button to confirm the setting.

Display invert:

To access the display invert setting, press the “ENTER” button and use the “UP” and “DOWN” buttons to show “Display Settings” on the LCD display. Press the “ENTER” button and use the “UP” and “DOWN” buttons to select “Invert”. Press the “ENTER” button and use the “UP” and “DOWN” buttons to select between “On”, “Off” and “Auto”. Press the “ENTER” button to confirm the setting.

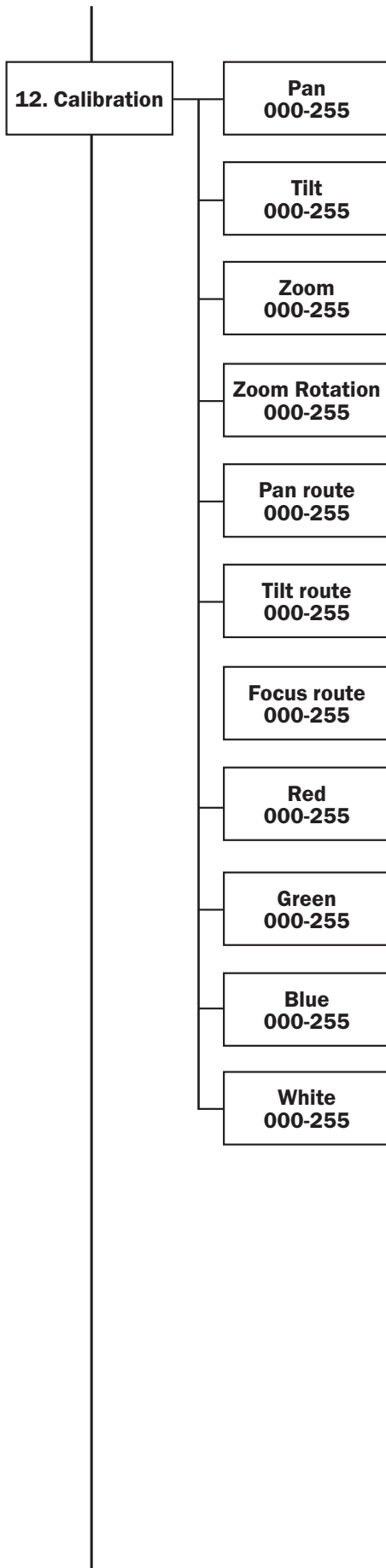

Calibration:

Calibration settings for the fixture.

To access the units calibration menu press the “ENTER” button and use the “UP” and “DOWN” buttons to show “Calibration”. Press the “ENTER” button and use the “UP” and “DOWN” buttons to select the various options. Press the “ENTER” button and use the “UP” and “DOWN” buttons to select between “000” - “255”.

Press the “ENTER” button to confirm the setting.

Please note: Calibration settings are set when the fixture is manufactured. This can be changed manually for home position adjustment.

Performing a factory reset will not change these settings.

Descriptions:

Pan - Pan Fine Adjustment

Tilt - Tilt Fine Adjustment

P/T Speed - Pan/Tilt Speed Adjustment

Zoom - Zoom Fine Adjustment

Zoom rotation - Zoom Rotation Fine Adjustment

Pan limit - Pan Start/End Point Adjustment

Tilt limit - Tilt Start/End Point Adjustment

Focus Limit - Focus Start/End Point Adjustment

Red - Red Brightness Adjustment

Green - Green Brightness Adjustment

Blue - Blue Brightness Adjustment

White - White Brightness Adjustment

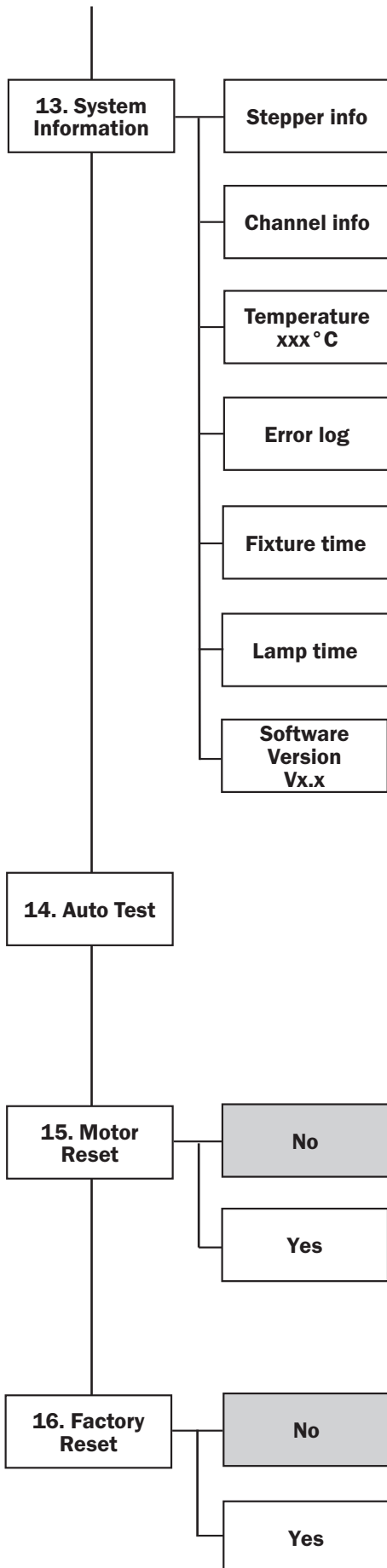

System information:

To display the fixtures system information, press the “ENTER” button and use the “UP” and “DOWN” buttons to show “System Information” on the LCD display. The unit will now display the fixtures current run time, total run time, temperature and software version.

Auto test:

Tests all functions and motors in the fixture. To access the auto test mode, press the “ENTER” button and use the “UP” and “DOWN” buttons to show “Auto Test” on the LCD display. Press the “ENTER” button and the fixture will initiate auto test.

Please note: Auto test will automatically stop when exiting the auto test menu.

Motor reset:

Resets all the fixtures motors.

To access the motor reset setting, press the “ENTER” button and use the “UP” and “DOWN” buttons to show “Motor Reset” on the LCD display. Press the “ENTER” button and use the “UP” and “DOWN” buttons to select between “Yes” and “No”. Press the “ENTER” button to perform the motor reset when yes is selected.

Factory Reset:

Resets all the fixtures factory settings.

To access the factory setting reset, press the “ENTER” button and use the “UP” and “DOWN” buttons to show “Factory Reset” on the LCD display. Press the “ENTER” button and use the “UP” and “DOWN” buttons to select between “Yes” and “No”. Press the “ENTER” button to perform the factory reset when yes is selected.

2 channel mode:

Channel	Value	Function
CH1	000-015	No function
	016-045	Show 1
	046-075	Show 2
	076-105	Show 3
	106-135	Show 4
	136-165	Show 5
	166-195	Show 6
	196-225	Show 7 (forward facing show)
	226-255	Show 8 (forward facing show)
CH2	000-255	Sound sensitivity (low-high)

10 channel mode:

Channel	Value	Function
CH1	000-255	Pan adjustment 0-540°
CH2	000-255	Tilt adjustment 0-270°
CH3	000-255	Zoom (narrow-wide)
CH4	000-127	Manual rotation
	128-190	Rotate CW (fast-slow)
	191-192	No function
	193-255	Rotate CCW (slow-fast)
CH5	000-255	Master dimmer (0-100%)
CH6	000-255	Red dimmer (0-100%)
CH7	000-255	Green dimmer (0-100%)
CH8	000-255	Blue dimmer (0-100%)
CH9	000-255	White dimmer (0-100%)
CH10	000	No function
	001-027	2800K
	028-055	3200K
	056-083	3600K
	084-111	4500K
	112-139	5000K
	140-167	5600K
	168-195	6200K
	196-223	6800K
	224-251	7500K
	252-255	8500K

14 channel mode:

Channel	Value	Function
CH1	000-255	Pan adjustment 0-540°
CH2	000-255	Pan fine adjustment
CH3	000-255	Tilt adjustment 0-270°
CH4	000-255	Tilt fine adjustment
CH5	000-255	Pan/tilt speed (fast-slow)
CH6	000-255	Zoom (narrow-wide)
CH7	000-127	Manual rotation
	128-190	Rotate CW (fast-slow)
	191-192	No function
	193-255	Rotate CCW (slow-fast)
CH8	023-031	Master dimmer (0-100%)
CH9	000-004	No function
	005-255	Strobe (slow-fast)
CH10	000-255	Red dimmer (0-100%)
CH11	000-255	Green dimmer (0-100%)
CH12	000-255	Blue dimmer (0-100%)
CH13	000-255	White dimmer (0-100%)
CH14	000-127	No function
	128-255	Reset (hold for 5s)

17 channel mode:

Channel	Value	Function
CH1	000-255	Pan adjustment 0-540°
CH2	000-255	Pan fine adjustment
CH3	000-255	Tilt adjustment 0-270°
CH4	000-255	Tilt fine adjustment
CH5	000-255	Pan/tilt speed (fast-slow)
CH6	000-255	Zoom (narrow-wide)
CH7	000-127	Manual rotation
	128-190	Rotate CW (fast-slow)
	191-192	No function
	193-255	Rotate CCW (slow-fast)
CH8	023-031	Master dimmer (0-100%)
CH9	000-004	No function
	005-255	Strobe (slow-fast)
CH10	000-255	Red dimmer (0-100%)
CH11	000-255	Green dimmer (0-100%)
CH12	000-255	Blue dimmer (0-100%)
CH13	000-255	White dimmer (0-100%)

17 channel mode (cont):

Channel	Value	Function
CH14	000	No function
	001-027	2800K
	028-055	3200K
	056-083	3600K
	084-111	4500K
	112-139	5000K
	140-167	5600K
	168-195	6200K
	196-223	6800K
	224-251	7500K
CH15	252-255	8500K
	000-015	No function
	016-045	Show 1
	046-075	Show 2
	076-105	Show 3
	106-135	Show 4
	136-165	Show 5
	166-195	Show 6
	196-225	Show 7 (forward facing show)
226-255	Show 8 (forward facing show)	
CH16	000-255	Sound sensitivity (low-high)
CH17	000-127	No function
	128-255	Reset (hold for 5s)

Setting the DMX address:

The DMX mode enables the use of a universal DMX controller. Each fixture requires a “start address” from 1- 512. A fixture requiring one or more channels for control begins to read the data on the channel indicated by the start address. For example, a fixture that occupies or uses 7 channels of DMX and was addressed to start on DMX channel 100, would read data from channels: 100, 101, 102, 103, 104, 105 and 106. Choose a start address so that the channels used do not overlap. E.g. the next unit in the chain starts at 107.

DMX 512:

DMX (Digital Multiplex) is a universal protocol used as a form of communication between intelligent fixtures and controllers. A DMX controller sends DMX data instructions from the controller to the fixture. DMX data is sent as serial data that travels from fixture to fixture via the DATA “IN” and DATA “OUT” XLR terminals located on all DMX fixtures (most controllers only have a data “out” terminal).

DMX linking:

DMX is a language allowing all makes and models of different manufactures to be linked together and operate from a single controller, as long as all fixtures and the controller are DMX compliant. To ensure proper DMX data transmission, when using several DMX fixtures try to use the shortest cable path possible. The order in which fixtures are connected in a DMX line does not influence the DMX addressing. For example; a fixture assigned to a DMX address of 1 may be placed anywhere in a DMX line, at the beginning, at the end, or anywhere in the middle. When a fixture is assigned a DMX address of 1, the DMX controller knows to send DATA assigned to address 1 to that unit, no matter where it is located in the DMX chain.

DATA cable (DMX cable) requirements (for DMX operation):

This fixture can be controlled via DMX-512 protocol. The DMX address is set on the back of the unit. Your unit requires either a standard 3-pin or 5-pin XLR connector for data input/output, see images below.



Further DMX cables can be purchased from all good sound and lighting suppliers or Prolight Concepts dealers.

Please quote:	3-Pin:	CABL10 - 2m	CABL11 - 5m	CABL12 - 10m
	5-Pin:	CABL185 - 2m	CABL187 - 5m	CABL188 - 10m

Also remember that DMX cable must be daisy chained and cannot be split.

Notice:

Be sure to follow the diagrams below when making your own cables. Do not connect the cables shield conductor to the ground lug or allow the shield conductor to come in contact with the XLRs outer casing. Grounding the shield could cause a short circuit and erratic behaviour.

Pin Configuration	
3-Pin	5-Pin
	Pin 1 - Ground
	Pin 2 - Negative
	Pin 3 - Positive
-	Pin 4 - N/C
-	Pin 5 - N/C

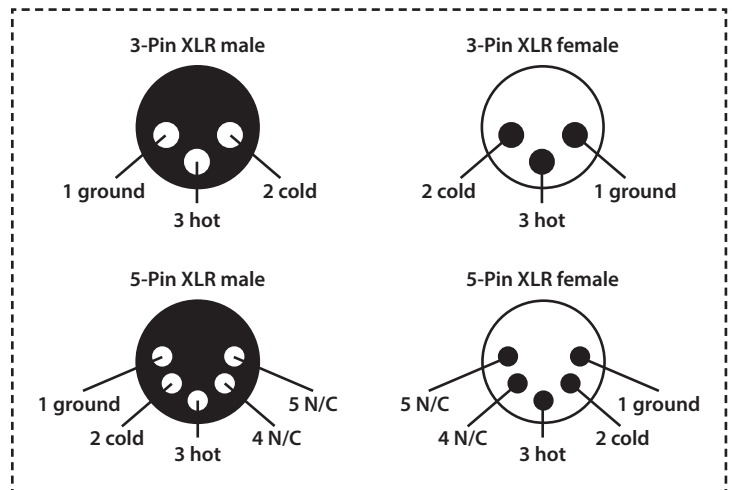
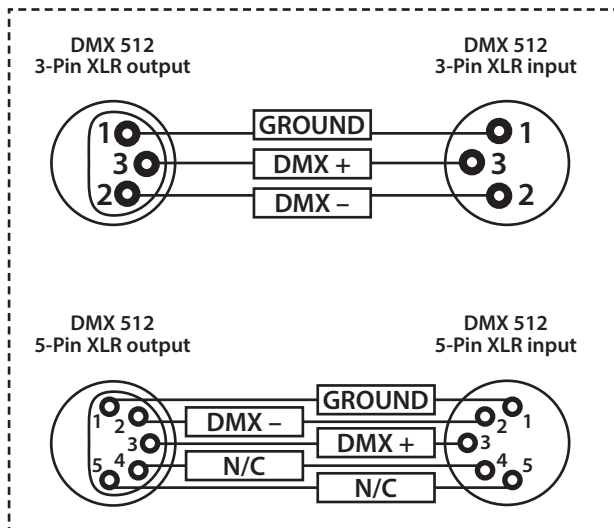

Line termination:

When longer runs of cable are used, you may need to use a terminator on the last unit to avoid erratic behaviour.

Using a cable terminator will decrease the possibilities of erratic behaviour.

(3-pin - Order ref: CABL90,
5-pin - Order ref: CABL89)

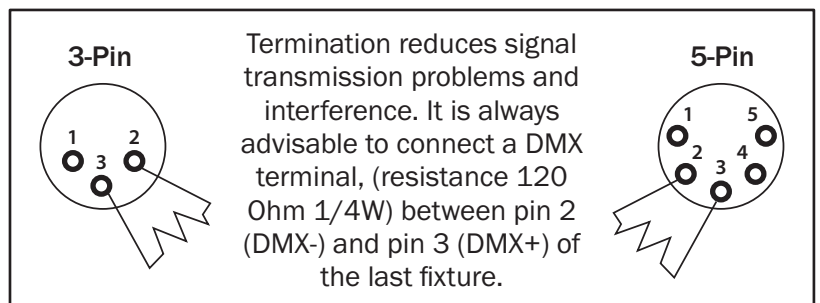

5-pin XLR DMX connectors:

Some manufactures use 5-pin XLR connectors for data transmission in place of 3-pin. 5-pin XLR fixtures may be implemented in a 3-pin XLR DMX line. When inserting standard 5-pin XLR connectors in to a 3-pin line a cable adaptor must be used. The diagram below details the correct cable conversion.

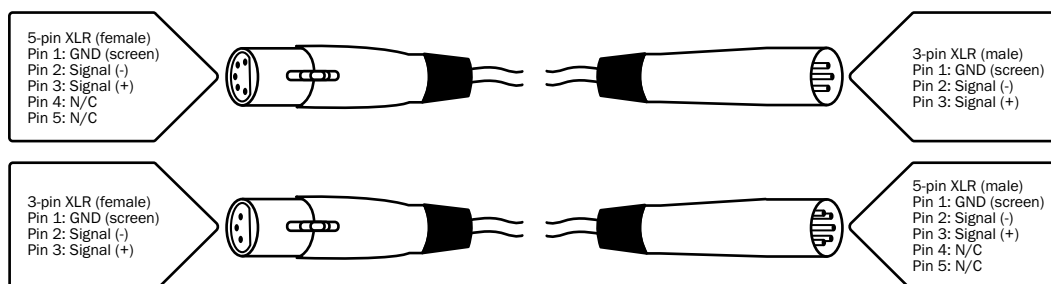

Power linking:

This fixture provides power linking via the power output on the rear allowing multiple units to be connected together. The maximum number of fixtures that can be connected is 4 fixtures @ 240V or 2 fixtures @ 120V (including the first fixture). After the maximum number of fixtures are connected a new power run will need to be started.

Please note: Caution should be used when power linking other fixtures to the Fusion 300FX Zoom Wash as the power consumption of other fixtures will vary. Fixtures fitted with lamps often require 2/3 times more current on startup, these may require their own power source.

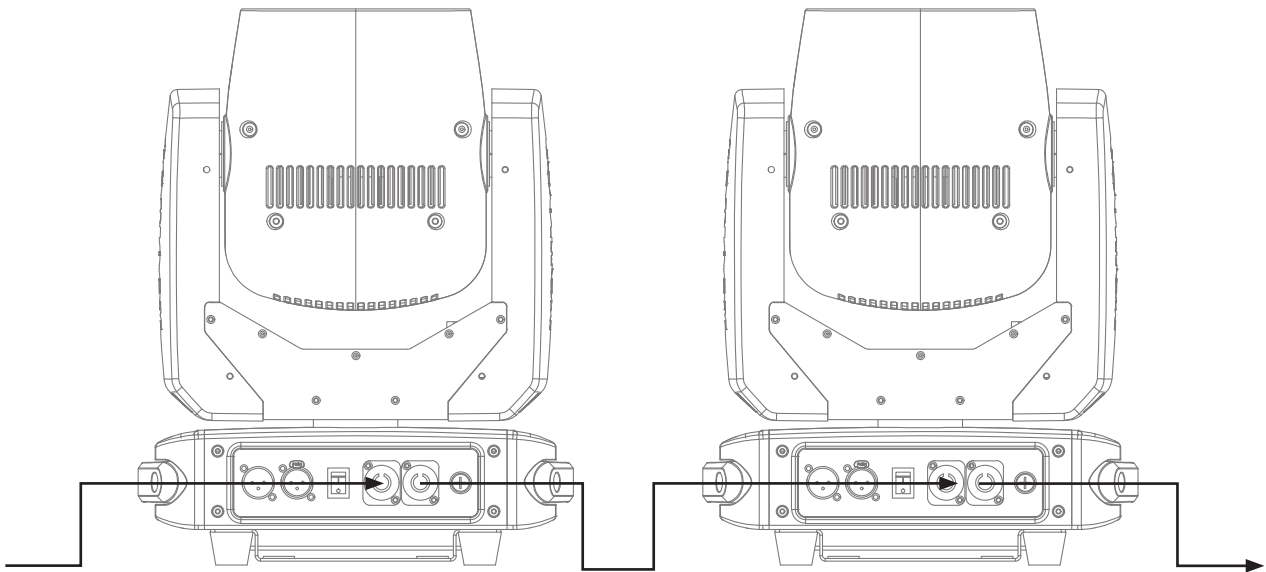



***Correct Disposal of this Product
(Waste Electrical & Electronic Equipment)***

**(Applicable in the European Union and other European countries
with separate collection systems)**

This marking shown on the product or its literature, indicates that it should not be disposed with other household wastes at the end of its working life. To prevent possible harm to the environment or human health from uncontrolled waste disposal, please separate this from other types of wastes and recycle it responsibly to promote the sustainable reuse of material resources.

Household users should contact either the retailer where they purchased this product, or their local government office, for details of where and how they can take this item for environmentally safe recycling.

Business users should contact their supplier and check the terms and conditions of the purchase contract. This product should not be mixed with other commercial wastes for disposal.

EQUINOX