

# **EQUINOX**

## **Quad Blox**

### **User Manual**



**Order code: EQLED458**

### WARNING

## FOR YOUR OWN SAFETY, PLEASE READ THIS USER MANUAL CAREFULLY BEFORE YOUR INITIAL START-UP!

- Before your initial start-up, please make sure that there is no damage caused during transportation.
- Should there be any damage, consult your dealer and do not use the equipment.
- To maintain the equipment in good working condition and to ensure safe operation, it is necessary for the user to follow the safety instructions and warning notes written in this manual.
- Please note that damages caused by user modifications to this equipment are not subject to warranty.



### IMPORTANT:

The manufacturer will not accept liability for any resulting damages caused by the non-observance of this manual or any unauthorised modification to the equipment.

- Never let the power cable come into contact with other cables. Handle the power cable and all mains voltage connections with particular caution!
- Never remove warning or informative labels from the unit.
- Do not open the equipment and do not modify the unit.
- Do not connect this equipment to a dimmer pack.
- Do not switch the equipment on and off in short intervals, as this will reduce the system's life.
- Only use the equipment indoors.
- Do not expose to flammable sources, liquids or gases.
- Always disconnect the power from the mains when equipment is not in use or before cleaning! Only handle the power-cable by the plug. Never pull out the plug by pulling the power-cable.
- Make sure that the available mains supply voltage is between 100~240V AC, 50/60Hz.
- Make sure that the power cable is never crimped or damaged. Check the equipment and the power cable periodically.
- If the equipment is dropped or damaged, disconnect the mains power supply immediately and have a qualified engineer inspect the equipment before operating again.
- If the equipment has been exposed to drastic temperature fluctuation (e.g. after transportation), do not connect power or switch it on immediately. The arising condensation might damage the equipment. Leave the equipment switched off until it has reached room temperature.
- If your product fails to function correctly, stop use immediately. Pack the unit securely (preferably in the original packing material), and return it to your Pro Light dealer for service.
- Only use fuses of same type and rating.
- Repairs, servicing and power connection must only be carried out by a qualified technician. THIS UNIT CONTAINS NO USER SERVICEABLE PARTS.
- This lighting fixture is for professional use only - it is not designed for or suitable for household use. The product must be installed by a qualified technician in accordance with local territory regulations. The safety of the installation is the responsibility of the installer. The fixture presents risks of severe injury or death due to fire hazards, electric shock and falls.
- Warning! Risk Group 2 LED product according to EN 62471. Do not view the light output with optical instruments or any device that may concentrate the beam.
- WARRANTY: One year from date of purchase.

### OPERATING DETERMINATIONS

If this equipment is operated in any other way, than those described in this manual, the product may suffer damage and the warranty becomes void. Incorrect operation may lead to danger e.g: short-circuit, burns and electric shocks etc.

Do not endanger your own safety and the safety of others!

Incorrect installation or use can cause serious damage to people and/or property.

**Please note:** These fixtures are intended for stage lighting and entertainment applications only, and are not intended for extended periods of use, including but not limited to house-light, industrial or architectural applications and should only be operated with short duty cycles.

### Quad Blox

Packed with sixteen 4W RGBWW LEDs, the Quad Blox delivers bold, vibrant colour with seamless blending and a removable frost filter for smooth washes. It features a variety of built-in shows accessible via the onboard menu or an included IR remote, facilitating straightforward plug-and-play operation. For advanced users, multiple DMX modes provide individual control over each segment, and the unit is compatible with W-DMX USB for wireless connectivity. The Quad Blox comes equipped with a dual bracket, allowing for flexible rigging or floor-standing setups.

- 16 x 4W quad-colour LEDs (RGBWW)
- Beam angle: 20°
- 30° frost filter included
- 1,605 Lux @ 2m (full on)
- Pixel zone mapping (4 segment)
- Refresh rate: 1200Hz
- DMX channels: 4/6/9/16/18 or 20 selectable
- W DMX USB compatibility for wireless primary/secondary or DMX control
- Auto, static colour, sound active, manual and primary/secondary modes
- 0 - 100% dimming
- Variable strobe

- Bracket allows for multiple rigging or floor standing applications
- 4 button menu with LED display
- Power Twist input/output
- 3-Pin XLR input/output
- Convection cooled
- Supplied with IR remote



Specifications	Quad Blox
Power consumption	70W
Power supply	100~240V, 50/60Hz
Fuse	T1.6A 250V
Dimensions	186.5 x 335 x 171.5mm
Weight	2.6kg
Order code	EQLED458

20° LUX no filter	2004	501	223	125	80	Red
30° LUX frost filter	868	217	96	54	35	
20° LUX no filter	2656	664	295	166	106	Green
30° LUX frost filter	1388	347	154	87	56	
20° LUX no filter	512	128	57	32	20	Blue
30° LUX frost filter	280	70	31	17	11	
20° LUX no filter	2480	620	276	155	99	White
30° LUX frost filter	1228	307	136	77	49	
20° LUX no filter	6420	1605	713	401	257	Full on
30° LUX frost filter	3112	778	346	194	124	

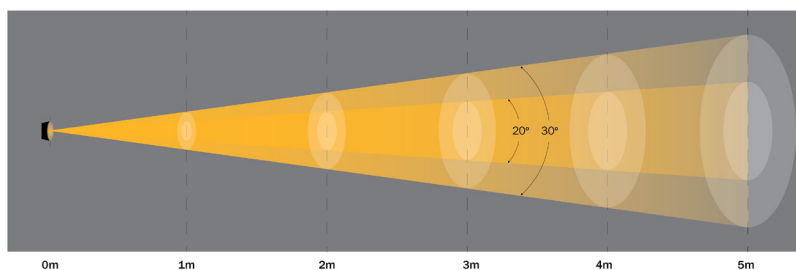

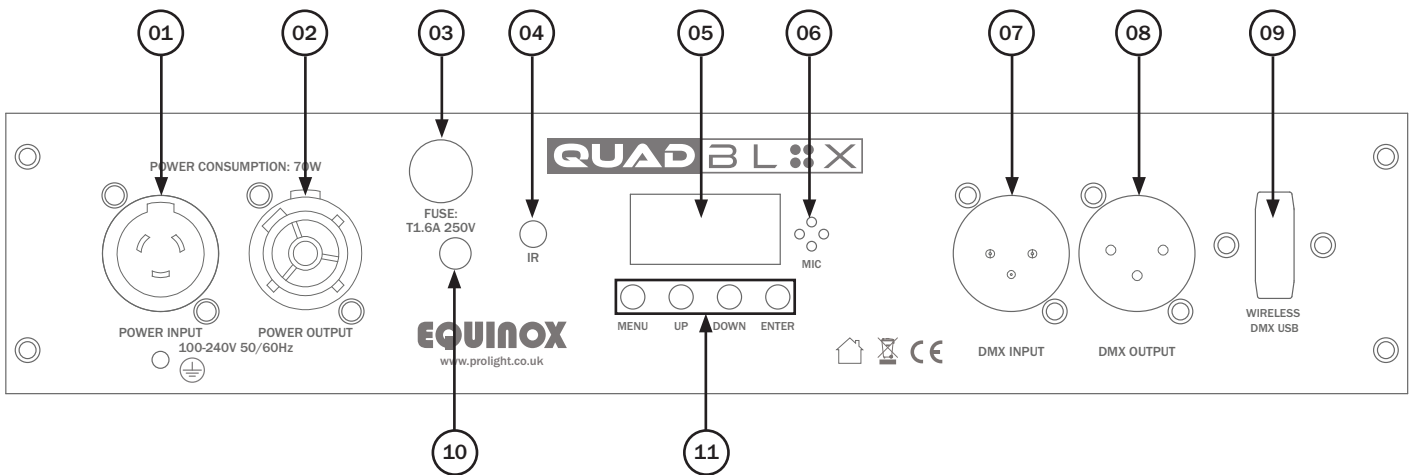
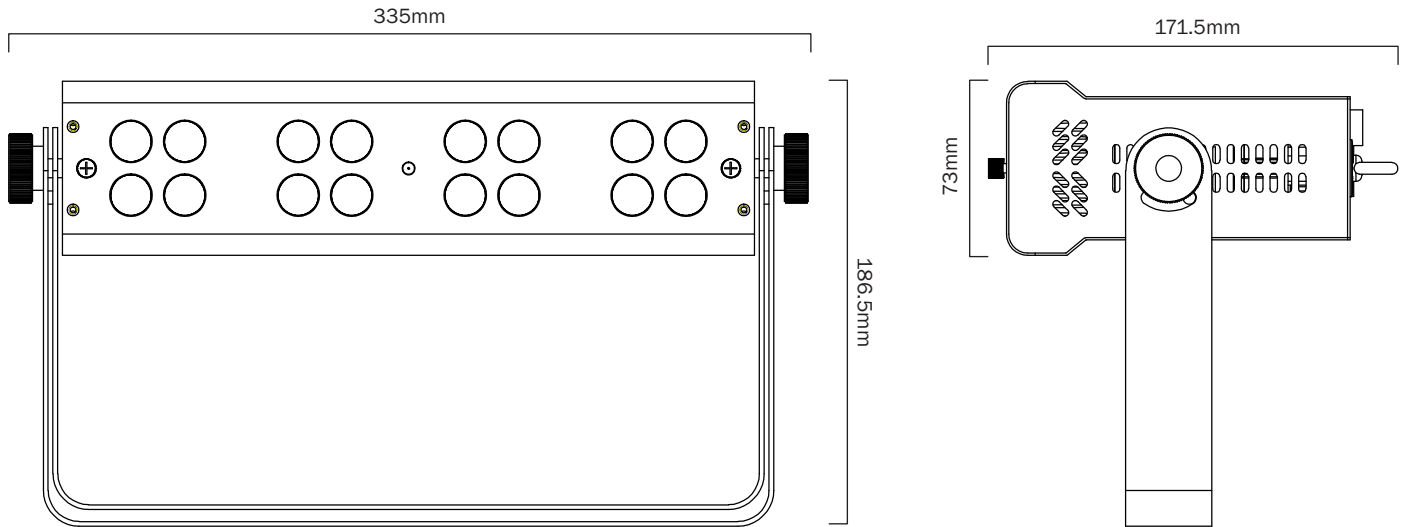

- |                         |                            |
|-------------------------|----------------------------|
| 01 - Power Twist input  | 07 - 3-Pin DMX input       |
| 02 - Power Twist output | 08 - 3-Pin DMX output      |
| 03 - Fuse: T1.6A 250V   | 09 - Wireless DMX USB port |
| 04 - IR sensor          | 10 - Safety eye            |
| 05 - LED display        | 11 - Function buttons      |
| 06 - Microphone         |                            |

In the box: **1 x fixture,**  
**1 x diffuser,**  
**1 x double bracket,**  
**1 x IR remote**  
**1 x power cable.**

Before installing the fixture, the supporting structure (ie. truss) must be able to hold a minimum of 10 times the fixtures weight without any deformation (eg. 15kg - 150kg point load). The fixture must be secured with a secondary safety attachment when being installed (ie. an appropriate safety cable). Never stand directly below the fixture when mounting, removing, and/or servicing.

Overhead installation requires experience and qualifications to calculate working load limits, the material being used at the installation area and periodic safety inspections of the fixture and installation material. If you do not have the relevant experience and/or qualifications please do not attempt the installation yourself. The installation should be checked annually by a qualified person.

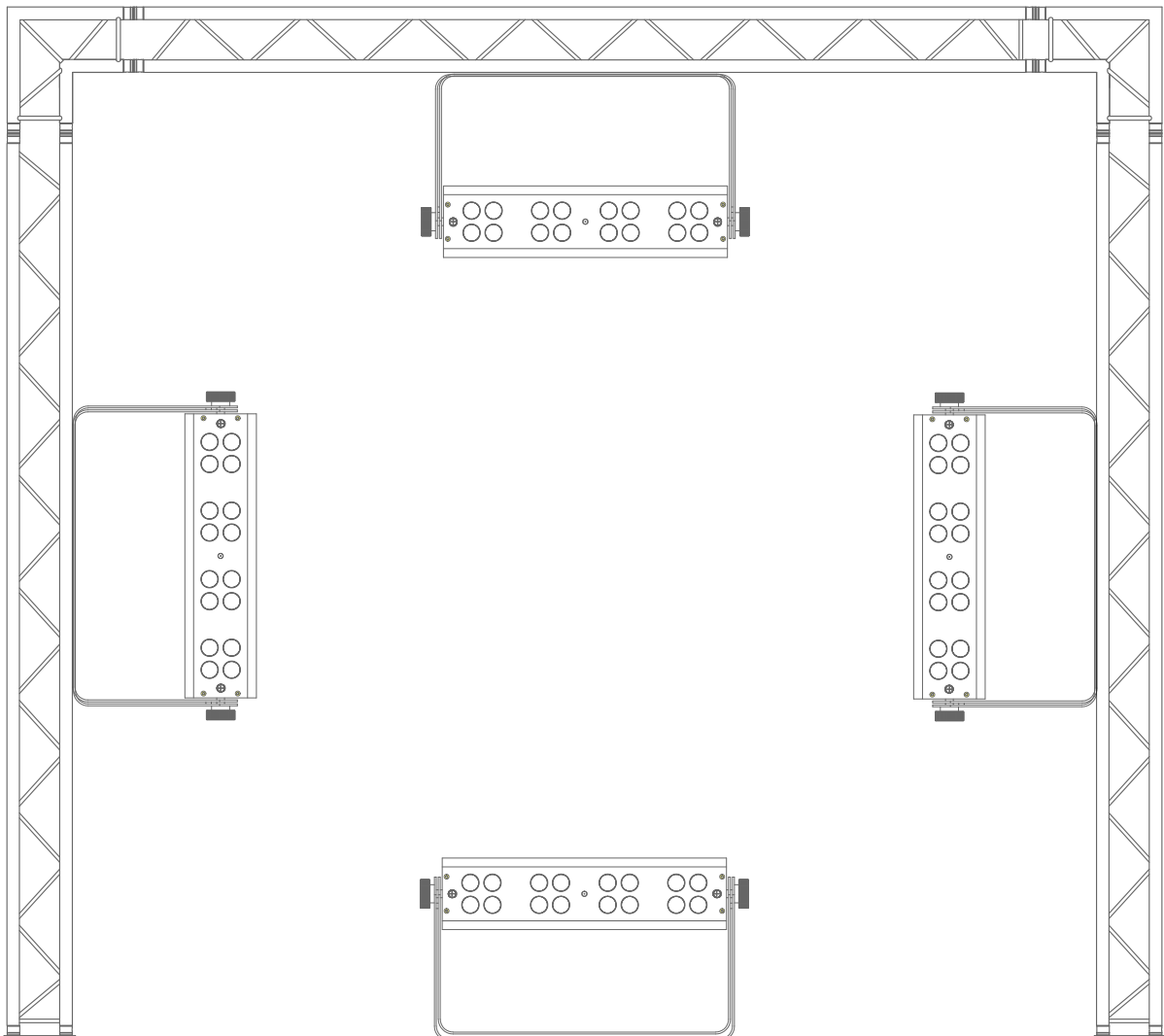

The Equinox Quad Blox can be operated in a number of mounting positions as shown in the diagram above, hanging upside-down from the ceiling or truss, mounting sideways on truss or stood upright on a flat level surface. Always use a safety wire as an extra safety precaution to prevent damage/injury in the event a clamp fails (see the next page for clamp installation).

Never use the carry handles for secondary attachments.

### Installation:

1. Fasten clamp to the hole on the bracket.
2. Mount the fixture onto your truss system via the clamp and tighten to ensure secure.
3. Pull the safety cable through the safety cable holes located on the metal base plate on the underside of the fixture and around the truss.

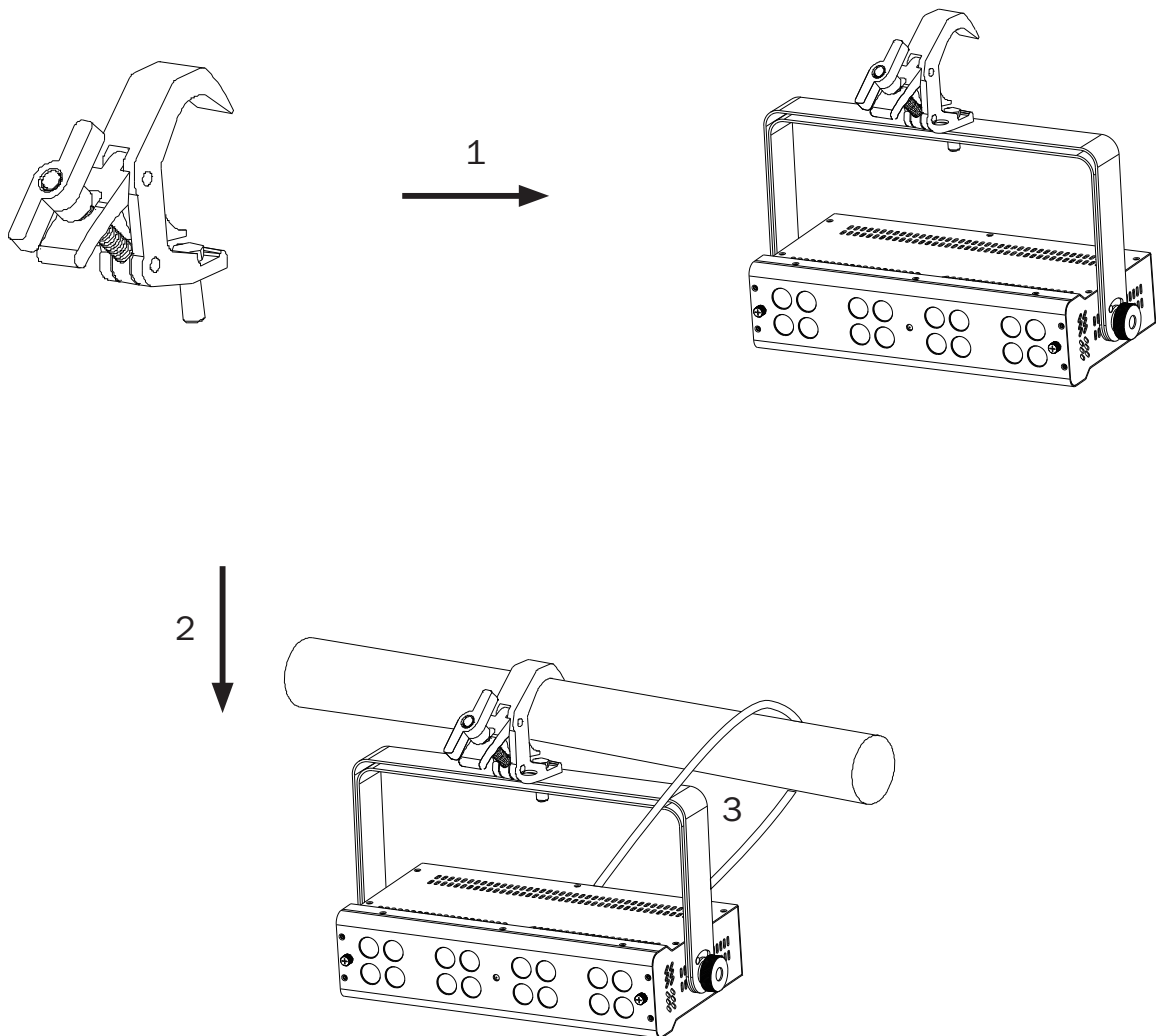

Main Menu - Defaults are in **grey**

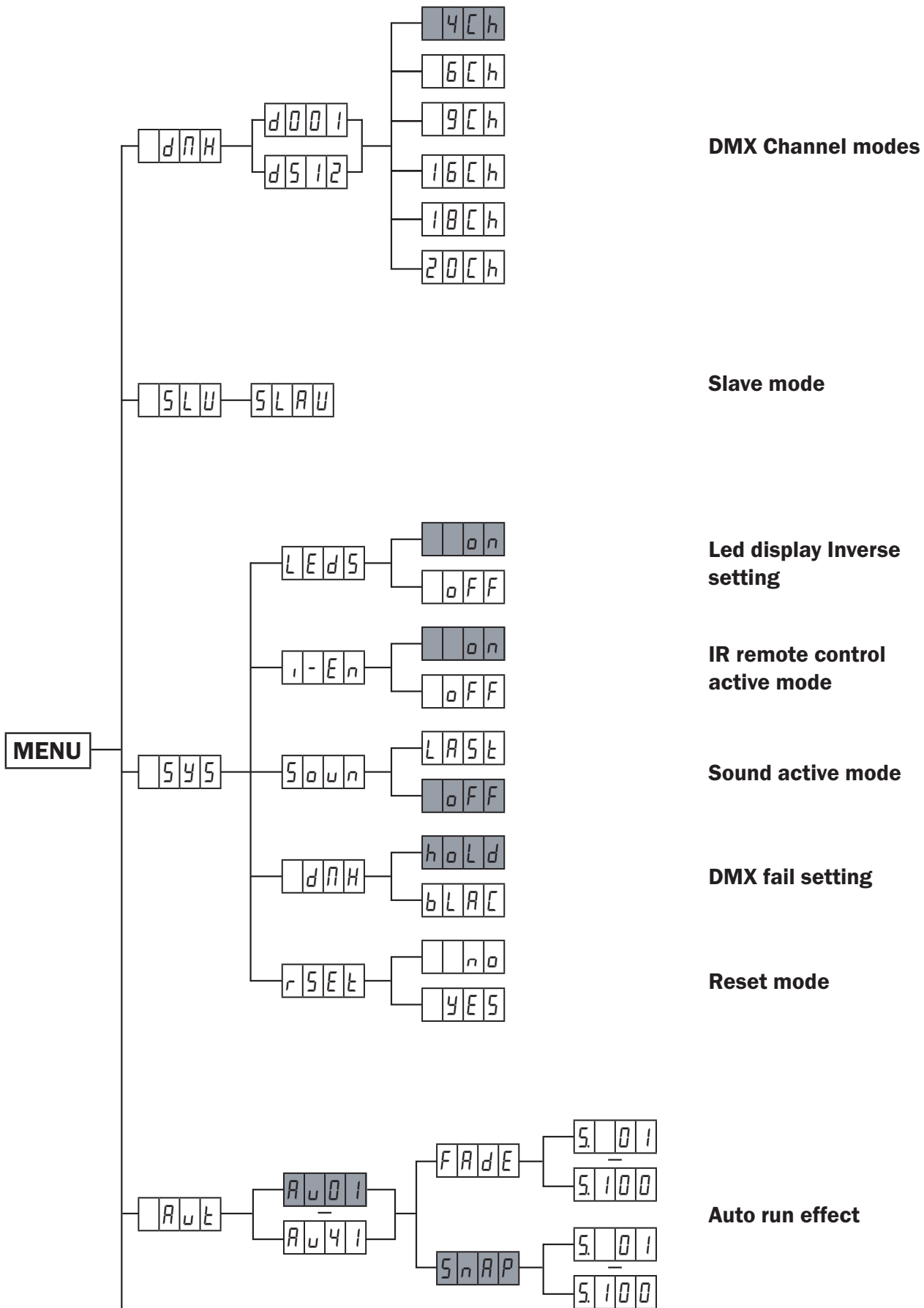

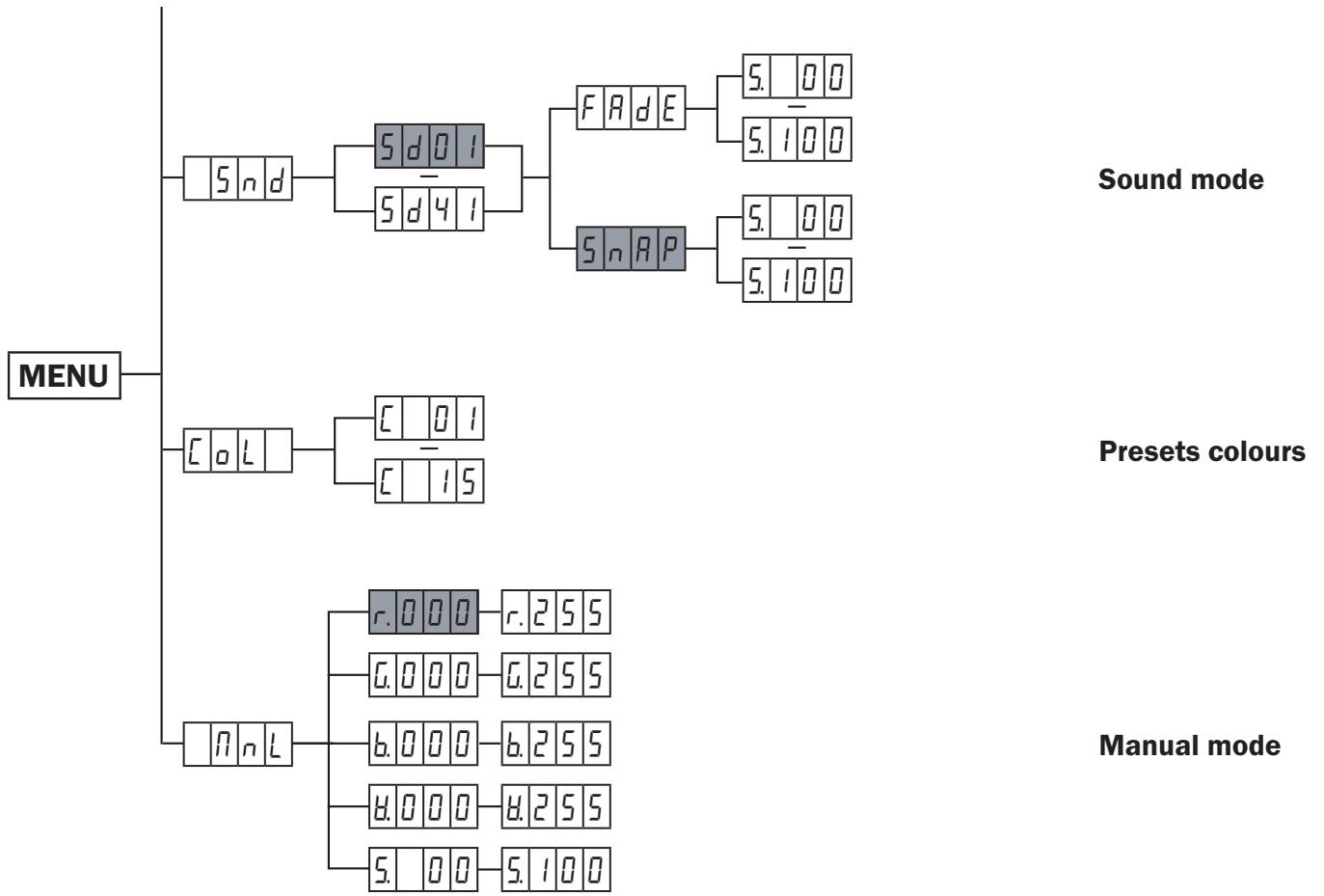

## DMX mode:

To access the DMX channel mode, press the “MENU” button on the rear of the unit and use the “UP” and “DOWN” buttons to show *dMH* on the LED display. Press the “ENTER” button and use the “UP” and “DOWN” buttons to select DMX address. Press the “ENTER” button and use the “UP” and “DOWN” buttons to choose one of the 4/6/9/16/18 or 20 DMX channel modes. Press the “ENTER” button to confirm the setting.

## 4 channel mode:

Channel	Value	Function
CH1	000-255	Red dimmer (0-100%)
CH2	000-255	Green dimmer (0-100%)
CH3	000-255	Blue dimmer (0-100%)
CH4	000-255	White dimmer (0-100%)

## 9 channel mode:

Channel	Value	Function
CH1	000-255	Red dimmer (0-100%)
CH2	000-255	Green dimmer (0-100%)
CH3	000-255	Blue dimmer (0-100%)
CH4	000-255	White dimmer (0-100%)
CH5	000-255	Master dimmer (0-100%)
CH6	000	No function
	001-255	Strobe (slow-fast)
CH7	000	No function
	001-006	Auto/Sound mode 1
	007-012	Auto/Sound mode 2
	013-018	Auto/Sound mode 3
	019-024	Auto/Sound mode 4
	025-030	Auto/Sound mode 5
	031-036	Auto/Sound mode 6
	037-042	Auto/Sound mode 7
	043-048	Auto/Sound mode 8
	049-054	Auto/Sound mode 9
	055-060	Auto/Sound mode 10
	061-066	Auto/Sound mode 11
	067-072	Auto/Sound mode 12
	073-078	Auto/Sound mode 13
	079-084	Auto/Sound mode 14
	085-090	Auto/Sound mode 15
	091-096	Auto/Sound mode 16
	097-102	Auto/Sound mode 17
	103-108	Auto/Sound mode 18
	109-114	Auto/Sound mode 19
115-120	Auto/Sound mode 20	
121-126	Auto/Sound mode 21	
127-132	Auto/Sound mode 22	
133-138	Auto/Sound mode 23	

## 6 channel mode:

Channel	Value	Function
CH1	000-255	Red dimmer (0-100%)
CH2	000-255	Green dimmer (0-100%)
CH3	000-255	Blue dimmer (0-100%)
CH4	000-255	White dimmer (0-100%)
CH5	000-255	Master dimmer (0-100%)
CH6	000	No function
	001-255	Strobe (slow-fast)

## 9 channel mode cont.

Channel	Value	Function
CH7	139-144	Auto/Sound mode 24
	145-150	Auto/Sound mode 25
	151-156	Auto/Sound mode 26
	157-162	Auto/Sound mode 27
	163-168	Auto/Sound mode 28
	169-174	Auto/Sound mode 29
	175-180	Auto/Sound mode 30
	181-186	Auto/Sound mode 31
	187-192	Auto/Sound mode 32
	193-198	Auto/Sound mode 33
	199-204	Auto/Sound mode 34
	205-210	Auto/Sound mode 35
	211-216	Auto/Sound mode 36
	217-222	Auto/Sound mode 37
	223-228	Auto/Sound mode 38
	229-234	Auto/Sound mode 39
235-240	Auto/Sound mode 40	
241-255	Auto/Sound mode 41	
CH8	000-200	Auto Speed (slow-fast)
	201-255	Sound Sensitivity (low-high)
CH9	000-127	Snap
	128-255	Fade

### 16 channel mode:

Channel	Value	Function	
CH1	000-255	Red dimmer (0-100%)	Segment 1
CH2	000-255	Green dimmer (0-100%)	
CH3	000-255	Blue dimmer (0-100%)	
CH4	000-255	White dimmer (0-100%)	
CH5	000-255	Red dimmer (0-100%)	Segment 2
CH6	000-255	Green dimmer (0-100%)	
CH7	000-255	Blue dimmer (0-100%)	
CH8	000-255	White dimmer (0-100%)	
CH9	000-255	Red dimmer (0-100%)	Segment 3
CH10	000-255	Green dimmer (0-100%)	
CH11	000-255	Blue dimmer (0-100%)	
CH12	000-255	White dimmer (0-100%)	
CH13	000-255	Red dimmer (0-100%)	Segment 4
CH14	000-255	Green dimmer (0-100%)	
CH15	000-255	Blue dimmer (0-100%)	
CH16	000-255	White dimmer (0-100%)	

### 18 channel mode:

Channel	Value	Function	
CH1	000-255	Red dimmer (0-100%)	Segment 1
CH2	000-255	Green dimmer (0-100%)	
CH3	000-255	Blue dimmer (0-100%)	
CH4	000-255	White dimmer (0-100%)	
CH5	000-255	Red dimmer (0-100%)	Segment 2
CH6	000-255	Green dimmer (0-100%)	
CH7	000-255	Blue dimmer (0-100%)	
CH8	000-255	White dimmer (0-100%)	
CH9	000-255	Red dimmer (0-100%)	Segment 3
CH10	000-255	Green dimmer (0-100%)	
CH11	000-255	Blue dimmer (0-100%)	
CH12	000-255	White dimmer (0-100%)	
CH13	000-255	Red dimmer (0-100%)	Segment 4
CH14	000-255	Green dimmer (0-100%)	
CH15	000-255	Blue dimmer (0-100%)	
CH16	000-255	White dimmer (0-100%)	
CH17	000-255	Master dimmer (0-100%)	
CH18	000	No function	
	001-255	Strobe (slow-fast)	

### 20 channel mode:

Channel	Value	Function	
CH1	000-255	Red dimmer (0-100%)	Segment 1
CH2	000-255	Green dimmer (0-100%)	
CH3	000-255	Blue dimmer (0-100%)	
CH4	000-255	White dimmer (0-100%)	
CH5	000	No function	
	001-255	Strobe (slow-fast)	
CH6	000-255	Red dimmer (0-100%)	Segment 2
CH7	000-255	Green dimmer (0-100%)	
CH8	000-255	Blue dimmer (0-100%)	
CH9	000-255	White dimmer (0-100%)	
CH10	000	No function	
	001-255	Strobe (slow-fast)	
CH11	000-255	Red dimmer (0-100%)	Segment 3
CH12	000-255	Green dimmer (0-100%)	
CH13	000-255	Blue dimmer (0-100%)	
CH14	000-255	White dimmer (0-100%)	
CH15	000	No function	
	001-255	Strobe (slow-fast)	
CH16	000-255	Red dimmer (0-100%)	Segment 4
CH17	000-255	Green dimmer (0-100%)	
CH18	000-255	Blue dimmer (0-100%)	
CH19	000-255	White dimmer (0-100%)	
CH20	000	No function	
	001-255	Strobe (slow-fast)	

### Primary/secondary mode:

To set the primary unit, press the “**MENU**” button and use the “**UP**” and “**DOWN**” buttons on the rear of the unit to select one of the built-in programs, sound programs or manual modes on the LED display. To set the other units in secondary mode, press the “**MENU**” button and use the “**UP**” and “**DOWN**” buttons on the rear of the unit to show *SLU* on the LED display. Press the “**ENTER**” button to confirm the setting. The unit/s will now run in sequence with the primary unit. Please ensure that all slave units are set to the same DMX channel mode as the primary unit.

### System setting:

To access system settings, press the “**MENU**” button and use the “**UP**” and “**DOWN**” buttons on the rear of the unit to show *545* on the LED display. Press the “**ENTER**” button for the following options to be displayed;

*LED5* – Display backlight

*00* – Display blacks out after the menu is not operated for a number of seconds

*0FF* – Display remains on

*I-En* – Infrared remote setting

*00* – IR remote control is enabled

*0FF* – IR remote control is disabled

*5000* – Set how the unit works when there is no sound

*LAST* – Last effect remains when no sound is detected

*0FF* – LEDs blackout when no sound is detected

*dFH* – DMX fail setting

*hold* – Holds the last value when DMX is lost

*blac* – LEDs blackout when DMX is lost

*r5E* – Resets the unit to default settings

*YES* – Confirms reset to default

*no* – Returns to previous menu

### Auto mode:

To access the auto modes, press the “**MENU**” button and use the “**UP**” and “**DOWN**” buttons on the rear of the unit to show *Aut* on the LED display. Press the “**ENTER**” button and use the “**UP**” and “**DOWN**” to select between *Aut 1* and *Aut 4*. Press the “**ENTER**” button and use the “**UP**” and “**DOWN**” to select between *Fade* (colour fade) or *SnAP* (colour change). Press the “**ENTER**” button and use the “**UP**” and “**DOWN**” to select the speed between *01* and *100* (slow-fast). Press the “**ENTER**” button to confirm the setting.

### Sound mode:

To access the auto modes, press the “MENU” button and use the “UP” and “DOWN” buttons on the rear of the unit to show *Sound* on the LED display. Press the “ENTER” button and use the “UP” and “DOWN” to select between *ADD1* and *ADD4*. Press the “ENTER” button and use the “UP” and “DOWN” to select between *FADE* (colour fade) or *SNAP* (colour change). Press the “ENTER” button and use the “UP” and “DOWN” to select the sensitivity between *01* and *100* (low-high). Press the “ENTER” button to confirm the setting.

### Static colour mode:

To access the static colour mode, press the “MENU” button and use the “UP” and “DOWN” buttons on the rear of the unit to show *COL* on the LED display. Press the “ENTER” button and use the “UP” and “DOWN” to select between *CO01* and *CO15*. Press the “ENTER” button to confirm the setting.

\* Colour setup:

<i>CO01</i> - Red	<i>CO06</i> - Magenta	<i>CO11</i> - Lavender
<i>CO02</i> - Green	<i>CO07</i> - Lime	<i>CO12</i> - Yellow
<i>CO03</i> - Blue	<i>CO08</i> - Baby Blue	<i>CO13</i> - Purple
<i>CO04</i> - Warm white	<i>CO09</i> - Salmon	<i>CO14</i> - Sky Blue
<i>CO05</i> - Cyan	<i>CO10</i> - Lawn Green	<i>CO15</i> - White (full on)

### Manual mode:

To access the manual mode, press the “MENU” button and use the “UP” and “DOWN” buttons on the rear of the unit to show *MAN!* on the LED display. Press the “ENTER” button and use the “UP” and “DOWN” to select the red dimmer between *r.000* and *r.255*. Press the “ENTER” button and use the “UP” and “DOWN” to repeat for *G* (green), *b* (Blue), *H* (warm white) and *S* (strobe). Press the “ENTER” button to confirm the setting.

(LED brightness 000 = off, 255 = full brightness, strobe speed 00 = off, 100 = fast)

### IR remote functions:

- 01 - Enables **AUTO MODE** - use ◀▶ and ▶▶ to select program. Press ⏻ and use ◀▶ and ▶▶ to adjust speed.
- 02 - Enables **SOUND MODE** use ◀▶ and ▶▶ to select program.
- 03 - **BLACKOUT**
- 04 - Use to select **AUTO SOUND** program, program **SPEED**, colour brightness or **STATIC COLOUR**
- 05 - Pauses **AUTO/SOUND** programs
- 06 - **RED** - use ◀▶ and ▶▶ to adjust brightness
- 07 - **GREEN** - use ◀▶ and ▶▶ to adjust brightness
- 08 - **BLUE** - use ◀▶ and ▶▶ to adjust brightness
- 09 - **RED**
- 10 - **ORANGE**
- 11 - **YELLOW**
- 12 - **GREEN**
- 13 - **BLUE**
- 14 - **BLUE**
- 15 - **PINK**
- 16 - **WARM WHITE**
- 17 - **FULL ON**
- 18 - **STATIC COLOURS** - use ◀▶ and ▶▶ to select colour
- 19 - **WARM WHITE** - use ◀▶ and ▶▶ to adjust brightness
- 20 - Changes between **AUTO MODE** and **AUTO MODE SPEED**

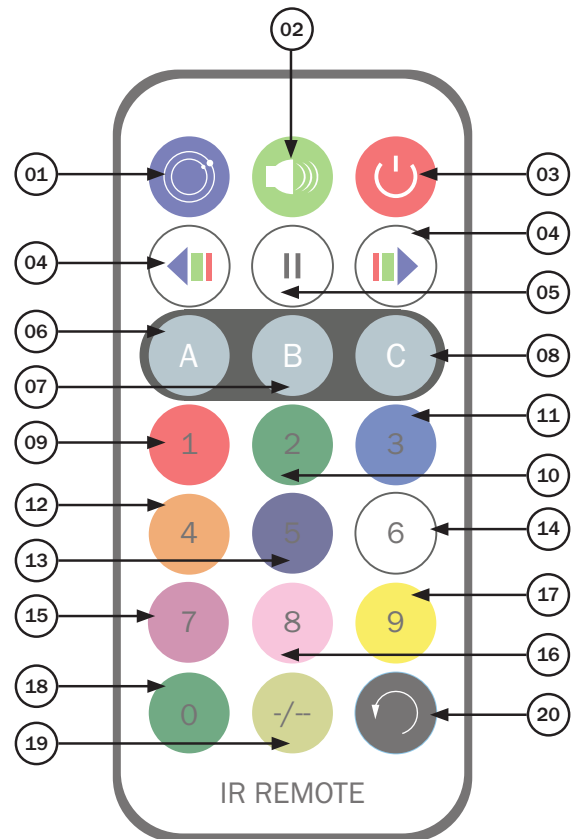

### Remote Control Identification:

- 01 - When installing the battery (**Type CR2025**) please ensure the battery is orientated to maintain correct polarity following the + and - symbols.
- 02 - The remote control should be aimed directly at the IR receiver window from a distance of up to 8m.
- 03 - Should the working distance or the remote become reduced, or the remote becomes unresponsive, please change battery taking care to install a high-quality replacement.
- 04 - Please remove the battery and store safely when unused for long periods of time.
- 05 - The remote control should be handled carefully and protected from damage.

### Setting the DMX address:

The DMX mode enables the use of a universal DMX controller. Each fixture requires a “start address” from 1- 512. A fixture requiring one or more channels for control begins to read the data on the channel indicated by the start address. For example, a fixture that occupies or uses 7 channels of DMX and was addressed to start on DMX channel 100, would read data from channels: 100, 101, 102, 103, 104, 105 and 106. Choose a start address so that the channels used do not overlap. E.g. the next unit in the chain starts at 107.

### DMX 512:

DMX (Digital Multiplex) is a universal protocol used as a form of communication between intelligent fixtures and controllers. A DMX controller sends DMX data instructions from the controller to the fixture. DMX data is sent as serial data that travels from fixture to fixture via the DATA “IN” and DATA “OUT” XLR terminals located on all DMX fixtures (most controllers only have a data “out” terminal).

### DMX linking:

DMX is a language allowing all makes and models of different manufacturers to be linked together and operate from a single controller, as long as all fixtures and the controller are DMX compliant. To ensure proper DMX data transmission, when using several DMX fixtures try to use the shortest cable path possible. The order in which fixtures are connected in a DMX line does not influence the DMX addressing. For example; a fixture assigned to a DMX address of 1 may be placed anywhere in a DMX line, at the beginning, at the end, or anywhere in the middle. When a fixture is assigned a DMX address of 1, the DMX controller knows to send DATA assigned to address 1 to that unit, no matter where it is located in the DMX chain.

### DATA cable (DMX cable) requirements (for DMX operation):

This fixture can be controlled via DMX-512 protocol. The DMX address is set on the back of the unit. Your unit requires a standard 3-pin XLR connector for data input/output, see images below. Using audio XLR cables for DMX lighting is discouraged because it causes signal degradation, leading to flickering, erratic, or non-responsive lights. Audio cables have different impedance (<75  $\Omega$ ) and higher capacitance, which cannot accurately transmit high-speed digital DMX data (110-120  $\Omega$ ). While it may work for short, simple setups, it is unreliable for professional, long-distance, or complex lighting rigs. Ensure you use DMX XLR cables.



Further DMX cables can be purchased from all good sound and lighting suppliers or Prolight Concepts dealers.  
Please quote: 3-Pin: **CABL10 – 2m** **CABL11 – 5m** **CABL12 – 10m**

**Also remember that DMX cable must be daisy chained and cannot be split.**

**Notice:**

Be sure to follow the diagrams below when making your own cables. Do not connect the cables shield conductor to the ground lug or allow the shield conductor to come in contact with the XLRs outer casing. Grounding the shield could cause a short circuit and erratic behaviour.

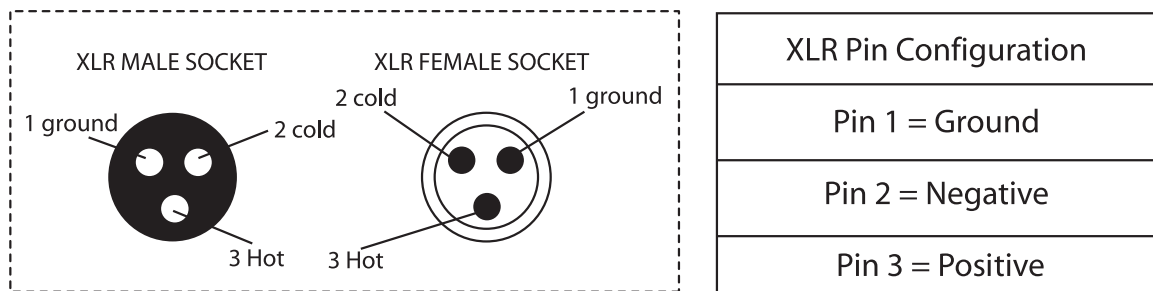
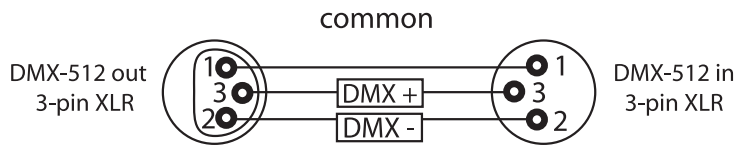

**Special note:**

**Line termination:**

When longer runs of cable are used, you may need to use a terminator on the last unit to avoid erratic behaviour.

**Using a cable terminator will decrease the possibilities of erratic behaviour.**

**(3-pin - Order ref: CABL90, 5-pin - Order ref: CABL89)**

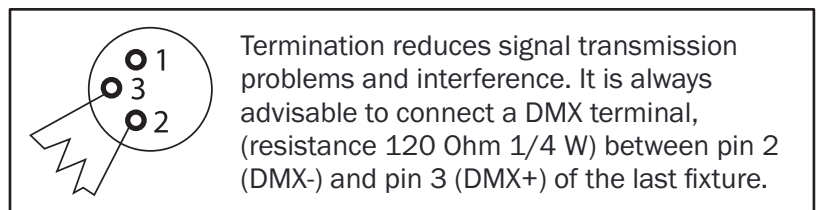

**5-pin XLR DMX connectors:**

Some manufactures use 5-pin XLR connectors for data transmission in place of 3-pin. 5-pin XLR fixtures may be implemented in a 3-pin XLR DMX line. When inserting standard 5-pin XLR connectors in to a 3-pin line a cable adaptor must be used. The diagram below details the correct cable conversion.

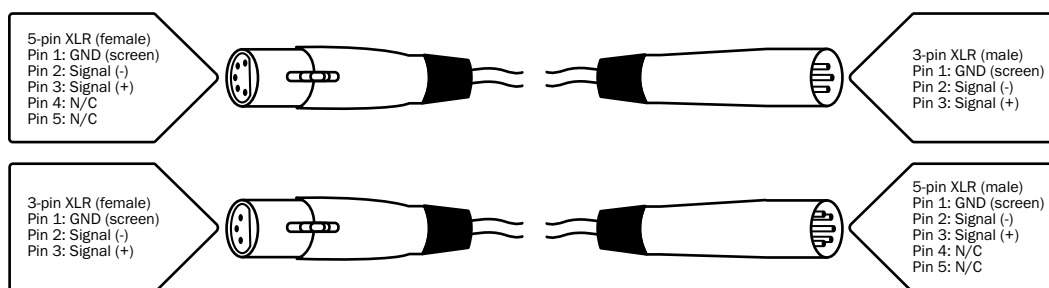

### Power linking:

This fixture provides power linking via the power output on the rear allowing multiple units to be connected together. The maximum number of fixtures that can be connected is 16 fixtures @ 240V or 8 fixtures @ 120V (including the first fixture). After the maximum number of fixtures are connected a new power run will need to be started.

Please note: Caution should be used when power linking other fixtures to the Quad Blox as the power consumption of other fixtures will vary. Fixtures fitted with lamps often require 2/3 times more current on startup, these may require their own power source.

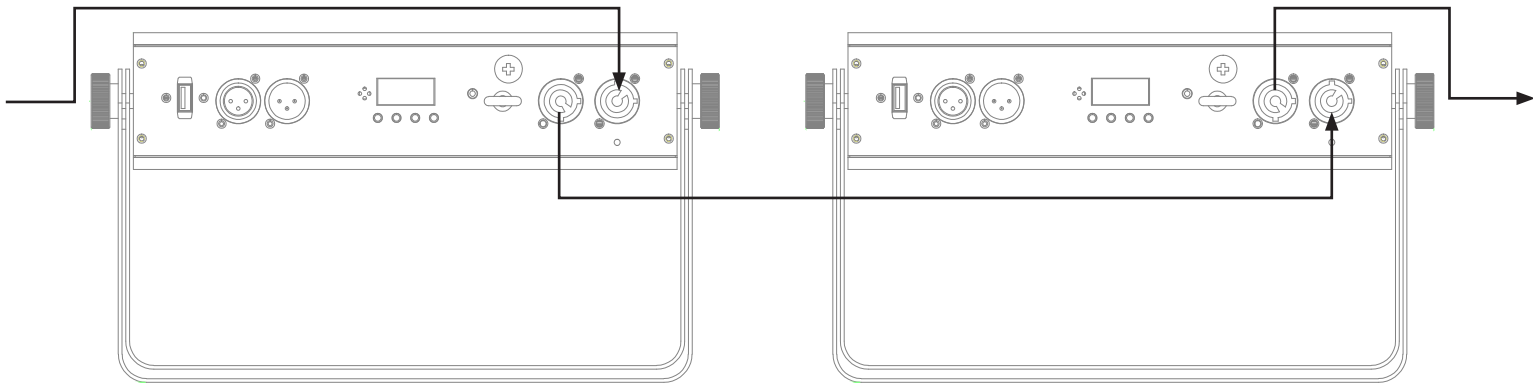



### ***Correct Disposal of this Product (Waste Electrical & Electronic Equipment)***

**(Applicable in the European Union and other European countries  
with separate collection systems)**

This marking shown on the product or its literature, indicates that it should not be disposed of with other household wastes at the end of its working life. To prevent possible harm to the environment or human health from uncontrolled waste disposal, please separate this from other types of wastes and recycle it responsibly to promote the sustainable reuse of material resources.

Household users should contact either the retailer where they purchased this product, or their local government office, for details of where and how they can take this item for environmentally safe recycling.

Business users should contact their supplier and check the terms and conditions of the purchase contract. This product should not be mixed with other commercial wastes for disposal.

