

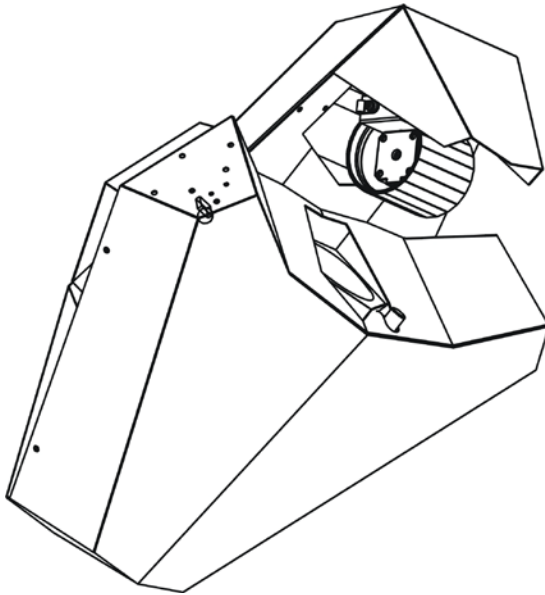

GA-275B



User Manual

Professional Entertainment Technolog

TABLE OF CONTENTS

1. Safety Instruction
2. Technical Specification
3. Lamp
4. Control Panel
5. How to Control the Unit
 - 5.1 Master/Slave operation
 - 5.2 Easy controller CA-8
 - 5.3 Universal DMX controller
 - 5.4 DMX 512 Configuration
 - 5.5 DMX 512 Connection
6. Troubleshooting
7. Fixture Cleaning

1.Safety Instruction



WARNING

Please read the instruction carefully which including important information about the installation, operation and maintenance.

- Please keep this User Guide for future consultation. If you sell the unit to another user, be sure that they also receive this instruction booklet.
- Unpack and check carefully there is no transportation damage before using the unit.
- Before operating, ensure that the voltage and frequency of power supply match the power requirements of the unit.
- It's important to ground the yellow/green conductor to earth in order to avoid electric shock.
- The unit is for indoor use only. Use only in a dry location.
- The unit must be installed in a location with adequate ventilation, at least 50cm from adjacent surfaces. Be sure that no ventilation slots are blocked.
- Disconnect main power before replacement or servicing.
- Make sure there is no flammable materials close to the unit while operating as it is fire hazard.
- Use safety cable when fixes this unit. Don't handle the unit by taking its head only, but always by taking its base.
- Maximum ambient temperature is t_a : 40°C. Don't operate it where the temperature is higher than this.
- Unit surface temperature may reach up to 85°C. Don't touch the housing bare-hand during its operation. Turn off the power and allow about 15 minutes for the unit to cool down before replacing or serving.
- In the event of serious operating problem, stop using the unit immediately. Never try to repair the unit by yourself. Repairs carried out by unskilled people can lead to damage or malfunction. Please contact the nearest authorized technical assistance center. Always use the same type spare parts.
- Do not touch any wire during operation as high voltage might be causing electric shock.
- Always use the same type spare parts.

Warning

- To prevent or reduce the risk of electrical shock or fire, do not expose the unit to rain or moisture.
- Do not open the unit within 15 minutes after switching off.
- The housing, the lenses, or the ultraviolet filter must be replaced if they are visibly damaged..
- Do not turn on the unit without lamp.
- Hot lamp explosion hazard. Do not open the unit within five minutes after switching off.
- Do not look directly at the light beam while the fixture is on.

Caution

There are no user serviceable parts inside the unit. Do not open the housing or attempt any repairs yourself. In the unlikely event your unit may require service, please contact your nearest dealer.

Installation

The unit should be mounted via its screw holes on the bracket. Always ensure that the unit is firmly fixed to avoid vibration and slipping while operating. And make sure that the structure to which you are attaching the unit is secure and is able to support a weight of 10 times of the unit's weight. Also always use a safety cable that can hold 12 times of the weight of the unit when installing the fixture.

The equipment must be fixed by professionals. And it must be fixed at a place where is out of the touch of people and has no one pass by or under it.

2. Technical Specification

- The unit is DMX 512 fixture. It can also be control by CA-8 in master/slave mode.
- It can be also linked together in master/slave connection, as many as required and run by built-in program automatically or by sound activation through an internal microphone to create an intelligent effect.
- Use 3-pin XLR cable connect units together.

- Voltage: AC 230V ~50/60Hz
- Lamp: MSD 250
- Power Consumption: 320W
- Fuse: T 5A
- Dimension: 519 x 557 x 208 mm
- Weight: 14kgs

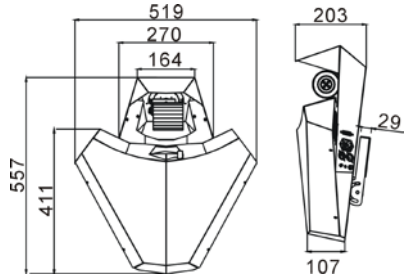

3. Lamp

DANGER!

In case of replacement of the lamp or maintenance, do not open the fixture within 15 minutes until the unit cools down after switching off.

Because of its high internal pressure, there might be a risk that the Discharge lamp would explode during operation. The lamp emits intense UV radiation which is harmful to the eyes and skin. The high luminance of the arc can cause severe damage to the retina if looks directly at the lamp.

MSD 250

1. Always switch off the main supply and never handle the lamp or luminaries when is hot.
2. Do not touch the bulb with bare hands. If this happens, clean the lamp with denatured alcohol and wipe it with a lint free cloth before installation.
3. The lamp generates UV radiation. Never operate the lamp without appropriate shielding.
4. When burning, the lamp operates at high pressure and there is a slight risk of arc tube rupture. The risk increases with age, temperature and improper handling of the lamp. Do not use the lamp any longer than its specified life.

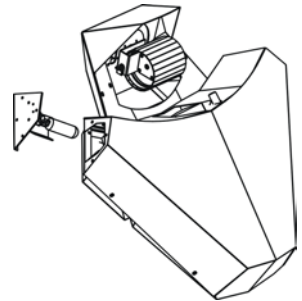

Make sure the lamp is located in the center of the reflector for the best spot.

4. Control Panel

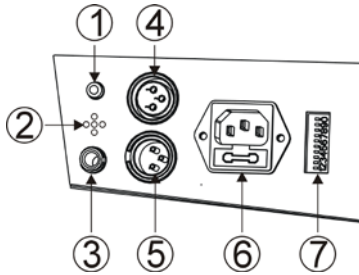

1. **Sensitivity:** Adjust sensitivity of the sound control.
2. **Microphone:** Receive music for sound active.
3. **Only for remote control:** By connect to the 1/4" microphone jack to control the unit for Stand by, Function and Mode function.
4. **DMX input:** For DMX512 link, use 3-pin XLR plug cable to input DMX signal
5. **DMX output:** For DMX512 link, use 3-pin XLR plug cable to link the next unit.
6. **Mains Power:** Connect to supply mains power.
7. **Dip-Switchs:** Master or slave mode setting.

5. How to Control The Unit

Three ways to operation:

- A. Master/Slave operation
- B. Easy controller CA-8
- C. Universal DMX controller

No need to turn the unit off when you change the DMX address, as new DMX address setting will be effected at once. Every time you turn the unit on, it will move all the motors to their 'home' position and you may hear some noises for about 20 seconds. After that the unit will be ready to receive DMX signal or run the built in programs.

5.1 Master/Slave operation

The unit can be linked together in daisy chain as many as you need in master/slave mode to perform the great built-in pre-programmed lighting shows triggered by music.

In Master/Slave mode refer to the DMX settings below:

Master unit: Dip-switch must be set to 001(dip switch 1 ON, others OFF)

Slave unit: Dip-switch can be any value except 001. (example: set dip switch 3 ON)

5.2 Easy controller CA-8

The easy remote control is used only in master/slave mode. By connecting to the 1/4" microphone jack of the first unit, you will find that the remote controller on the first unit will control all the other units for Stand by, Function and Mode selection

Blackout	Black out	
Function	Sound strobe	1、 Hold to select GOBO 2、 Press to select color
Mode	Sound (LED OFF)	LED ON

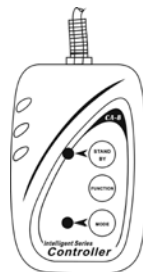

5.3 Universal DMX Controller

When using a universal DMX controller to control the chain of units, you have to set DMX address by Dip switches from 1 to 9 to make sure all the units will receive its DMX signal. The dip switch 10 is used to choose channel mode (ON is 8 channels mode, OFF is 11 channels mode). Please refer to the following diagram to address your DMX 512 system in the binary code.

Dip-switch	# 1	# 2	# 3	# 4	# 5	# 6	# 7	# 8	# 9	#10
Value	1	2	4	8	16	32	64	128	256	8CH/11CH

Example:

Dip-switch 10 ON: 8 channels mode

channel 1: dip / on: #1 (=1)

channel 9: dip / on: #1, #4 (1+8=9)

channel 17: dip / on: #1, #5 (1+16=17)

channel 25: dip / on: #1, #4, #5 (2+8=10)

Channel	Dip switches setting
1	<div style="display: flex; align-items: center;"> <div style="margin-right: 5px;">↓</div> <div style="display: flex; gap: 5px;"> <div style="border: 1px solid black; width: 15px; height: 15px; background-color: white;"></div> <div style="border: 1px solid black; width: 15px; height: 15px; background-color: white;"></div> <div style="border: 1px solid black; width: 15px; height: 15px; background-color: white;"></div> <div style="border: 1px solid black; width: 15px; height: 15px; background-color: white;"></div> <div style="border: 1px solid black; width: 15px; height: 15px; background-color: white;"></div> <div style="border: 1px solid black; width: 15px; height: 15px; background-color: white;"></div> <div style="border: 1px solid black; width: 15px; height: 15px; background-color: white;"></div> <div style="border: 1px solid black; width: 15px; height: 15px; background-color: white;"></div> <div style="border: 1px solid black; width: 15px; height: 15px; background-color: white;"></div> <div style="border: 1px solid black; width: 15px; height: 15px; background-color: white;"></div> </div> </div>
9	<div style="display: flex; align-items: center;"> <div style="margin-right: 5px;">↓</div> <div style="display: flex; gap: 5px;"> <div style="border: 1px solid black; width: 15px; height: 15px; background-color: white;"></div> <div style="border: 1px solid black; width: 15px; height: 15px; background-color: white;"></div> <div style="border: 1px solid black; width: 15px; height: 15px; background-color: white;"></div> <div style="border: 1px solid black; width: 15px; height: 15px; background-color: white;"></div> <div style="border: 1px solid black; width: 15px; height: 15px; background-color: white;"></div> <div style="border: 1px solid black; width: 15px; height: 15px; background-color: white;"></div> <div style="border: 1px solid black; width: 15px; height: 15px; background-color: white;"></div> <div style="border: 1px solid black; width: 15px; height: 15px; background-color: white;"></div> <div style="border: 1px solid black; width: 15px; height: 15px; background-color: white;"></div> <div style="border: 1px solid black; width: 15px; height: 15px; background-color: white;"></div> </div> </div>
17	<div style="display: flex; align-items: center;"> <div style="margin-right: 5px;">↓</div> <div style="display: flex; gap: 5px;"> <div style="border: 1px solid black; width: 15px; height: 15px; background-color: white;"></div> <div style="border: 1px solid black; width: 15px; height: 15px; background-color: white;"></div> <div style="border: 1px solid black; width: 15px; height: 15px; background-color: white;"></div> <div style="border: 1px solid black; width: 15px; height: 15px; background-color: white;"></div> <div style="border: 1px solid black; width: 15px; height: 15px; background-color: white;"></div> <div style="border: 1px solid black; width: 15px; height: 15px; background-color: white;"></div> <div style="border: 1px solid black; width: 15px; height: 15px; background-color: white;"></div> <div style="border: 1px solid black; width: 15px; height: 15px; background-color: white;"></div> <div style="border: 1px solid black; width: 15px; height: 15px; background-color: white;"></div> <div style="border: 1px solid black; width: 15px; height: 15px; background-color: white;"></div> </div> </div>
25	<div style="display: flex; align-items: center;"> <div style="margin-right: 5px;">↓</div> <div style="display: flex; gap: 5px;"> <div style="border: 1px solid black; width: 15px; height: 15px; background-color: white;"></div> <div style="border: 1px solid black; width: 15px; height: 15px; background-color: white;"></div> <div style="border: 1px solid black; width: 15px; height: 15px; background-color: white;"></div> <div style="border: 1px solid black; width: 15px; height: 15px; background-color: white;"></div> <div style="border: 1px solid black; width: 15px; height: 15px; background-color: white;"></div> <div style="border: 1px solid black; width: 15px; height: 15px; background-color: white;"></div> <div style="border: 1px solid black; width: 15px; height: 15px; background-color: white;"></div> <div style="border: 1px solid black; width: 15px; height: 15px; background-color: white;"></div> <div style="border: 1px solid black; width: 15px; height: 15px; background-color: white;"></div> <div style="border: 1px solid black; width: 15px; height: 15px; background-color: white;"></div> </div> </div>

Dip-switch OFF: 11 channels mode

channel 1: dip / on: #1 (=1)

channel 12: dip / on: #1, #2, #4 (1+2+8=11)

channel 23: dip / on: #1, #2, #3, #5 (1+2+4+16=23)

channel 34: dip / on: #2, #6 (2+32=34)

Channel	Dip switches setting
1	
12	
23	
34	















65. 4 DMX512 Configuration

8channels mode:

DMX 512 Configuration							
CH1	CH2	CH3	CH4	CH5	CH6	CH7	CH8
Dimmer/ Strobe	Moon Flower Moment	Color	Color Shaking	Gobo	Gobo Shaking	Pan Movement	Tilt Movement
249-255 Open	255 Fast	255 Fast					255 Fast
240-248 Reset			255 Fast	255 Fast		255 Fast	Tilt Shaking With Big Area
210-239 Open	196 Slow	192 Slow			255 Fast		196 Slow
200-209 Random Strobe	192-195 Stop	191 Fast	Shaking With Big Area			Shaking With Big Area	192-195 Stop
190-199 Open	191 Fast	128 Slow		128 Slow			191 Fast
128-189 100%		120-127 Color 16	136 Slow	118-127 Gobo 14	136 Slow		Tilt Shaking With Small Area
	132 Slow	113-119 Color 15		109-117 Gobo 13			132 Slow
	128-131 Stop	098-104 Color 13		100-108 Gobo 12			128-131 Stop
	127 Fast	083-089 Color 11	135 Fast	82-90 Gobo 10	135 Fast	191 Fast	127 Fast
		075-082 Color 10	Shaking With Small Area	73-81 Gobo 9	Shaking With Small Area	Shaking With Small Area	
	68 Slow	068-074 Color 9	16 Slow	64-72 Gobo 8		128 Slow	68 Slow
	64-67 Stop	063-069 Color 8		55-63 Gobo 7	16 Slow		64-67 Stop
	63 Slow	053-059 Color 7		46-54 Gobo 6			63 Slow
		045-052 Color 6		37-45 Gobo 5		0-127 Preset	0-127 Preset
0-127	4 Fast	038-044 Color 5	0-15 Stop	28-36 Gobo 4	0-15 Stop		
	0-3 Stop	030-037 Color 4		19-27 Gobo 3			4 Fast
		023-029 Color 3		10-18 Gobo 2			0-3 Stop
		015-022 Color 2		0-9 Gobo 1			
		008-014 Color 1					
		000-007 White					

11channels mode:

DMX 512 Configuration

CH1	CH2	CH3	CH4	CH5	CH6
Dimmer/ Strobe	Moon Flower Moment	Color	Color Shaking	Gobo	Gobo Shaking
249-255 Open 240-248 Reset 210-239 Open 200-209 Random Strobe 190-199 Open 128-189    100% 0-127  0%	255 Fast  196 Slow 192-195 Stop 191 Fast  132 Slow 128-131 Stop 127 Fast  68 Slow 64-67 Stop 63 Slow  4 Fast 0-3 Stop	255 Fast  192 Slow 191 Fast  128 Slow 120-127 Color 16 113-119 Color 15 105-112 Color 14 098-104 Color 13 090-097 Color 12 083-089 Color 11 075-082 Color 10 068-074 Color 9 060-067 Color 8 053-059 Color 7 045-052 Color 6 038-044 Color 5 030-037 Color 4 023-029 Color 3 015-022 Color 2 008-014 Color 1 000-007 White	255 Fast Shaking With Big Area 136 Slow 135 Fast Shaking With Small Area 16 Slow 0-15 Stop	255 Fast  128 Slow 118-127 Gobo 14 109-117 Gobo 13 100-108 Gobo 12 91-99 Gobo 11 82-90 Gobo 10 73-81 Gobo 9 64-72 Gobo 8 55-63 Gobo 7 46-54 Gobo 6 37-45 Gobo 5 28-36 Gobo 4 19-27 Gobo 3 10-18 Gobo 2 0-9 Gobo 1	255 Fast Shaking With Big Area 136 Slow 135 Fast Shaking With Small Area 16 Slow 0-15 Stop
CH7	CH8	CH9	CH10	CH11	
Pan Movement	Tilt Movement	Macro	Pan Speed	Color / Gobo Speed	
255 Fast Shaking With Big Area 192 Slow 191 Fast Shaking With Small Area 128 Slow 0-127 Preset	255 Fast Tilt Shaking With Big Area 196 Slow 192-195 Stop 191 Fast Tilt Shaking With Small Area 132 Slow 128-131 Stop 127 Fast  68 Slow 64-67 Stop 63 Slow  4 Fast 0-3 Stop	240-255 Macro 15 224-239 Macro 14 208-223 Macro 13 192-207 Macro 12 176-191 Macro 11 160-175 Macro 10 144-159 Macro 9 128-143 Macro 8 112-127 Macro 7 96-111 Macro 6 80-95 Macro 5 64-79 Macro 4 48-63 Macro 3 32-47 Macro 2 16-31 Macro 1 0-15 Stop	255 Slow  0 Fast	255 Slow  0 Fast	

5.5 DMX512 connection

The DMX 512 is widely used in intelligent lightings and with a maximum of 512 channels.

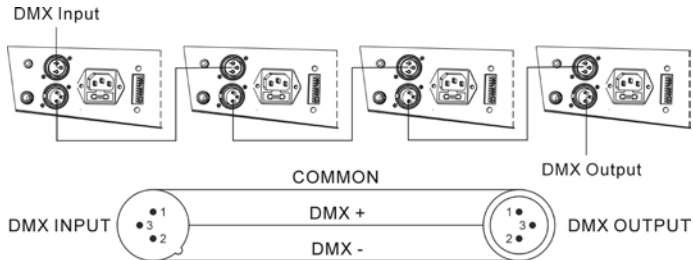

Termination reduces signal errors and to avoid signal transmission problems and interference. It is always advisable to connect a DMX terminal. (Resistance 120 ohm 1/4W) between pin2(DMX-) and pin3(DMX+) of the last fixture.

- 1.If you using a controller with 5 pins DMX output, you need to use a 5 to 3 pin adapter-cable.
 - 2.At last unit, the DMX cable has to be terminated with a terminator. Solder a 120 ohm 1/4W resistor between pin 2(DMX-) and pin 3(DMX+) into a 3-pin XLR-plug and plug it in the DMX-output of the last unit.
 - 3.Connect the unit together in a 'daisy chain' by XLR plug from the output of the unit to the input of the next unit. The cable can not be branched or split to a 'Y' cable. DMX 512 is a very high-speed signal. Inadequate or damaged cables, solder joints or corroded connectors can easily distort the signal and shut down the system.
 - 4.The DMX output and input connectors are pass-through to maintain the DMX circuit, when power is connected to the unit.
 - 5.Each lighting unit needs to have an address set to receive the data sent by the controller. The address number is between 0-512 (usually 0 & 1 are equal to 1).
 - 6.The end of the DMX 512 system should be terminated to reduce signal errors.
- 7.3 pin XLR connectors are more popular than 5 pin XLR.
- 3 pin XLR: Pin 1: GND, Pin 2: Negative signal (-), Pin 3: Positive signal (+)
 - 5 pin XLR: Pin 1: GND, Pin 2: Negative signal (-), Pin 3: Positive signal (+)
Pin 4/5: Not used.

6. Troubleshooting

Following are a few common problems that may occur during operation. Here are some suggestions for easy troubleshooting:

A. The fixture does not work, no light

1. Check the connection of power and main fuse.
2. Measure the mains voltage on the main connector.

B. Not responding to DMX controller

1. DMX LED should be on. If not, check DMX connectors, cables to see if link properly.
2. If the DMX LED is on and no response to the channel, check the address settings and DMX polarity.
3. If you have intermittent DMX signal problems, check the pins on connectors or on PCB of the fixture or the previous one.
4. Try to use another DMX controller.
5. Check if the DMX cables run near or run alongside to high voltage cables that may cause damage or interference to DMX interface circuit.

C. Some fixtures don't respond to the easy controller

1. You may have a break in the DMX cabling.
2. Wrong DMX address in the fixture. Set the proper address.

D. No response to the sound

1. Make sure the fixture does not receive DMX signal.
2. Check microphone to see if it is good by tapping the microphone.

E. One of the channels is not working well

1. The stepper motor might be damaged or the cable connected to the PCB is broken.
2. The motor's drive IC on the PCB might be out of condition.

F. The lamp is cutting out intermittently

1. The lamp is not working well. Check the main voltage either too high or too low.
2. Internal temperature may be too high. Check and if necessary replace the fan.

7. Fixture cleaning

The cleaning of internal and external optical lenses and/or mirrors must be carried out periodically to optimize light output. Cleaning frequency depends on the environment in which the fixture operates: damp, smoky or particularly dirty surrounding can cause greater accumulation of dirt on the unit's optics.

- Clean with soft cloth using normal glass cleaning fluid.
- Always dry the parts carefully.
- Clean the external optics at least every 20 days. Clean the internal optics at least every 30/60 days.

EC - Declaration of Conformity

We declare that our products (lighting equipments) comply with the following specification and bears CE mark in accordance with the provision of the Electromagnetic Compatibility (EMC) Directive 89/336/EEC.

EN55014-2: 1997 A1: 2001, EN61000-4-2: 1995; EN61000-4-3: 2002;

EN61000-4-4: 1995; EN61000-4-5: 1995, EN61000-4-6: 1996,
EN61000-4-11: 1994.

&

Harmonized Standard

EN60598-1: 2000+ALL: 2000+A12: 2002

Safety of household and similar electrical appliances

Part 1: General requirements

Innovation , Quality , Performance