

LEDJ

150W COB RGBL

Zoom Par

User Manual



Order code: LEDJ379

WARNING**FOR YOUR OWN SAFETY, PLEASE READ THIS USER MANUAL CAREFULLY BEFORE YOUR INITIAL START-UP!**

- Before your initial start-up, please make sure that there is no damage caused during transportation.
- Should there be any damage, consult your dealer and do not use the equipment.
- To maintain the equipment in good working condition and to ensure safe operation, it is necessary for the user to follow the safety instructions and warning notes written in this manual.
- Please note that damages caused by user modifications to this equipment are not subject to warranty.

**IMPORTANT:**

The manufacturer will not accept liability for any resulting damages caused by the non-observance of this manual or any unauthorised modification to the equipment.

- Never let the power cable come into contact with other cables. Handle the power cable and all mains voltage connections with particular caution!
- Never remove warning or informative labels from the unit.
- Do not open the equipment and do not modify the unit.
- Do not connect this equipment to a dimmer pack.
- Do not switch the equipment on and off in short intervals, as this will reduce the system's life.
- Only use the equipment indoors.
- Do not expose to flammable sources, liquids or gases.
- Always disconnect the power from the mains when equipment is not in use or before cleaning! Only handle the power-cable by the plug. Never pull out the plug by pulling the power-cable.
- Make sure that the available mains supply voltage is between 100~240V AC, 50/60Hz.
- Make sure that the power cable is never crimped or damaged. Check the equipment and the power cable periodically.
- If the equipment is dropped or damaged, disconnect the mains power supply immediately and have a qualified engineer inspect the equipment before operating again.
- If the equipment has been exposed to drastic temperature fluctuation (e.g. after transportation), do not connect power or switch it on immediately. The arising condensation might damage the equipment. Leave the equipment switched off until it has reached room temperature.
- If your product fails to function correctly, stop use immediately. Pack the unit securely (preferably in the original packing material), and return it to your Pro Light dealer for service.
- Only use fuses of same type and rating.
- Repairs, servicing and power connection must only be carried out by a qualified technician. THIS UNIT CONTAINS NO USER SERVICEABLE PARTS.
- This lighting fixture is for professional use only - it is not designed for or suitable for household use. The product must be installed by a qualified technician in accordance with local territory regulations. The safety of the installation is the responsibility of the installer. The fixture presents risks of severe injury or death due to fire hazards, electric shock and falls.
- Warning! Risk Group 2 LED product according to EN 62471. Do not view the light output with optical instruments or any device that may concentrate the beam.
- WARRANTY: One year from date of purchase.

OPERATING DETERMINATIONS

If this equipment is operated in any other way, than those described in this manual, the product may suffer damage and the warranty becomes void. Incorrect operation may lead to danger e.g: short-circuit, burns and electric shocks etc.

Do not endanger your own safety and the safety of others!

Incorrect installation or use can cause serious damage to people and/or property.

Please note: These fixtures are intended for stage lighting and entertainment applications only, and are not intended for extended periods of use, including but not limited to house-light, industrial or architectural applications and should only be operated with short duty cycles.

150W COB RGLB Zoom Par

The LEDJ 150W COB RGLB Zoom Par delivers a punchy, high-quality wash output powered by an advanced 150W RGLB COB LED. Designed for stages, studios, theatres, and event spaces, this fixture offers ultra-smooth colour mixing with no colour shadows, ensuring flawless results in any lighting setup. Its manually adjustable zoom range of 9° - 30° gives you the flexibility to transition from tight, focused beams to wide, immersive washes. With impressive brightness, this fixture excels in both short and long-throw applications. Featuring a user-friendly 4 button OLED interface, the Zoom Par offers immediate access to built-in colour macros, dimming modes, standalone and sound-active programs, and multiple DMX configurations. Its selectable refresh rates ensure flicker-free operation for TV and camera work, while W-DMX USB compatibility enables cable-free control for modern, flexible rigging environments.



- 1 x 150W quad-colour COB LED (RGLB)
- Adjustable beam angle: 9° - 30°
- 9° 8,543 Lux @ 2m (full on)
- 30° 3,168 Lux @ 2m (full on)
- CRI: 80
- Refresh rate: 1.2kHz-10kHz (5 presets)
- DMX channels: 2/4/4/5/6/7 or 11 selectable
- Manual and primary/secondary modes plus built-in programs
- Colour temperature presets
- 0 - 100% dimming
- Variable strobe
- 4 dimming curves: Linear, square law, inverse square law, S-curve
- Bracket allows for multiple rigging or floor standing applications

- Quick release omega clamp included
- 4 button menu with OLED display
- PowerTwist TR1 input/output
- 5-Pin XLR input/output
- 3-Pin XLR input/output
- Fan cooled

Beam Angle	9°	15°	22.5°	30°
9° LUX	3096	2319	1064	268
30° LUX	3244	811	360	203
9° LUX	20204	9051	2040	1263
30° LUX	7676	1919	853	480
9° LUX	3820	855	424	230
30° LUX	1452	363	161	91
9° LUX	29960	6490	2884	1623
30° LUX	9932	2483	1104	621
9° LUX	34172	8543	3797	2136
30° LUX	12672	3168	1408	792

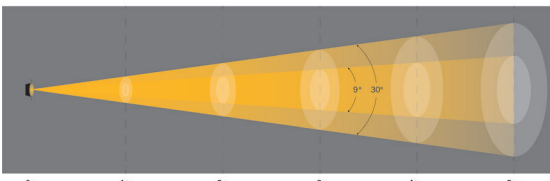

Specifications	150W RGLB COB Zoom Par
Power consumption	154W
Power supply	100~240V, 50/60Hz
Fuse	T5A 250V
Dimensions	450 x 270 x 195mm
Weight	5kg
Order codes	LEDJ379

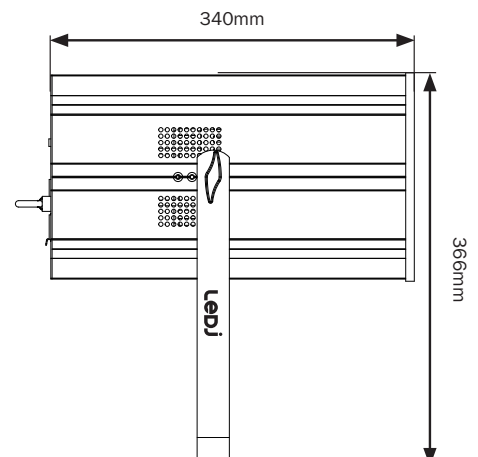
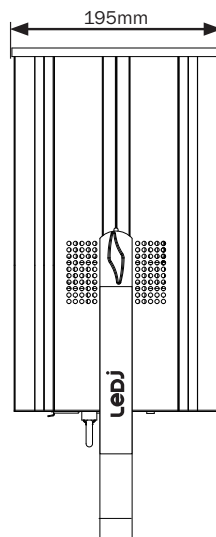
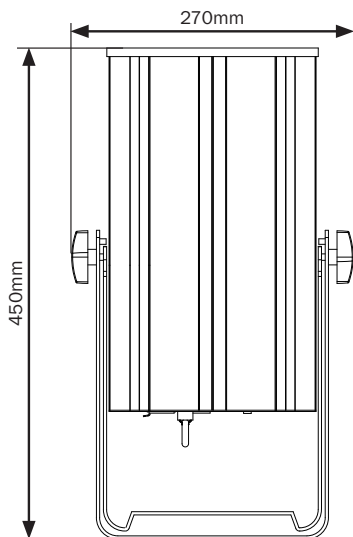

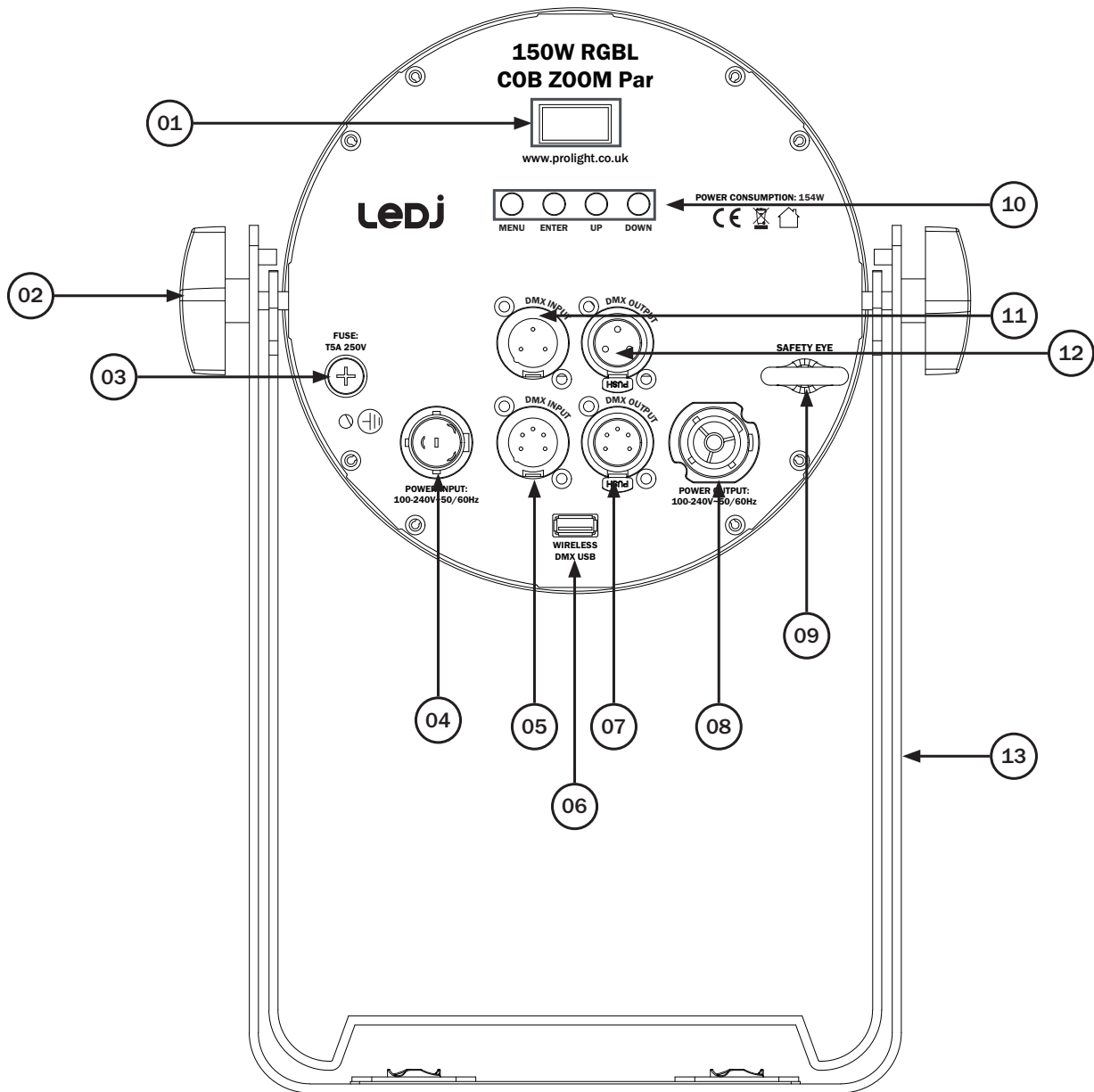

- 01 - OLED display
- 02 - Hanging bracket adjustable knob
- 03 - Fuse: F5A 250V
- 04 - PowerTwist TR1 input
- 05 - 5-Pin XLR DMX input
- 06 - USB port
- 07 - 5-Pin XLR DMX output

- 08 - PowerTwist TR1 output
- 09 - Safety eye
- 10 - Function buttons
- 11 - 3-Pin XLR DMX input
- 12 - 3-Pin XLR DMX output
- 13 - Hanging bracket

In the box: **1 x fixture,**
1 x omega clamp &
1 x power cable

Installation:

1. Fasten each clamp to the omega clamp with a bolt and lock nut through the hole in the omega clamp.
2. Align and insert the omega clamp quick-lock fasteners with the respective holes on the bracket of the unit.
3. Tighten both locking fasteners clockwise on each omega clamp ensuring they're fully secure.
4. Mount the fixture onto your truss system via the clamps and tighten to ensure that it's secure.
5. Pull the safety cable through the safety cable holes located on the metal base plate on the underside of the fixture and around the truss.

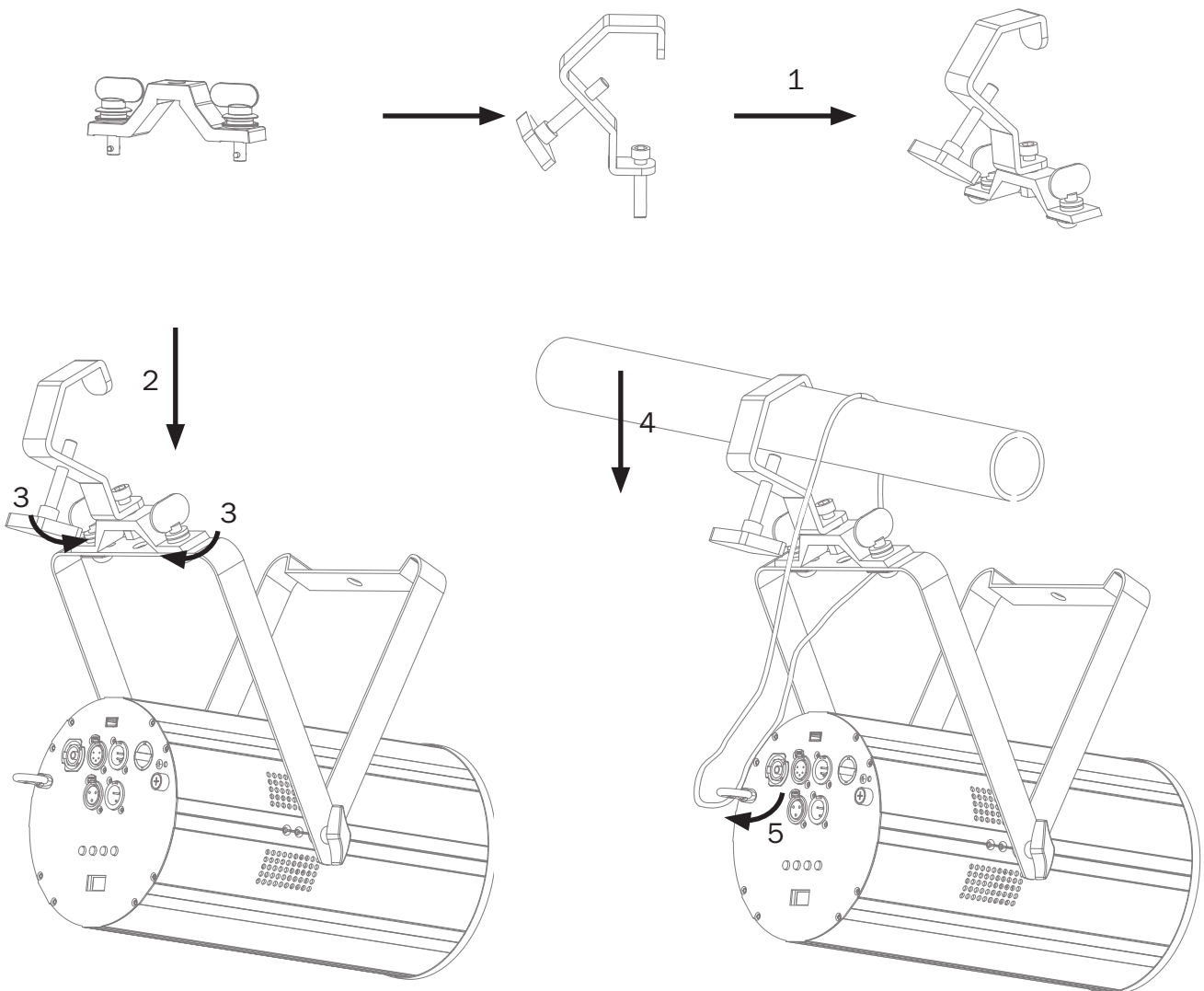

Main Menu	Sub Menu	Options/Values (Default Settings in BOLD)		Description	
DMX setting	Address	001-512		DMX Address Setting	
	Channel Mode	2CH (02 channel mode)		Channel Mode Setting	
		4CHA (04 channel mode)			
		4CHB (04 channel mode)			
		5CH (05 channel mode)			
		6CH (06 channel mode)			
		07CH (07 channel mode)			
	No DMX status	Hold Last		DMX Fail Setting	
		Blackout			
		Manual Settings			
Internal Programs					
Personality	DimMode	LED		Dimming Mode	
		Halogen			
	Dim_Curve	Linear		Dimming Curves Setting	
		Square			
		Inv.Squa			
		S.Curve			
	Wireless	ON/ OFF		Wireless Setting	
	LED Refresh	1200Hz		Refresh Rate Setting	
		2400Hz			
		4000Hz			
6000Hz					
10000Hz					
RDM	ON/ OFF		Remote Device Management		
Display	Screen Saver Delay	OFF, 1- 10 sec.		Display Setting	
	Rotate Display 180°	YES/ NO			
Factory Restore	YES/ NO		Factory Reset		
Manual Control	Red	000-255		Manual Control Setting	
	Green	000-255			
	Blue	000-255			
	Lime	000-255			
	Colour Macros	000-023			
	Strobe	000-255			
	Master Dimmer	000-255			
Internal Programs	Program 0	Speed	1-255		Internal Programs
		Fade	0-255		
		Sound	ON/ OFF	001-016	
			
	Program 13	Speed	1-255		
		Fade	0-255		
Sound		ON/ OFF	001-016		

Main Menu	Sub Menu	Options/Values (Default Settings in BOLD)	Description
Information	LED Temperature	xxx F / xxx C	Temperature Information
	Software Version	x.xx	Software Version
	Fixture Hours	xxxxxxH	Runtime Information
Slave Mode	Slave Mode		Primary/Secondary Mode

DMX channel modes:

Channel							Value	Function		
2CH	4CHA	4CHB	5CH	6CH	7CH	11CH				
-	-	1	1	-	1	1	000-255	Red dimmer (0-100%)		
-	-	2	2	-	2	2	000-255	Green dimmer (0-100%)		
-	-	3	3	-	3	3	000-255	Blue dimmer (0-100%)		
-	-	4	4	-	4	4	000-255	Lime dimmer (0-100%)		
-	-	-	-	1	5	5	000-031	No function		
							032-063	LED on		
							064-095	Strobe (slow-fast)		
							096-127	LED on		
							128-159	Strobe pulse (slow-fast)		
							160-191	LED on		
							192-223	Strobe random (slow-fast)		
							224-255	LED on		
1	1	-	5	2	6	6	000-255	Master dimmer (0-100%)		
-	2	-	-	3	-	7	000-051	No function		
							052-102	Colour macro mode (CH8)		
							103-153	Colour change mode		
							154-204	Colour fade mode		
							205-255	Sound active mode		
-	3	-	-	4	-	8	000-018	Colour Change 1	000-005 No function	Colour macros (when CH2, CH3 or CH7 are between 052-102)
								Colour Fade 1		
								Sound Active 1		
							019-037	Colour Change 2		
								Colour Fade 2		
								Sound Active 2		
							038-056	Colour Change 3		
								Colour Fade 3		
								Sound Active 3		
							057-075	Colour Change 4		
								Colour Fade 4		
								Sound Active 4		
							076-093	Colour Change 5		
								Colour Fade 5		
								Sound Active 5		
							094-111	Colour Change 6		
								Colour Fade 6		
								Sound Active 6		
							112-129	Colour Change 7		
								Colour Fade 7		
								Sound Active 7		

DMX channel modes:

Channel							Value	Function											
2CH	4CHA	4CHB	5CH	6CH	7CH	11CH													
-	3	-	-	4	-	8	130-147	Colour Change 8	000-005 No function	Colour macros (when CH2, CH3 or CH7 are between 052-102)									
								Colour Fade 8											
								Sound Active 8											
								148-165			Colour Change 9								
											Colour Fade 9								
											Sound Active 9								
								166-183			Colour Change 10								
											Colour Fade 10								
											Sound Active 10								
							184-201	Colour Change 11											
								Colour Fade 11											
								Sound Active 11											
							202-219	Colour Change 12											
								Colour Fade 12											
								Sound Active 12											
							220-237	Colour Change 13											
								Colour Fade 13											
								Sound Active 13											
							238-255	Colour Change 14											
								Colour Fade 14											
								Sound Active 14											
							-	4			-	-	5	-	9	000-255	No function (CH7 value 000-102)		
																	Speed (slow-fast) (CH7 value 103-204)		
																	Sensitivity (low-high) (CH7 value 205-255)		
-	-	-	-	-	7	10	000-13	No function											
							014-28	Dimming Mode Set in Menu (hold 3s)											
							029-43	Halogen Dimming Mode (hold 3s)											
							044-58	LED Dimming Mode (hold 3s)											
							059-73	No function											
							074-88	Dimming Curve Set in Menu (hold 3s)											
							89-103	Linear (hold 3s)											
							104-118	Square Law (hold 3s)											
							119-133	Inverse Square (hold 3s)											
							134-148	S-Curve (hold 3s)											
							149-163	No function											
							164-178	Refresh Rate Set in Menu (hold 3s)											
							179-193	1200Hz (hold 3s)											
							194-208	2400Hz (hold 3s)											
							209-223	4000Hz (hold 3s)											

DMX channel modes:

Channel							Value	Function
2CH	4CHA	4CHB	5CH	6CH	7CH	11CH		
-	-	-	-	-	7	10	224-238	6000Hz (hold 3s)
							239-253	10kHz (hold 3s)
							254-255	No function
2	-	-	-	6	-	11	000	No function
							001-255	Colour temperature 1800K-10,000K

Setting the DMX address:

The DMX mode enables the use of a universal DMX controller. Each fixture requires a “start address” from 1- 512. A fixture requiring one or more channels for control begins to read the data on the channel indicated by the start address. For example, a fixture that occupies or uses 7 channels of DMX and was addressed to start on DMX channel 100, would read data from channels: 100, 101, 102, 103, 104, 105 and 106. Choose a start address so that the channels used do not overlap. E.g. the next unit in the chain starts at 107.

DMX 512:

DMX (Digital Multiplex) is a universal protocol used as a form of communication between intelligent fixtures and controllers. A DMX controller sends DMX data instructions from the controller to the fixture. DMX data is sent as serial data that travels from fixture to fixture via the DATA “IN” and DATA “OUT” XLR terminals located on all DMX fixtures (most controllers only have a data “out” terminal).

DMX linking:

DMX is a language allowing all makes and models of different manufactures to be linked together and operate from a single controller, as long as all fixtures and the controller are DMX compliant. To ensure proper DMX data transmission, when using several DMX fixtures try to use the shortest cable path possible. The order in which fixtures are connected in a DMX line does not influence the DMX addressing. For example; a fixture assigned to a DMX address of 1 may be placed anywhere in a DMX line, at the beginning, at the end, or anywhere in the middle. When a fixture is assigned a DMX address of 1, the DMX controller knows to send DATA assigned to address 1 to that unit, no matter where it is located in the DMX chain.

DATA cable (DMX cable) requirements (for DMX operation):

This fixture can be controlled via DMX-512 protocol. The DMX address is set on the back of the unit. Your unit requires either a standard 3-pin or 5-pin XLR connector for data input/output, see images below.



Further DMX cables can be purchased from all good sound and lighting suppliers or Prolight Concepts dealers.					
Please quote:	3-Pin:	CABL10 - 2m	CABL11 - 5m	CABL12 - 10m	
	5-Pin:	CABL185 - 2m	CABL187 - 5m	CABL188 - 10m	

Also remember that DMX cable must be daisy chained and cannot be split.

Notice:

Be sure to follow the diagrams below when making your own cables. Do not connect the cables shield conductor to the ground lug or allow the shield conductor to come in contact with the XLRs outer casing. Grounding the shield could cause a short circuit and erratic behaviour.

Pin Configuration	
3-Pin	5-Pin
	Pin 1 - Ground
	Pin 2 - Negative
	Pin 3 - Positive
-	Pin 4 - N/C
-	Pin 5 - N/C

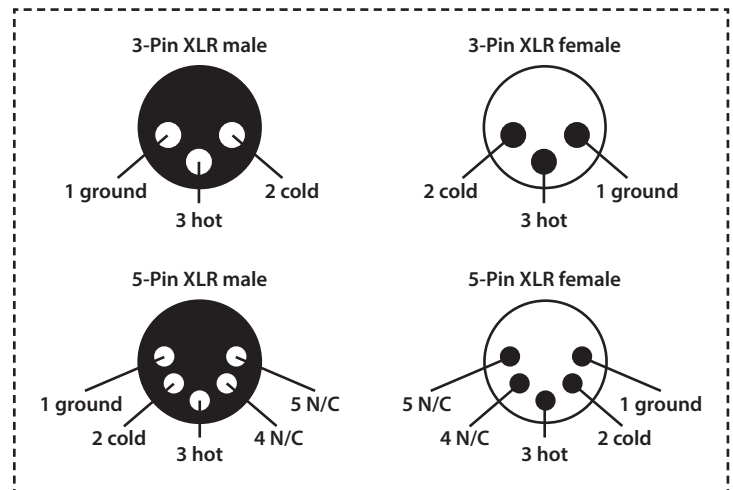
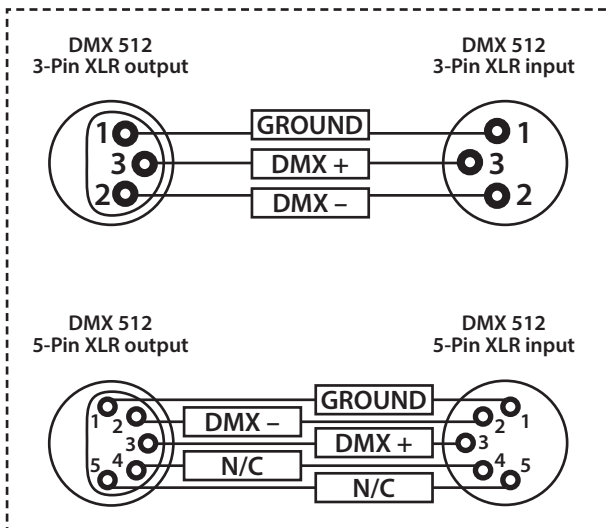

Line termination:

When longer runs of cable are used, you may need to use a terminator on the last unit to avoid erratic behaviour.

Using a cable terminator will decrease the possibilities of erratic behaviour.

(3-pin - Order ref: CABL90,
5-pin - Order ref: CABL89)

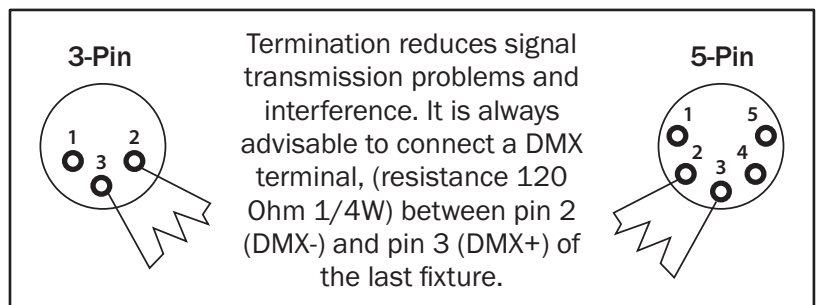

5-pin XLR DMX connectors:

Some manufactures use 5-pin XLR connectors for data transmission in place of 3-pin. 5-pin XLR fixtures may be implemented in a 3-pin XLR DMX line. When inserting standard 5-pin XLR connectors in to a 3-pin line a cable adaptor must be used. The diagram below details the correct cable conversion.

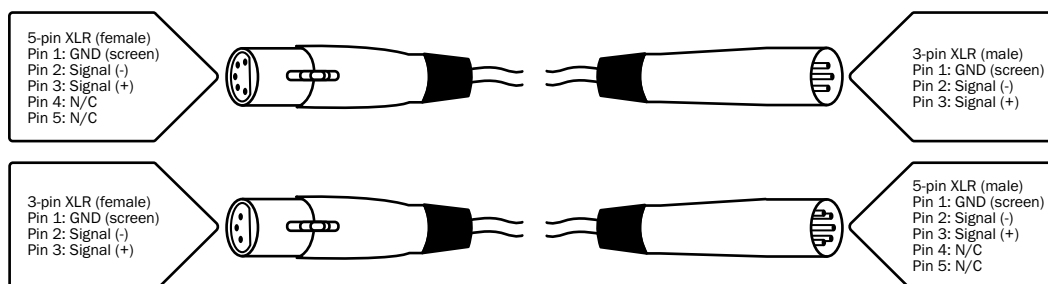

Power linking:

This fixture provides power linking via the power output on the rear allowing multiple units to be connected together. The maximum number of fixtures that can be connected is 5 fixtures @ 240V or 2 fixtures @ 120V (including the first fixture). After the maximum number of fixtures are connected a new power run will need to be started.

Please note: Caution should be used when power linking other fixtures to the 150W RGLB COB Zoom Par as the power consumption of other fixtures will vary. Fixtures fitted with lamps often require 2/3 times more current on startup, these may require their own power source.

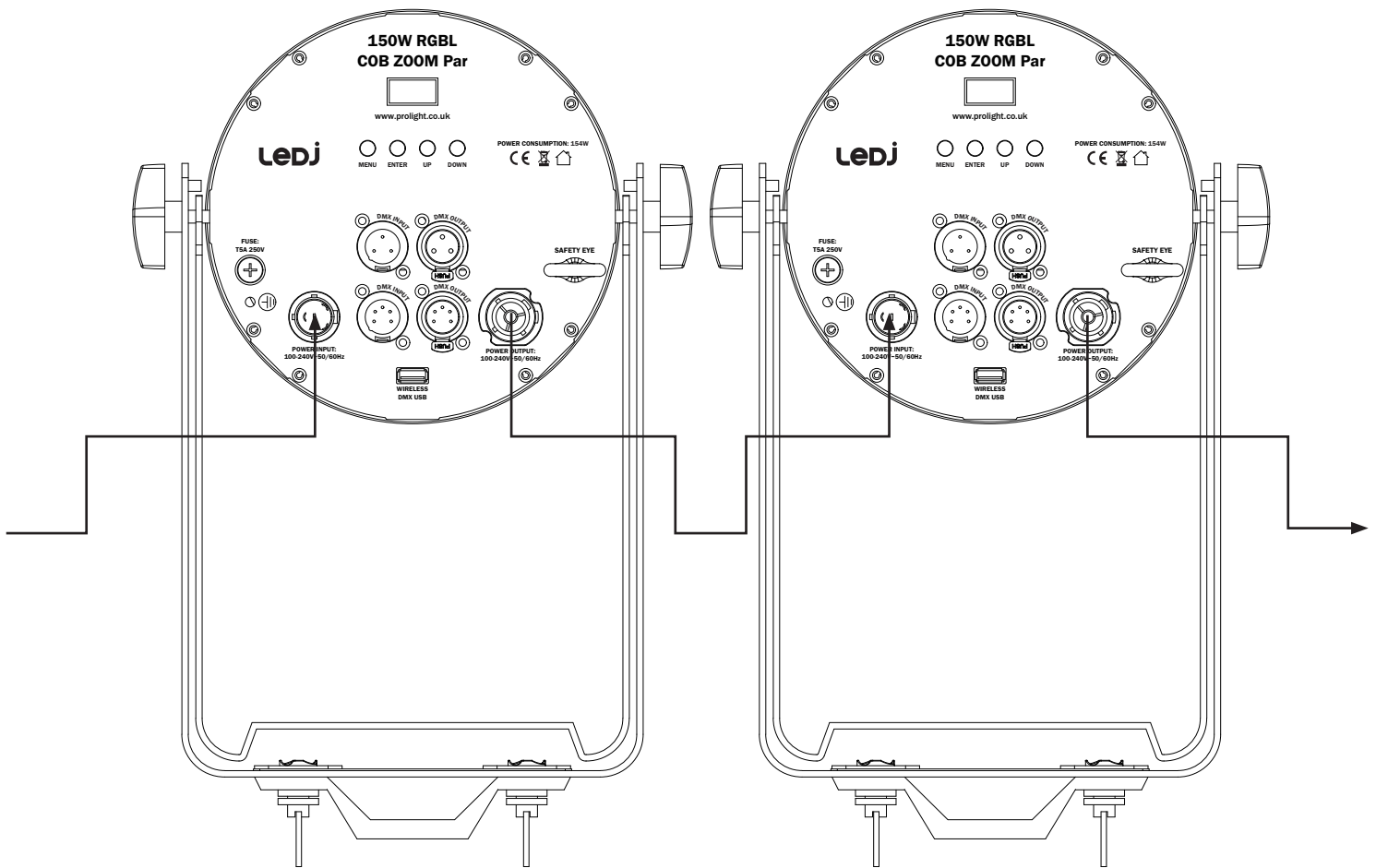



***Correct Disposal of this Product
(Waste Electrical & Electronic Equipment)***

(Applicable in the European Union and other European countries with separate collection systems)

This marking shown on the product or its literature, indicates that it should not be disposed with other household wastes at the end of its working life. To prevent possible harm to the environment or human health from uncontrolled waste disposal, please separate this from other types of wastes and recycle it responsibly to promote the sustainable reuse of material resources.

Household users should contact either the retailer where they purchased this product, or their local government office, for details of where and how they can take this item for environmentally safe recycling.

Business users should contact their supplier and check the terms and conditions of the purchase contract. This product should not be mixed with other commercial wastes for disposal.

