



Slimline 12HEX12
12 x 12W six-colour LEDs
(RGBAWUV)
User Manual



Optional
IR remote
Order ref:
LEDJ90F

Order codes: LEDJ84

WARNING

FOR YOUR OWN SAFETY, PLEASE READ THIS USER MANUAL CAREFULLY BEFORE YOUR INITIAL START-UP!

- Before your initial start-up, please make sure that there is no damage caused during transportation.
- Should there be any damage, consult your dealer and do not use the equipment.
- To maintain the equipment in good working condition and to ensure safe operation, it is necessary for the user to follow the safety instructions and warning notes written in this manual.
- Please note that damages caused by user modifications to this equipment are not subject to warranty.



IMPORTANT:

The manufacturer will not accept liability for any resulting damages caused by the non-observance of this manual or any unauthorised modification to the equipment.

- Never let the power cable come into contact with other cables. Handle the power cable and all mains voltage connections with particular caution!
- Never remove warning or informative labels from the unit.
- Do not open the equipment and do not modify the unit.
- Do not connect this equipment to a dimmer pack.
- Do not switch the equipment on and off in short intervals, as this will reduce the system's life.
- Only use the equipment indoors.
- Do not expose to flammable sources, liquids or gases.
- Always disconnect the power from the mains when equipment is not in use or before cleaning! Only handle the power-cable by the plug. Never pull out the plug by pulling the power-cable.
- Make sure that the available voltage is between 100~240V, 50/60Hz.
- Make sure that the power cable is never crimped or damaged. Check the equipment and the power cable periodically.
- If the equipment is dropped or damaged, disconnect the mains power supply immediately and have a qualified engineer inspect the equipment before operating again.
- If the equipment has been exposed to drastic temperature fluctuation (e.g. after transportation), do not connect power or switch it on immediately. The arising condensation might damage the equipment. Leave the equipment switched off until it has reached room temperature.
- If your product fails to function correctly, stop use immediately. Pack the unit securely (preferably in the original packing material), and return it to your Pro Light dealer for service.
- Only use fuses of same type and rating.
- Repairs, servicing and power connection must only be carried out by a qualified technician. THIS UNIT CONTAINS NO USER SERVICEABLE PARTS.
- WARRANTY: One year from date of purchase.

OPERATING DETERMINATIONS

If this equipment is operated in any other way, than those described in this manual, the product may suffer damage and the warranty becomes void. Incorrect operation may lead to danger e.g: short-circuit, burns and electric shocks etc.

Do not endanger your own safety and the safety of others!

Incorrect installation or use can cause serious damage to people and/or property.

Slimline 12HEX12

Housing 12 x 12W six-colour LEDs, the Slimline 12HEX12 gives smooth colour mixing from rich saturated hues to subtle pastel shades. These units have a rugged, all metal housing and measure only 115mm in depth for easy transportation and installation. The 4 push button LED menu or supplied IR remote allow easy access to the functions including DMX, master/slave and sound active.

- 12 x 12W six-colour LEDs (RGBWAUV)
- Beam angle: 35° (field angle: 65°)
- 1.2kHz refresh rate
- DMX channels: 2/3/3/4/4/5/6 or 9 selectable
- Static colour, colour change, colour fade, auto run, sound active and master/slave modes
- 0 - 100% dimming and variable strobe
- Bracket allows for multiple rigging or floor standing applications
- Rubber feet allow the panel to sit flat on the floor for uplighting
- 4 push button menu with LED display
- Side entry XLR and power connections
- IEC power input/output
- 3-Pin XLR input/output
- Fan cooled
- Optional IR remote (LEDJ90F)

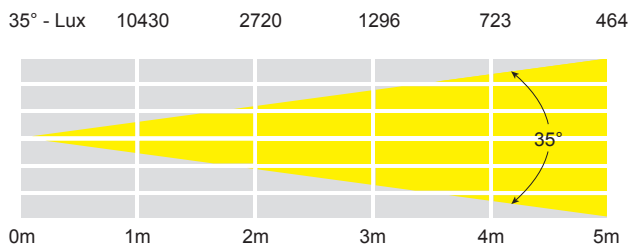

Specifications	Slimline 12HEX12
Power consumption	144W
Power supply	100~240V, 50/60Hz
Fuse	T1A 250V
Dimensions	280 x 248 x 120mm
Weight	3.8kg
Order code	LEDJ84

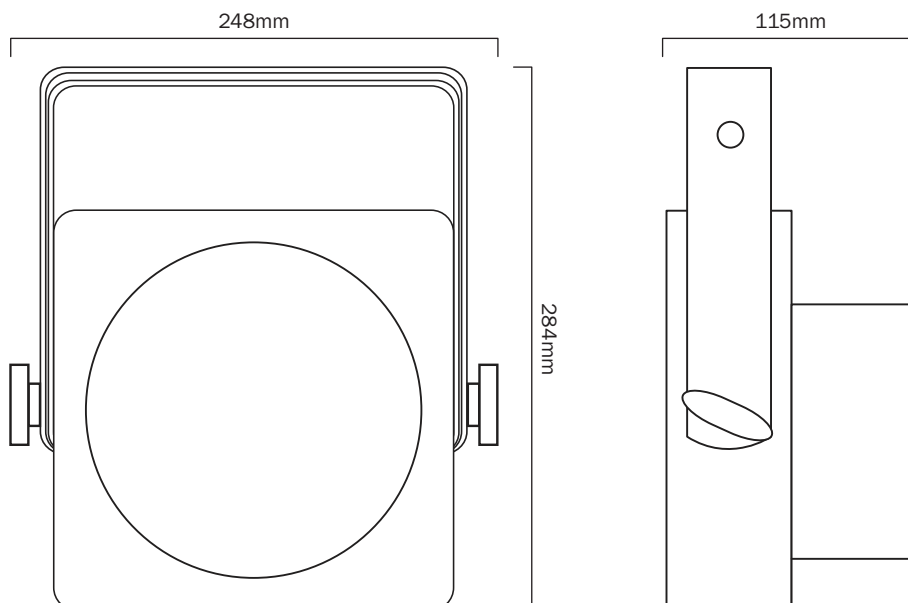

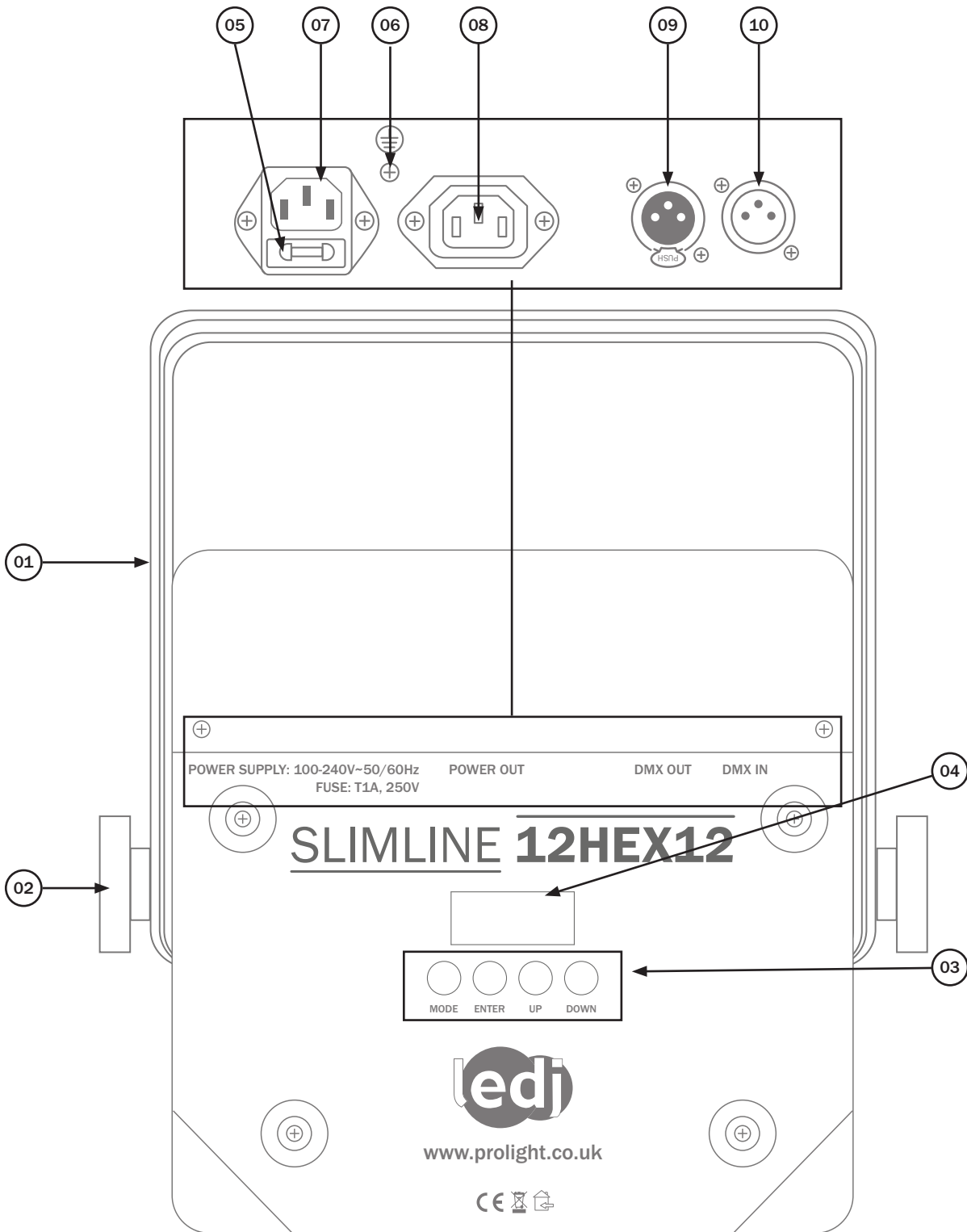

01 - Bracket

02 - Bracket tightening knobs

03 - Function buttons

04 - LED display

05 - Fuse T1A 250V

06 - Earth point

07 - IEC power input

08 - IEC power output

09 - 3-Pin DMX output

10 - 3-Pin DMX input

In the box: **1 x fixture,**
1 x power cable &
1 x user manual

DMX channel mode:

Operating in a DMX control mode environment gives the user the greatest flexibility when it comes to customising or creating a show. In this mode you will be able to control each individual trait of the fixture and each fixture independently.

To access the DMX channel mode, press the “**MODE**” button on the rear of the unit to show - [H on the LED display. Now press the “**ENTER**” button and use the “**UP**” and “**DOWN**” buttons to set the desired DMX address. Now press the “**ENTER**” button to choose one of the 2, 3, 3, 4, 4, 5, 6 or 9 DMX channel modes. Use the “**UP**” and “**DOWN**” buttons, and press the “**ENTER**” button to confirm the setting. To exit out of any of the above options, press the “**MODE**” button.

2 channel mode:

Channel	Value	Function
1	000-255	Master dimmer (0-100%)
2 000-255 colour macro	000-016	Red
	017-033	Green
	034-050	Blue
	051-067	White
	068-084	Amber
	085-101	UV
	102-118	Yellow (R - 255, G - 200, A - 255)
	119-135	Cyan (G - 255, B - 255)
	136-152	Lavender (R - 170, B - 210)
	153-169	Bright green (G - 255, A - 180)
	170-186	Magenta (R - 255, B - 90, UV - 255)
	187-203	Turquoise (G - 255, B - 180, UV - 255)
	204-220	Orange (R - 200, A - 200)
	221-237	Cool white (R - 70, G - 190, B - 255, A - 200)
238-255	Warm white (R - 230, G - 255, B - 255, A - 255, W - 255)	

3 channel mode 1:

Channel	Value	Function
1	000-255	Master dimmer (0-100%)
2	000-255	Flash (speed 0-100%, 1Hz-20Hz)
3	000-004	Blackout
	005-010	Red
	011-015	Green
	016-020	Blue
	021-025	White
	026-030	Amber
	031-035	UV
	036-040	Yellow (R - 255, G - 200, A - 255)
	041-045	Cyan (G - 255, B - 255)
	046-050	Lavender (R - 170, B - 210)
	051-055	Bright green (G - 255, A - 180)
	056-060	Magenta (R - 255, B - 90, UV - 255)
	061-065	Turquoise (G - 255, B - 180, UV - 255)
	066-070	Orange (R - 200, A - 200)
	071-075	Cool white (R - 70, G - 190, B - 255, A - 200)
	076-080	Warm white (R - 230, G - 255, B - 255, A - 255, W - 255)
081-150	Colour change speed Slowest (081) changes every 8 secs Fastest (150) changes every 0.3 secs	
151-220	Colour fade speed Slowest (151) changes every 8 secs Fastest (220) changes every 0.3 secs	
221-255	Sound control (mic sensitivity)	

3 channel mode 2:

Channel	Value	Function
1	000-255	Red (0-100%)
2	000-255	Green (0-100%)
3	000-255	Blue (0-100%)

4 channel mode 1:

Channel	Value	Function
1	000-255	Red (0-100%)
2	000-255	Green (0-100%)
3	000-255	Blue (0-100%)
4	000-255	White (0-100%)

4 channel mode 2:

Channel	Value	Function
1	000-255	Red (0-100%)
2	000-255	Green (0-100%)
3	000-255	Blue (0-100%)
4	000-255	Amber (0-100%)

5 channel mode:

Channel	Value	Function
1	000-255	Red (0-100%)
2	000-255	Green (0-100%)
3	000-255	Blue (0-100%)
4	000-255	White (0-100%)
5	000-255	Amber (0-100%)

6 channel mode:

Channel	Value	Function
1	000-255	Red (0-100%)
2	000-255	Green (0-100%)
3	000-255	Blue (0-100%)
4	000-255	White (0-100%)
5	000-255	Amber (0-100%)
6	000-255	UV (0-100%)

9 channel mode:

Channel	Value	Function
1	000-255	Master dimmer (0-100%)
2	000-255	Flash (speed 0-100%, 1Hz-20Hz)
3	000-255	Red (0-100%)
4	000-255	Green (0-100%)
5	000-255	Blue (0-100%)
6	000-255	White (0-100%)
7	000-255	Amber (0-100%)
8	000-255	UV (0-100%)
9	000-004	Blackout
	005-010	Red
	011-015	Green
	016-020	Blue
	021-025	White
	026-030	Amber
	031-035	UV
	036-040	Yellow (R - 255, G - 200, A - 255)
	041-045	Cyan (G - 255, B - 255)
	046-050	Lavender (R - 170, B - 210)
	051-055	Bright green (G - 255, A - 180)
	056-060	Magenta (R - 255, B - 90, UV - 255)
	061-065	Turquoise (G - 255, B - 180, UV - 255)
	066-070	Orange (R - 200, A - 200)
	071-075	Cool white (R - 70, G - 190, B - 255, A - 200)
	076-080	Warm white (R - 230, G - 255, B - 255, A - 255, W - 255)
	081-150	Colour change speed Slowest (081) changes every 8 secs Fastest (150) changes every 0.3 secs
151-220	Colour fade speed Slowest (151) changes every 8 secs Fastest (220) changes every 0.3 secs	
221-255	Sound control (mic sensitivity)	

RGBAWUV colour mix mode:

In this mode you can set the fixture to any colour and any brightness.

To access the colour mix mode, press the “**MODE**” button on the rear of the unit to show `Ⓛ 1 - -` with 3 digits after on the LED display. Press the “**ENTER**” button to confirm.

The `Ⓛ 1` represents red, `Ⓛ 2` = green, `Ⓛ 3` = blue, `Ⓛ 4` = white, `Ⓛ 5` = amber, `Ⓛ 6` = UV and `Ⓛ F 0` = strobe. The 2 digits after are the brightness setting from `00 ~ 99`, or the strobe speed if in `Ⓛ F 0`.

For example:

If you set 1, 2, 3, 4, 5 and 6 all to zero, your unit will have no LEDs lit up (blackout).

If you set `Ⓛ 100` to `Ⓛ 199` and 2, 3, 4, 5 and 6 to zero, your unit will show only red LEDs.

Press the “**ENTER**” button to confirm the setting and move to the next colour.

To exit out of any of the above options, press the “**MODE**” button.

Colour fade mode:

To access the colour fade mode press “**ENTER**” until the display shows `FA - -` on the LED display.

To adjust the speed use the “**UP**” and “**DOWN**” buttons to select any value from `FA00 ~ FA99`.

To select the strobe mode press “**ENTER**”, the LED display will change to `FF - -`, using the “**UP**” and “**DOWN**” buttons to select any value from `FF00 ~ FF99`.

Value: 00 - 99 (00 = low, 99 = high)

To exit out of any of the above options, press the “**MODE**” button.

Colour change mode:

To access the colour change mode press “**ENTER**” until `JU - -` shows on the LED display. To adjust the speed use the “**UP**” and “**DOWN**” buttons to select any value from `JA00 ~ JA99`. To select the strobe mode press “**ENTER**”, the display will change to `JF - -`, using the “**UP**” and “**DOWN**” buttons to select any value from `JF00 ~ JF99`.

Value: 00 - 99 (00 = low, 99 = high)

To exit out of any of the above options, press the “**MODE**” button.

Master/slave mode:

To set the master unit, press the “**MODE**” button on the rear of the master unit then select your desired program (sound active, auto, static colour, colour mix or one of the built-in programs).

To set the other units in slave mode, press the “**MODE**” button on the rear of the unit to show `SLAU` on the LED display and press the “**ENTER**” button to confirm the setting. The units will now run in sequence with the master unit.

To exit out of any of the above options, press the “**MODE**” button.

Please ensure that all slave units are set to the same DMX channel mode as the master unit.

Sound active mode:

To access the sound active mode, press the “**MODE**” button on the rear of the unit to show *SUDD* on the LED display. Now press the “**ENTER**” button and use the “**UP**” and “**DOWN**” buttons to set the sound sensitivity level from *SUDD* ~ *SU.99* and press the “**ENTER**” button to confirm the setting.

Value: 00 - 99 (00 = low, 99 = high)

To exit out of any of the above options, press the “**MODE**” button.

Auto run mode:

To access the auto run mode, press the “**MODE**” button to show *AUDD* on the LED display.

The fixture will then automatically scroll through colour fade and colour change. The speed/flash rate is not adjustable.

Press the “**ENTER**” button to confirm the setting.

To exit out of any of the above options, press the “**MODE**” button.

Colour preset mode:

To access the colour preset mode press “**ENTER**” until *Cn - -* shows on the LED display. To adjust the colour use the “**UP**” and “**DOWN**” buttons to select any value from *Cn01* ~ *Cn15*.

Press the “**ENTER**” button to confirm the setting.

To exit out of any of the above options, press the “**MODE**” button.

Menu system

Static colour mode	<i>C100</i> ~ <i>C199</i> R <i>C200</i> ~ <i>C299</i> G <i>C300</i> ~ <i>C399</i> B <i>C400</i> ~ <i>C499</i> W <i>C500</i> ~ <i>C599</i> A <i>C600</i> ~ <i>C699</i> U <i>C700</i> ~ <i>C799</i> Flash
Colour macro mode Cn01-15	<i>Cn01</i> - Red <i>Cn02</i> - Green <i>Cn03</i> - Blue <i>Cn04</i> - White <i>Cn05</i> - Amber <i>Cn06</i> - UV <i>Cn07</i> - Yellow <i>Cn08</i> - Light blue <i>Cn09</i> - Pink <i>Cn10</i> - Light green <i>Cn11</i> - Rose pink <i>Cn12</i> - Peacock blue <i>Cn13</i> - Orange <i>Cn14</i> - Pastel blue/white <i>Cn15</i> - White
Colour changing mode	<i>JUDD</i> ~ <i>JU99</i> (speed) <i>JFDD</i> ~ <i>JF99</i> (flash)
Colour fade mode	<i>FRDD</i> ~ <i>FR99</i> (speed) <i>FFDD</i> ~ <i>FF99</i> (flash)
Auto mode	<i>AU70</i>
Slave mode	<i>SLAU</i>
Sound active mode	<i>SUDD</i> ~ <i>SU99</i>
DMX mode	2CH, 3CH1, 3CH2, 4CH1, 4CH2, 5CH, 6CH, 9CH
Address setting	<i>ADD1</i> ~ <i>AS12</i>

Optional IR remote functions:

Button functions:

- 01 - Sets the fixture into power on or off modes
- 02 - Sets in auto run
- 03 - Runs the built-in programs, use the '+' and '-' buttons to go through the programs
- 04 - Sets the LEDs to flash on and off, use the '+' and '-' buttons to change the flash frequency
- 05 - Sets the run speed, use the '+' and '-' buttons to change the desired speed (note: only available in the colour change or colour fade modes)
- 06 - Sets the fixture into DMX mode
- 07 - Sets the fixture into sound active mode
- 08 - Sets the fixture into slave mode
- 09 - Sets the DMX address for the fixture
- 10 - Sets the LEDs colour, use the '+' and '-' buttons to change the brightness

DMX address examples:

To set the DMX address "245";

- Press the "S" button, the red LEDs will come on, you can now start to set the DMX address
- Now press the "2" button, the green LEDs will come on, this means the first digit has been set at 2
- Now press the "4" button, the blue LEDs will come on, this means the second digit has been set at 4
- Now press the "5" button, and all of the R, G, B, A, W and UV LEDs will come on, the third digit 5 has been set. The full DMX address setting has been changed
- Now press the "DMX MODE" button to save the new address into the memory

Important notes:

- Set the DMX address on each fixture before plugging into the DMX controller
- The IR remote is cannot be used when the fixture(s) are being controlled with a DMX controller
- The maximum IR transmitter distance is 10m - Please make sure that you have the IR remote aimed directly at the front panel of each fixture to be programmed
- If you do not press the "DMX MODE" button after you have changed the DMX address when you power down the fixture it will lose the address you have set

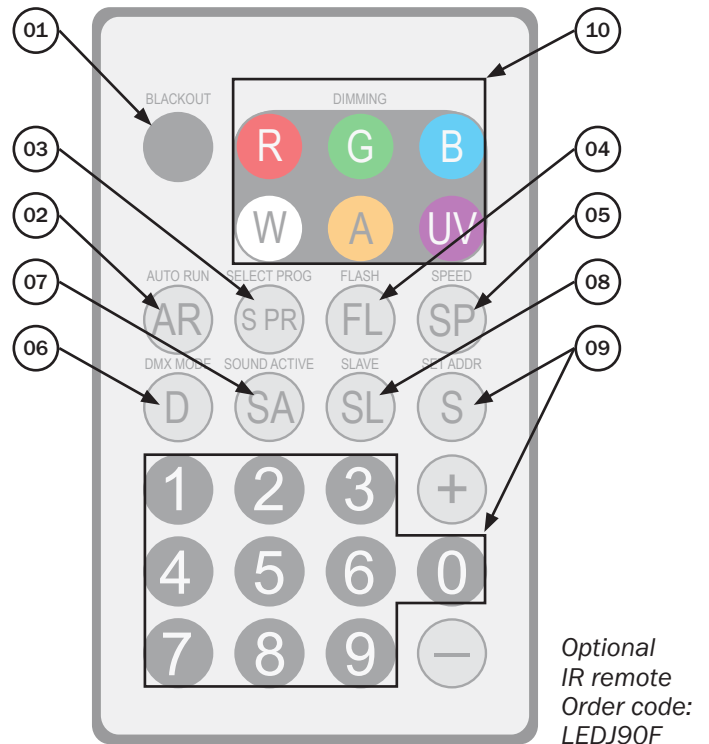

To set the DMX address "002";

- Press the "S" button, the red LEDs will come on, you can now start to set the DMX address
- Now press the "0" button, the green LEDs will come on, this means the first digit has been set at 0
- Now press the "0" button, the blue LEDs will come on, this means the second digit has been set at 0
- Now press the "2" button, and all of the R, G, B, A, W and UV LEDs will come on, the third digit 2 has been set. The full DMX address setting has been changed
- Now press the "DMX MODE" button to save the new address into memory

Setting the DMX address:

The DMX mode enables the use of a universal DMX controller. Each fixture requires a “start address” from 1- 512. A fixture requiring one or more channels for control begins to read the data on the channel indicated by the start address. For example, a fixture that occupies or uses 7 channels of DMX and was addressed to start on DMX channel 100, would read data from channels: 100,101,102,103,104,105 and 106. Choose a start address so that the channels used do not overlap. E.g. the next unit in the chain starts at 107.

DMX 512:

DMX (Digital Multiplex) is a universal protocol used as a form of communication between intelligent fixtures and controllers. A DMX controller sends DMX data instructions from the controller to the fixture. DMX data is sent as serial data that travels from fixture to fixture via the DATA “IN” and DATA “OUT” XLR terminals located on all DMX fixtures (most controllers only have a data “out” terminal).

DMX linking:

DMX is a language allowing all makes and models of different manufactures to be linked together and operate from a single controller, as long as all fixtures and the controller are DMX compliant. To ensure proper DMX data transmission, when using several DMX fixtures try to use the shortest cable path possible. The order in which fixtures are connected in a DMX line does not influence the DMX addressing. For example; a fixture assigned to a DMX address of 1 may be placed anywhere in a DMX line, at the beginning, at the end, or anywhere in the middle. When a fixture is assigned a DMX address of 1, the DMX controller knows to send DATA assigned to address 1 to that unit, no matter where it is located in the DMX chain.

DATA cable (DMX cable) requirements (for DMX operation):

This fixture can be controlled via DMX-512 protocol. The DMX address is set on the back of the unit. Your unit and your DMX controller require a standard 3-pin XLR connector for data input/output, see image below.



Further DMX cables can be purchased from all good sound and lighting suppliers or Pro Light Concepts dealers.

Please quote:

CABL10 – 2m

CABL11 – 5m

CABL12 – 10m

Also remember that DMX cable must be daisy chained and cannot be split.

Notice:

Be sure to follow the diagrams below when making your own cables. Do not connect the cables shield conductor to the ground lug or allow the shield conductor to come in contact with the XLRs outer casing. Grounding the shield could cause a short circuit and erratic behaviour.

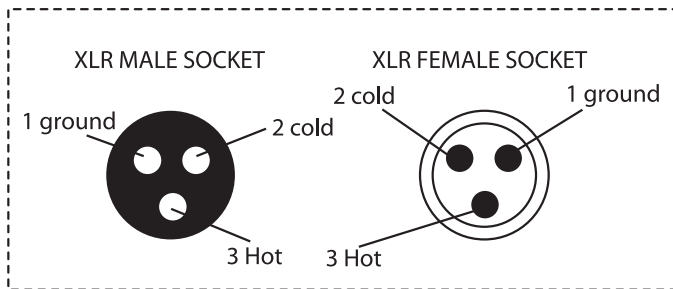
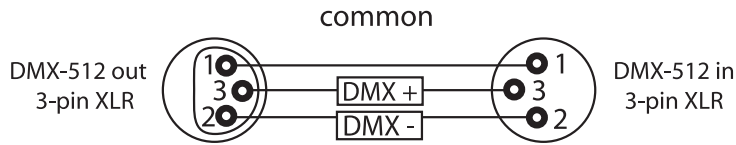

XLR Pin Configuration
Pin 1 = Ground
Pin 2 = Negative
Pin 3 = Postive

Special note:

Line termination:

When longer runs of cable are used, you may need to use a terminator on the last unit to avoid erratic behaviour.

Using a cable terminator will decrease the possibilities of erratic behaviour.

(3-pin - Order ref: CABL90, 5-pin - Order ref: CABL89)

Termination reduces signal transmission problems and interference. it is always advisable to connect a DMX terminal, (resistance 120 Ohm 1/4 W) between pin 2 (DMX-) and pin 3 (DMX+) of the last fixture.

5-pin XLR DMX connectors:

Some manufactures use 5-pin XLR connectors for data transmission in place of 3-pin. 5-pin XLR fixtures may be implemented in a 3-pin XLR DMX line. When inserting standard 5-pin XLR connectors in to a 3-pin line a cable adaptor must be used. The diagram below details the correct cable conversion.

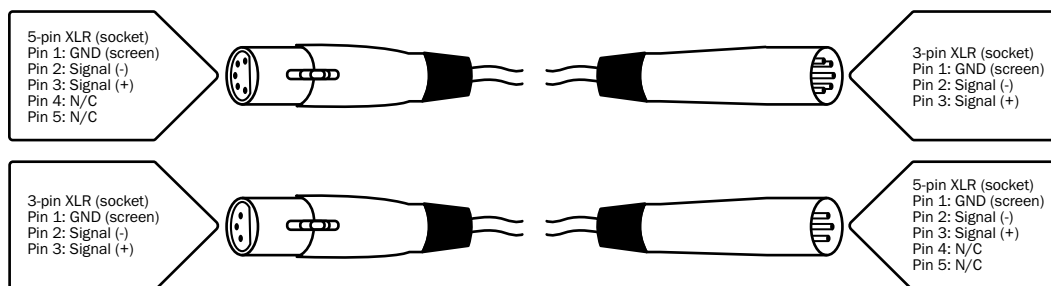



***Correct Disposal of this Product
(Waste Electrical & Electronic Equipment)***

**(Applicable in the European Union and other European countries
with separate collection systems)**

This marking shown on the product or its literature, indicates that it should not be disposed of with other household wastes at the end of its working life. To prevent possible harm to the environment or human health from uncontrolled waste disposal, please separate this from other types of wastes and recycle it responsibly to promote the sustainable reuse of material resources.

Household users should contact either the retailer where they purchased this product, or their local government office, for details of where and how they can take this item for environmentally safe recycling.

Business users should contact their supplier and check the terms and conditions of the purchase contract. This product should not be mixed with other commercial wastes for disposal.







