

EQUIN  X

TRINITY BEAM

Order code: EQLA42



User manual

WARNING

**FOR YOUR OWN SAFETY, PLEASE READ THIS USER MANUAL CAREFULLY
BEFORE YOUR INITIAL START-UP!**

**CAUTION!**

**Keep this equipment away from rain,
moisture and liquids.**

**SAFETY INSTRUCTIONS**

Every person involved with the installation, operation & maintenance of this equipment should:

- Be competent
- Follow the instructions of this manual



**CAUTION! TAKE CARE USING THIS EQUIPMENT!
HIGH VOLTAGE-RISK OF ELECTRIC SHOCK!!**



Before your initial start-up, please make sure that there is no damage caused during transportation. Should there be any, consult your dealer and do not use the equipment.

To maintain the equipment in good working condition and to ensure safe operation, it is necessary for the user to follow the safety instructions and warning notes written in this manual.

Please note that damages caused by user modifications to this equipment are not subject to warranty.

IMPORTANT:

The manufacturer will not accept liability for any resulting damages caused by the non-observance of this manual or any unauthorised modification to the equipment.

- Never let the power-cable come into contact with other cables. Handle the power-cable and all mains voltage connections with particular caution!
- Never remove warning or informative labels from the equipment.
- Do not open the equipment and do not modify the equipment.
- Do not connect this equipment to a dimmer-pack.
- Do not switch the equipment on and off in short intervals, as this will reduce the system's life.
- Only use the equipment indoors.
- Do not expose to flammable sources, liquids or gases.
- Always disconnect the power from the mains when equipment is not in use or before cleaning! Only handle the power-cable by the plug. Never pull out the plug by pulling the power-cable.
- Make sure that the available voltage is between 220v/240v.
- Make sure that the power-cable is never crimped or damaged. Check the equipment and the power-cable periodically.
- If the equipment is dropped or damaged, disconnect the mains power supply immediately. Have a qualified engineer inspect the equipment before operating again.
- If the equipment has been exposed to drastic temperature fluctuation (e.g. after transportation), do not switch it on immediately. The arising condensation might damage the equipment. Leave the equipment switched off until it has reached room temperature.
- If your product fails to function correctly, discontinue use immediately. Pack the unit securely (preferably in the original packing material), and return it to your Prolight dealer for service.
- Only use fuses of same type and rating.
- Repairs, servicing and power connection must only be carried out by a qualified technician. **THIS UNIT CONTAINS NO USER SERVICEABLE PARTS.**
- **WARRANTY;** One year from date of purchase.

OPERATING DETERMINATIONS

If this equipment is operated in any other way, than those described in this manual, the product may suffer damage and the warranty becomes void.

Incorrect operation may lead to danger e.g.: short-circuit, burns, electric shocks, lamp failure etc.

Do not endanger your own safety and the safety of others!
Incorrect installation or use can cause serious damage to people and property.

You should find inside the Laser carton the following items:

- 1, Trinity Beam Laser 2, Power cable 3, User manual 4, Safety Keys

Technical Specifications:

DMX channels: 2

Laser diodes: 1 x 80mW Green (532nm) DPSS laser, 1 x 400mW Blue (450nm) DPSS laser
1 x 300mW Red (650nm) DPSS laser

Operating modes: 1, Sound Active
2, Auto Run
3, DMX
4, Master/slave

Power consumption: 220W

Power supply: 240V - 50Hz

Dimensions: 350 x 392 x 110mm

Weight: 4.6Kgs

Fuse: 2A

Features:

The Trinity Beam Laser features 7 DMX channels and many laser patterns that are ideal with or without fog.

Back view:

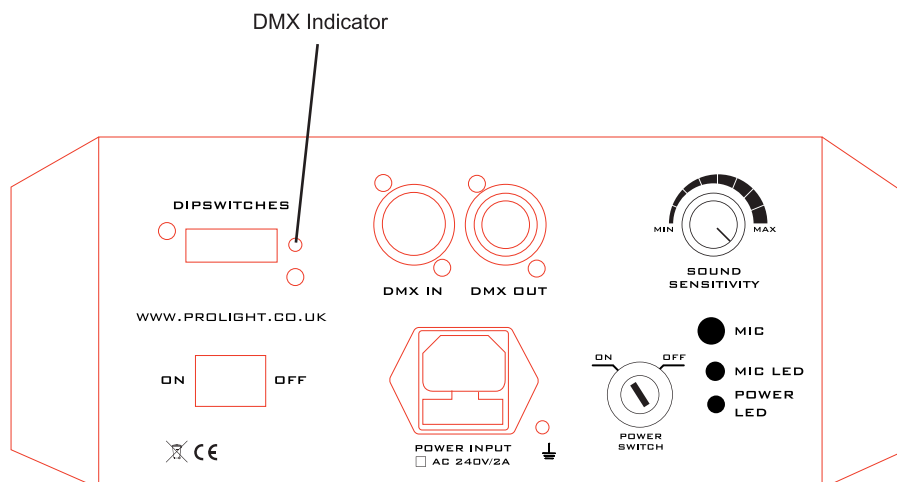

Hanging bracket positioning:

When you first open the Trinity Beam carton, you will notice that the hanging bracket is placed on back of the unit, this is for installation set up (fig 1). For mobile rigging use, please attach the extra brackets (included in the carton) to the additional screw holes on the side of the fixture (fig 2).

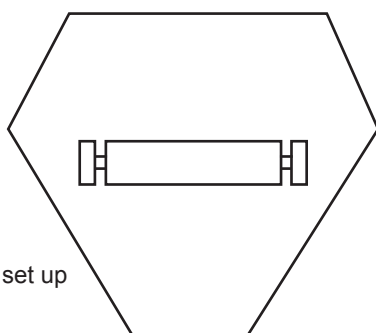

Fig 1
Installation set up

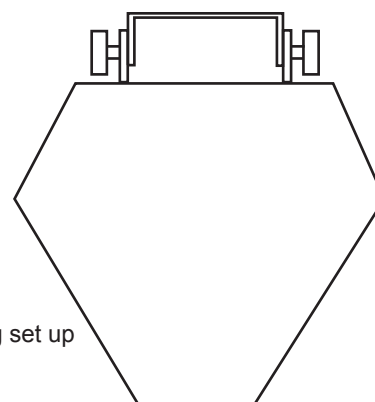

Fig 2
Mobile rigging set up

Operation modes:

The Trinity Beam has 4 modes of operation as follows:

1, Sound active mode

To select sound active mode set dip switch 10 to **ON** and all others to **OFF**. You can now use the sensitivity control on the back panel to set the required sound level.

2, Auto run mode

To select auto pattern mode, set dip switch 9 and 10 to the **ON** position and all others to **OFF**. The Trinity Beam will now cycle through all it's internal patterns.

3, DMX mode

To select DMX mode, set dip switch 10 to **OFF**. You can now set the required DMX address using dip switches 1 to 9. Please refer to the chart below for DMX functions.

The DMX address starts at 1.

4, Master/slave mode

To set the unit/s in slave mode, set dip switch 3 to the **ON** position and all others to **OFF**. The Trinity Beam laser/s will now run in sequence with the master unit.

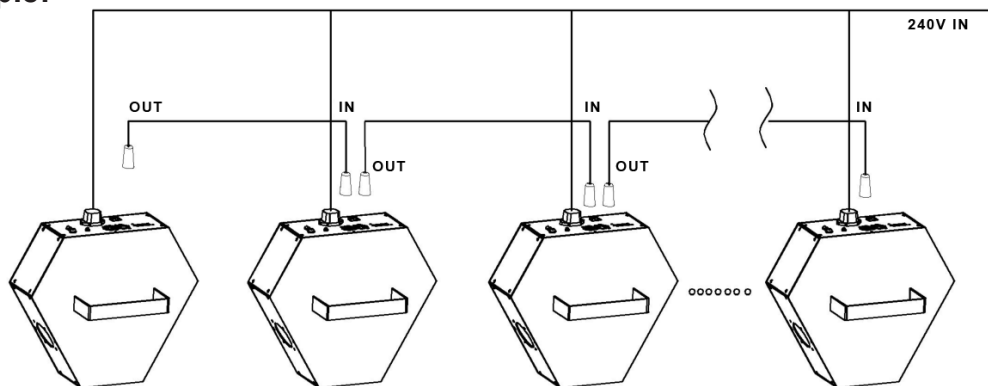
Example:**DMX function chart:**

| Channel | DMX Address | Function |
|---------|-------------|---|
| CH.1 | 0-70 | Blackout |
| | 71-140 | Sound active |
| | 141-210 | Auto run |
| | 211-255 | DMX manual mode |
| CH.2 | 0-255 | 28 Pattern selector (CH.1, DMX manual mode) |

DMX Control Mode

Operating in a DMX control mode environment gives the user the greatest flexibility when it comes to customising or creating a show. In this mode you will be able to control each individual trait of the fixture and each fixture independently.

Setting the DMX address

The DMX mode enables the use of a universal DMX controller. Each fixture requires a “start address” from 1- 511. A fixture requiring one or more channels for control begins to read the data on the channel indicated by the start address. For example, a fixture that occupies or uses 7 channels of DMX and was addressed to start on DMX channel 100, would read data from channels: 100,101,102,103,104,105 and 106. Choose a start address so that the channels used do not overlap. E.g. the next unit in the chain starts at 107.

Set the start address using the group of dip switches located usually on the back of the fixture. Each dip switch has an associated value. Adding the value of each switch in the ON position will provide the start address. Determining which switches to toggle ON given a specific start address can be accomplished in the following manner. By subtracting the largest switch value possible from the selected start address until zero is achieved.

| <p>EXAMPLE STARTING ADDRESS</p> <hr/> <p>Address 10</p> <p>Pin NO: 4 = 8 Pin NO: 2 = 2 Total = 10</p> | | | | | | | | | | | | | | | | | | | | | | | |
|---|---|------------|-------------|---|---|---|---|---|---|---|---|---|----|---|----|---|----|---|-----|---|-----|----|--|
| <p>Address 24</p> <p>Pin NO: 5 = 16 Pin NO: 4 = 8 Total = 24</p> | | | | | | | | | | | | | | | | | | | | | | | |
| <p>DMX address using simple maths</p> | <p>233 - (128 = 105, Turn on dip No: 8 105 - (64) = 41, Turn on dip No: 7 41 - (32) = 9, Turn on dip No: 6 9 - (8) = 1, Turn on dip No: 4 1 - (1) = 0, Turn on dip No: 1</p> <p>You will most likely use the first available number which maybe Number 1. This number was selected for example purposes</p> <table border="1" style="margin-left: auto; margin-right: auto;"> <thead> <tr> <th>DIP SWITCH</th> <th>(DMX VALUE)</th> </tr> </thead> <tbody> <tr><td>1</td><td>1</td></tr> <tr><td>2</td><td>2</td></tr> <tr><td>3</td><td>4</td></tr> <tr><td>4</td><td>8</td></tr> <tr><td>5</td><td>16</td></tr> <tr><td>6</td><td>32</td></tr> <tr><td>7</td><td>64</td></tr> <tr><td>8</td><td>128</td></tr> <tr><td>9</td><td>256</td></tr> <tr><td>10</td><td></td></tr> </tbody> </table> | DIP SWITCH | (DMX VALUE) | 1 | 1 | 2 | 2 | 3 | 4 | 4 | 8 | 5 | 16 | 6 | 32 | 7 | 64 | 8 | 128 | 9 | 256 | 10 | |
| DIP SWITCH | (DMX VALUE) | | | | | | | | | | | | | | | | | | | | | | |
| 1 | 1 | | | | | | | | | | | | | | | | | | | | | | |
| 2 | 2 | | | | | | | | | | | | | | | | | | | | | | |
| 3 | 4 | | | | | | | | | | | | | | | | | | | | | | |
| 4 | 8 | | | | | | | | | | | | | | | | | | | | | | |
| 5 | 16 | | | | | | | | | | | | | | | | | | | | | | |
| 6 | 32 | | | | | | | | | | | | | | | | | | | | | | |
| 7 | 64 | | | | | | | | | | | | | | | | | | | | | | |
| 8 | 128 | | | | | | | | | | | | | | | | | | | | | | |
| 9 | 256 | | | | | | | | | | | | | | | | | | | | | | |
| 10 | | | | | | | | | | | | | | | | | | | | | | | |

DMX-512:

- DMX (Digital Multiplex) is a universal protocol used as a form of communication between intelligent fixtures and controllers. A DMX controller sends DMX data instructions from the controller to the fixture. DMX data is sent as serial data that travels from fixture to fixture via the DATA “IN” and DATA “OUT” XLR terminals located on all DMX fixtures (most controllers only have a data “out” terminal).

DMX Linking:

- DMX is a language allowing all makes and models of different manufactures to be linked together and operate from a single controller, as long as all fixtures and the controller are DMX compliant. To ensure proper DMX data transmission, when using several DMX fixtures try to use the shortest cable path possible. The order in which fixtures are connected in a DMX line does not influence the DMX addressing. For example; a fixture assigned to a DMX address of 1 may be placed anywhere in a DMX line, at the beginning, at the end, or anywhere in the middle. When a fixture is assigned a DMX address of 1, the DMX controller knows to send DATA assigned to address 1 to that unit, no matter where it is located in the DMX chain.

DATA Cable (DMX cable) requirements (for DMX operation):

- The Equinox Trinity Beam laser can be controlled via DMX-512 protocol. The DMX address is set on the back of the unit. Your unit and your DMX controller require a standard 3-pin XLR connector for data input/output (figure 1).

Figure 1

Further DMX cables can be purchased from all good sound and lighting suppliers or Prolight dealers.

Please quote:

CABL10 – 2M

CABL11 – 5M

CABL12 – 10M

Also remember that DMX cable must be daisy chained and cannot be split.

Notice:

- Be sure to follow figures 2 & 3 when making your own cables. Do not connect the cable's shield conductor to the ground lug or allow the shield conductor to come in contact with the XLR's outer casing. Grounding the shield could cause a short circuit and erratic behaviour.

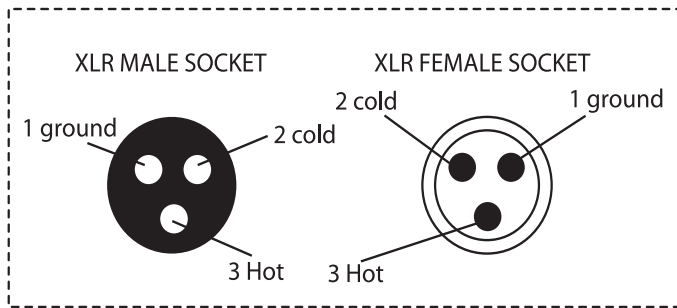
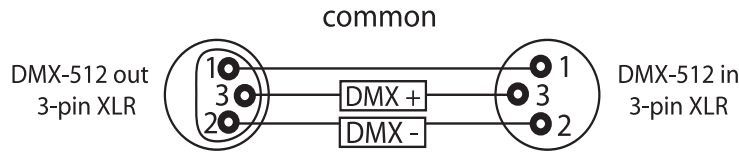

FIGURE 3

| XLR Pin Configuration |
|-----------------------|
| Pin 1 = Ground |
| Pin 2 = Negative |
| Pin 3 = Postive |

FIGURE 2

Special Note: Line termination:

- When longer runs of cable are used, you may need to use a terminator on the last unit to avoid erratic behaviour.

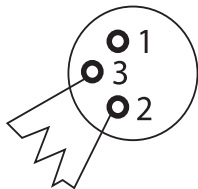

Termination reduces signal transmission problems and interference. it is always advisable to connect a DMX terminal, (resistance 120 Ohm 1/4 W) between pin 2 (DMX-) and pin 3 (DMX+) of the last fixture.

Using a cable terminator (part number CABL90) will decrease the possibilities of erratic behaviour.

5-Pin XLR DMX Connectors:

- Some manufactures use 5-pin XLR connectors for data transmission in place of 3-pin. 5-Pin XLR fixtures may be implemented in a 3-pin XLR DMX line. When inserting standard 5-pin XLR connectors in to a 3-pin line a cable adaptor must be used. The Chart below details the correct cable conversion.

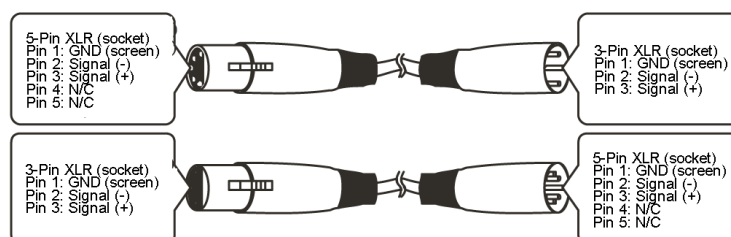

DMX Dip Switch Quick Reference Chart

Dip Switch Position

| DMX DIP SWITCH SET 0=OFF 1=ON | | | | | #9 | 0 | 0 | 0 | 0 | 0 | 0 | 0 | 0 | 1 | 1 | 1 | 1 | 1 | 1 | 1 | 1 | | |
|-------------------------------------|----|----|----|----|----|----|----|-----|-----|-----|-----|-----|-----|-----|-----|-----|-----|-----|-----|-----|---|---|---|
| | | | | | #8 | 0 | 0 | 0 | 0 | 1 | 1 | 1 | 1 | 0 | 0 | 0 | 0 | 1 | 1 | 1 | 1 | 1 | 1 |
| | | | | | #7 | 0 | 0 | 1 | 1 | 0 | 0 | 1 | 1 | 0 | 0 | 1 | 1 | 0 | 0 | 1 | 1 | 1 | 1 |
| | | | | | #6 | 0 | 1 | 0 | 1 | 0 | 1 | 0 | 1 | 0 | 1 | 0 | 1 | 0 | 1 | 0 | 1 | 0 | 1 |
| #1 | #2 | #3 | #4 | #5 | | | | | | | | | | | | | | | | | | | |
| 0 | 0 | 0 | 0 | 0 | | 32 | 64 | 96 | 128 | 160 | 192 | 224 | 256 | 288 | 320 | 352 | 384 | 416 | 448 | 480 | | | |
| 1 | 0 | 0 | 0 | 0 | 1 | 33 | 65 | 97 | 129 | 161 | 193 | 225 | 257 | 289 | 321 | 353 | 385 | 417 | 449 | 481 | | | |
| 0 | 1 | 0 | 0 | 0 | 2 | 34 | 66 | 98 | 130 | 162 | 194 | 226 | 258 | 290 | 322 | 354 | 386 | 418 | 450 | 482 | | | |
| 1 | 1 | 0 | 0 | 0 | 3 | 35 | 67 | 99 | 131 | 163 | 195 | 227 | 259 | 291 | 323 | 355 | 387 | 419 | 451 | 483 | | | |
| 0 | 0 | 1 | 0 | 0 | 4 | 36 | 68 | 100 | 132 | 164 | 196 | 228 | 260 | 292 | 324 | 356 | 388 | 420 | 452 | 484 | | | |
| 1 | 0 | 1 | 0 | 0 | 5 | 37 | 69 | 101 | 133 | 165 | 197 | 229 | 261 | 293 | 325 | 357 | 389 | 421 | 453 | 485 | | | |
| 0 | 1 | 1 | 0 | 0 | 6 | 38 | 70 | 102 | 134 | 166 | 198 | 230 | 262 | 294 | 326 | 358 | 390 | 422 | 454 | 486 | | | |
| 1 | 1 | 1 | 0 | 0 | 7 | 39 | 71 | 103 | 135 | 167 | 199 | 231 | 263 | 295 | 327 | 359 | 391 | 423 | 455 | 487 | | | |
| 0 | 0 | 0 | 1 | 0 | 8 | 40 | 72 | 104 | 136 | 168 | 200 | 232 | 264 | 296 | 328 | 360 | 392 | 424 | 456 | 488 | | | |
| 1 | 0 | 0 | 1 | 0 | 9 | 41 | 73 | 105 | 137 | 169 | 201 | 233 | 265 | 297 | 329 | 361 | 393 | 425 | 457 | 489 | | | |
| 0 | 1 | 0 | 1 | 0 | 10 | 42 | 74 | 106 | 138 | 170 | 202 | 234 | 266 | 298 | 330 | 362 | 394 | 426 | 458 | 490 | | | |
| 1 | 1 | 0 | 1 | 0 | 11 | 43 | 75 | 107 | 139 | 171 | 203 | 235 | 267 | 299 | 331 | 363 | 395 | 427 | 459 | 491 | | | |
| 0 | 0 | 1 | 1 | 0 | 12 | 44 | 76 | 108 | 140 | 172 | 204 | 236 | 268 | 300 | 332 | 364 | 396 | 428 | 460 | 492 | | | |
| 1 | 0 | 1 | 1 | 0 | 13 | 45 | 77 | 109 | 141 | 173 | 205 | 237 | 269 | 301 | 333 | 365 | 397 | 429 | 461 | 493 | | | |
| 0 | 1 | 1 | 1 | 0 | 14 | 46 | 78 | 110 | 142 | 174 | 206 | 238 | 270 | 302 | 334 | 366 | 398 | 430 | 462 | 494 | | | |
| 1 | 1 | 1 | 1 | 0 | 15 | 47 | 79 | 111 | 143 | 175 | 207 | 239 | 271 | 303 | 335 | 367 | 399 | 431 | 463 | 495 | | | |
| 0 | 0 | 0 | 0 | 1 | 16 | 48 | 80 | 112 | 144 | 176 | 208 | 240 | 272 | 304 | 336 | 368 | 400 | 432 | 464 | 496 | | | |
| 1 | 0 | 0 | 0 | 1 | 17 | 49 | 81 | 113 | 145 | 177 | 209 | 241 | 273 | 305 | 337 | 369 | 401 | 433 | 465 | 497 | | | |
| 0 | 1 | 0 | 0 | 1 | 18 | 50 | 82 | 114 | 146 | 178 | 210 | 242 | 274 | 306 | 338 | 370 | 402 | 434 | 466 | 498 | | | |
| 1 | 1 | 0 | 0 | 1 | 19 | 51 | 83 | 115 | 147 | 179 | 211 | 243 | 275 | 307 | 339 | 371 | 403 | 435 | 467 | 499 | | | |
| 0 | 0 | 1 | 0 | 1 | 20 | 52 | 84 | 116 | 148 | 180 | 212 | 244 | 276 | 308 | 340 | 372 | 404 | 436 | 468 | 500 | | | |
| 1 | 0 | 1 | 0 | 1 | 21 | 53 | 85 | 117 | 149 | 181 | 213 | 245 | 277 | 309 | 341 | 373 | 405 | 437 | 469 | 501 | | | |
| 0 | 1 | 1 | 0 | 1 | 22 | 54 | 86 | 118 | 150 | 182 | 214 | 246 | 278 | 310 | 342 | 374 | 406 | 438 | 470 | 502 | | | |
| 1 | 1 | 1 | 0 | 1 | 23 | 55 | 87 | 119 | 151 | 183 | 215 | 247 | 279 | 311 | 343 | 375 | 407 | 439 | 471 | 503 | | | |
| 0 | 0 | 0 | 1 | 1 | 24 | 56 | 88 | 120 | 152 | 184 | 216 | 248 | 280 | 312 | 344 | 376 | 408 | 440 | 472 | 504 | | | |
| 1 | 0 | 0 | 1 | 1 | 25 | 57 | 89 | 121 | 153 | 185 | 217 | 249 | 281 | 313 | 345 | 377 | 409 | 441 | 473 | 505 | | | |
| 0 | 1 | 0 | 1 | 1 | 26 | 58 | 90 | 122 | 154 | 186 | 218 | 250 | 282 | 314 | 346 | 378 | 410 | 442 | 474 | 506 | | | |
| 1 | 1 | 0 | 1 | 1 | 27 | 59 | 91 | 123 | 155 | 187 | 219 | 251 | 283 | 315 | 347 | 379 | 411 | 443 | 475 | 507 | | | |
| 0 | 0 | 1 | 1 | 1 | 28 | 60 | 92 | 124 | 156 | 188 | 220 | 252 | 284 | 316 | 348 | 380 | 412 | 444 | 476 | 508 | | | |
| 1 | 0 | 1 | 1 | 1 | 29 | 61 | 93 | 125 | 157 | 189 | 221 | 253 | 285 | 317 | 349 | 381 | 413 | 445 | 477 | 509 | | | |
| 0 | 1 | 1 | 1 | 1 | 30 | 62 | 94 | 126 | 158 | 190 | 222 | 254 | 286 | 318 | 350 | 382 | 414 | 446 | 478 | 510 | | | |
| 1 | 1 | 1 | 1 | 1 | 31 | 63 | 95 | 127 | 159 | 191 | 223 | 255 | 287 | 319 | 351 | 383 | 415 | 447 | 479 | 511 | | | |

Dip Switch position

DMX Address

Class 3B Laser Lighting Effect User Safety Guide ProLight Concepts Limited

Important Warnings

Class 3B Lasers have the potential to harm eyesight if viewed directly in the face, and in many instances this may be the case, even if viewed over longer distances of several tens of metres. Therefore before using the laser product you should familiarise yourself with its operation, and also the safety aspects that need to be considered.

Laser lighting effects are quite safe to watch if installed and used correctly, and being aware of a few basic factors will help you to achieve this. This guide has been prepared to help provide a basic backgrounder to the key safety aspects, and is based on current UK health and safety guidance on the use of lasers for public displays.

Installation and Operation Notes

1. The laser should only be installed and operated by those that are aware of how to operate laser, and what the various controls perform. The keyswitch provided on the laser should help to prevent use by unintended people.
2. The laser should be mounted in a suitable and secure position in the venue, so that once in position it is unlikely to be affected by unintended movement.
3. Prior to installation and operation of the laser, the paths of the beams and effects should be considered, particularly with respect to how they will touch the audience. If direct audience scanning is desired then the laser energy in the effects needs to be considered to decide if the effects are safe for direct viewing.

Introduction

Laser lighting products are used to create some of the most vivid and striking visual effects, and are often noted for how they seem to produce solid shapes that cut through the air, and pick up highly defined swirling smoke patterns. The light that is used to create these stunning effects is different from normal light and therefore several precautions need to be taken when using lasers to ensure that the lighting effects are safe and enjoyable to view. The optical power output from the kind of lasers used for lighting displays can be harmful if not properly setup or is misused. But when used following the recommended health and safety guidelines, laser lighting effects no more harmful than looking at any conventional lighting effect.

This guide has been put together to provide you with some background information about laser safety, and guidance on the recommended health and safety requirements for using lasers in public places. Although this guide covers the main points to consider when using laser effects, users are advised to familiarise themselves with other guidance, particularly that issued by the Health and Safety Executive, HS(G)95 The Radiation Safety Of Lasers Used For Display Purposes, which is freely downloadable from the HSE website. Attending one of the laser safety training courses, listed at the end of this guide, is also highly recommended.

What is a laser?

A laser is a device that produces a special kind of light that is different from normal light sources. Laser light sources differ from normal light sources in that they can produce very intense beams of light that can remain parallel over long distances. It is this high concentration of light that can sometimes make lasers harmful to look directly into.

What is a Class 3B Laser?

Any device that contains a laser has to be classified depending upon the amount of laser light that someone might be exposed to. During design and manufacture of the product, the manufacturer assigns the laser product to one of the various classes defined in the Laser Product Safety Standard (BS/EN 60825-1:2007). The classes range from the safest, which is Class 1, through to the most hazardous, which is Class 4.

For example, CD and DVD players contain lasers to read the disk, and because they are normally inaccessible to people, they are classified as a Class 1 laser product. Laser Pointers output more accessible power than CD/DVD players and are normally limited to being Class 2 devices. While most laser lighting effects products are Class 3B and Class 4 laser products. These two classes have the highest potential to cause harm because they emit the greatest light output. This is, of course, desirable and necessary for laser lighting effects!

A laser product that emits more than 5mW of light and less than 500mW is normally classified as a Class 3B laser product, meaning it carries a risk of harming eyesight if viewed directly.

Are Class 3B Laser Lighting Effects safe to view?

Yes, if used responsibly, and in accordance with the relevant guidance issued by the Health and Safety Executive.

In the simplest terms, generally keeping the beams and effects above the audience will not present a hazard to those viewing the show or effects. When you start to aim the laser effects down into the audience area is when it becomes harder to tell if the effects could cause harm. With a Class 3B laser lighting effect, the problem can arise if the beams or effects actually hit someone's face.

If in doubt, keep the effects above the audience.

What harm can a Class 3B Laser cause?

Class 3B laser devices can be harmful to eyesight if viewed directly. i.e. that is, the beam or effect strikes the face of a person. The actual injury that a Class 3B laser can cause depends upon a number of factors, including how long the laser beam enters the eye for, the intensity of light, and what part of the eye it actually gets focused onto. The most susceptible part of the eye to receive damage from a laser is the internal back wall of the eyeball, known as the retina. It is this part of the eye that receives the light signals that are sent to brain. All light entering the eye gets focused onto the retina.

Normal light sources such as traditional light bulbs and regular lighting effects are normally not harmful to view. Lasers differ in that they can get focused down to very small points on the retina that can literally burn holes on the back of the eye, which can lead damage to eyesight. This process can happen in less time than it takes for a person to blink. There are no pain receptors on the retina, so the person will be unaware of any damage taking place. Damage caused to the retina is permanent, and can vary from unnoticeable loss of vision, through to severe loss of sight, particularly if the damage occurs in the part of the retina that senses the central vision.

Are there any laws or licences relating to using Class 3B lasers?

There are no specific “laser licences” that anybody needs in order to own or operate a laser for lightshow use. However, there is specific guidance issued by the Health and Safety Executive in the form of a document called HS(G)95 The Radiation Safety of Lasers Used for Display Purposes. HS(G)95 outlines a number of detailed points to consider when using lasers for lightshow purposes.

Furthermore, since April 2010 new health and safety legislation was introduced in the UK that sets legal limits as to the amount of laser light a person may be exposed to in the workplace. Class 3B lasers have the ability to exceed the safety limits. The full title of the laser safety regulations is the Control of Artificial Optical Radiation at Work Regulations 2010, which also define the need for risk assessment of the exposure levels.

Most places of public entertainment operate under a Public Entertainments Licence, which is issued by the Local Authority. The entertainment licence requirements will normally need to have a specific provision covering the use of lasers at the venue, where it is expected that the laser installation, (whether temporary or permanent), is to operated in compliance with the HS(G)95 laser safety guidance as part of the venue’s Public Entertainment Licence conditions.

The use of lasers, as any other equipment used for shows, will also be covered by more general health and safety legislation, such as the Health & Safety at Work Act 1974, and the Management of Health and Safety at Work Regulations 1999, etc. These regulations, among other things, state that you must ensure the safety of people present at the event where the laser is used, and also that a suitable risk assessment regarding the use of laser must be carried out.

Class 3B Laser Product Features

Class 3B laser products are required to have several specific safety features as part of their design. These features are laid out in the British Standard on Laser Product Safety BS/EN 60825-1:2007 and are a requirement of the product meeting CE approvals.

The important ones are listed below:-

- 1) Laser Safety Warning Labels
- 2) Key switch
- 3) Emissions Indicator
- 4) Remote Interlock Connector

Summary of each features purpose

The Class 3B laser projector should contain three Laser Safety Warning Labels; the starburst symbol, aperture label, and the warning/classification label. The starburst is intended to show that the product is a laser product, using the starburst symbol in the warning triangle. The aperture label is located to indicate where the laser projector emits its beams. The warning/classification label states the class of the laser product, the maximum output power, and the wavelength(s) (colours) of the laser, along with a warning " Laser Radiation – Avoid Exposure To The Beam"

The Keyswitch is provided to help limit the use of the laser projector to those that have key access. Without the key inserted and in the on position, the laser will not emit an output. The idea behind laser products having key switches is that only those people that are aware of how to operate the laser safely should be given access to the keys.

The emissions indicator is intended to show when the laser is ready to produce a light output.

The Remote Interlock Connector will only allow the laser to function when the two pins are shorted together. For lightshow use it is recommended by HS(G)95 laser safety guidance laser effects can be overridden by a remote Emergency Stop switch. The remote interlock connector provides a convenient way for such a switch to be easily added to the laser system, to provide this control.

Audience Scanning

Audience Scanning is the term commonly used to describe when laser effects are being directly aimed at the viewing audience. This creates a very dramatic looking effect, as people can touch the light, and look down smoky tunnels. But because the laser light can touch or scan past people's faces, it also carries a risk that it could cause damage to people's eyesight, if they are overexposed to the laser light.

Maximum Permissible Exposure (MPE)

The amount of laser light that a person can be exposed to without it causing harm to eyesight is known as the Maximum Permissible Exposure (MPE) or Exposure Limit Value (ELV). These levels are defined in the British Laser Safety Standard BS/EN 60826-1:2007, and more recently in the Laser H&S regulations. When people are exposed to laser light which is above the MPE, it poses a risk of causing eye damage. This could be of concern when the laser effects are viewed directly in the face or there is a chance that they could be.

How do I know what the MPE is?

Knowing what the MPE and exposure level is for a given laser effect is quite a complex and involved process to establish. For it is dependant on a whole number of conditions and variables that need to be taken into account. The laser safety standard BS/EN 60825-1:2007 contains the data required to calculate the safe levels, but it is not straightforward to interpret. Laser Safety Calculation Software has been developed to help ease the task of establishing laser effects exposure.

Laser Safety Officer

The PD IEC/TR 60825-14:2004 Laser Safety Guidance recommends that all establishments that use, or businesses that work with Class 3B laser products, should appoint a Laser Safety Officer (LSO). The Laser Safety Officer should be aware of the safety issues when using lasers, and is responsible for overseeing how the laser is used. In smaller businesses, the LSO will probably also be the installer, operator, owner etc.

Diffraction vs Direct X-Y Scanning Lasers

Diffraction type lasers have become increasingly popular in recent years creating laser effects that split the beam into hundreds, if not thousands of less powerful beamlets. This type of effect is usually much safer to view directly than traditional scanned beam effects, for the simple reason that as the beam is split into smaller beams, the power in each beam is reduced. With x-y scanning systems, even though it may look as if the power is being reduced by the movement, the moment any beam crosses a person's face, the full power of the beam may briefly enter someone's eye. Caution should still be used with diffraction effects, in particular ensuring that the brighter central beams are kept above head height.

Separation Distances

Health and Safety guidance states that for supervised installations laser light above the Maximum Permissible Exposure (MPE) should not be accessible to members of the audience. It also recommends the area where the MPE may not be exceeded, extends from 3m above, and 2.5m laterally from any location in the venue where members of the public may gain access during the display. The following diagrams illustrate this.

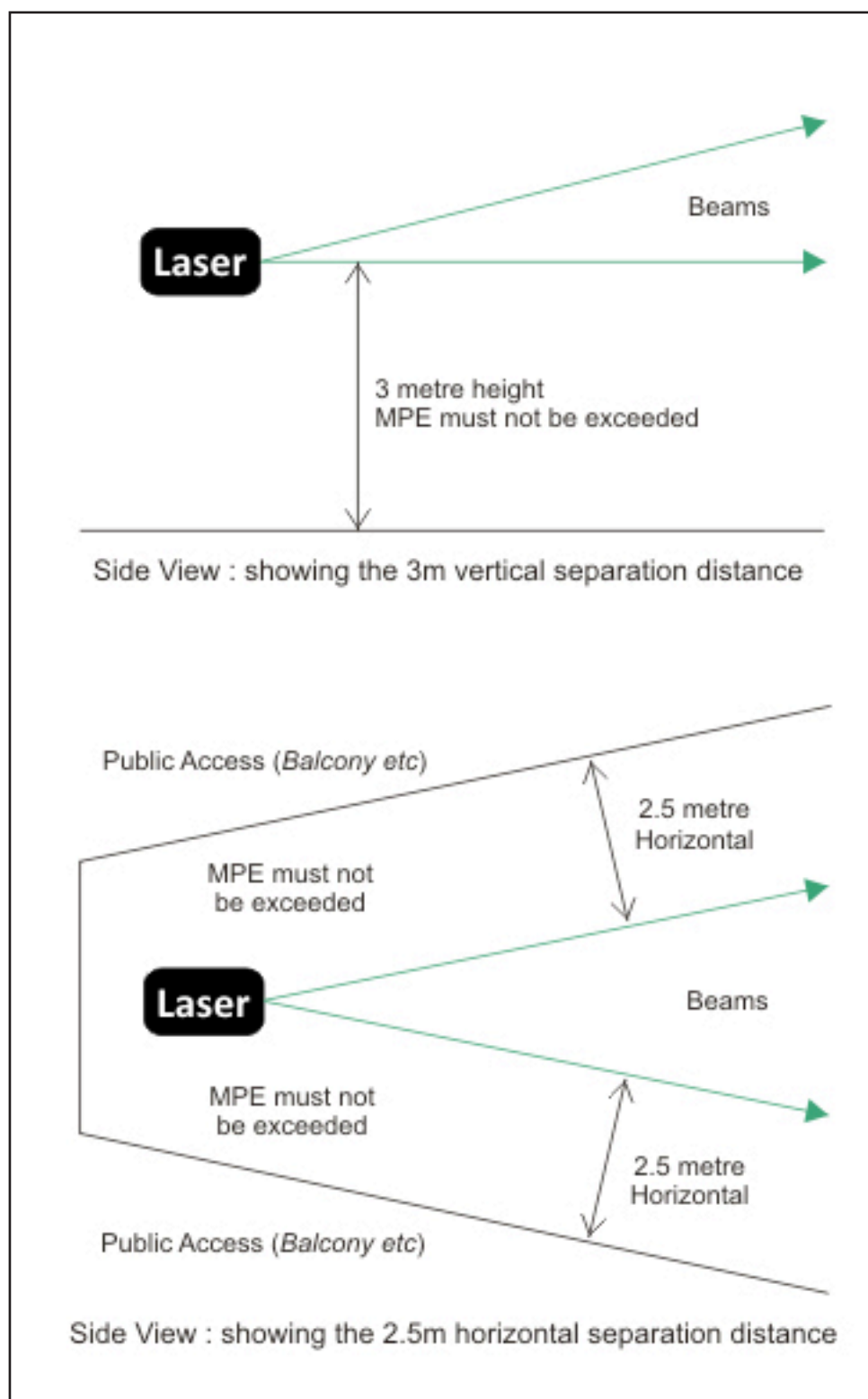
Diagrams showing Separation Distances

Note. The 3 metre height specified is not the height of the actual projector, but it refers to the height of the laser effect. Therefore having the laser projector positioned at 3m height and aimed directly down is not what the guidance is saying.

What types of effect are safe to scan directly at audiences?

Fast moving laser effects with evenly distributed scan patterns, such as circular tunnels are generally safer than effects such as finger beams, or effects with pronounced bright spots in them. Diffraction grating type effects are typically safer to point towards an audience, as long as the bright central spots are kept above head height. The important thing is to not guess if an effect is safe or not, and if in doubt keep it above head height. Being aware of the laser's hazard distance is useful to know.

Hazard Distances

All display lasers have a characteristic known as the hazard distance for direct viewing (NOHD). This is distance at which the hazard of viewing the laser directly no longer presents a hazard. i.e. at any point between the laser projector and the calculated hazard distance, it may be hazardous to view the laser directly. But viewing the laser directly from beyond the hazard distance is considered to be safe.

The worst case effect to look at directly is a static single beam, because all the light energy is concentrated into one point. The hazard distances for several different powers of typical Class 3B laser are shown in the table below, to give an idea of the distances involved.

| | | | | | | |
|--------------------|------|------|------|-------|-------|-------|
| Laser Output Power | 10mW | 30mW | 50mW | 100mW | 250mW | 450mW |
| Hazard Distance | 12m | 20m | 25m | 36m | 56m | 76m |

Table 1 Static Beam Hazard Distances.

Note - The values have been calculated assuming the characteristics of a typical laser lightshow device, which has a beam spread of 2mradians. Actual devices may differ in practice, so this table should only be used as a guide. Details of how to calculate laser hazard distances are detailed in the British Safety Standard, and many laser safety text books. It is also one of the topics usually covered in laser safety courses.

It can be seen that static laser beams can remain hazardous for considerable distances, which is why projecting such effects into peoples faces is not recommended.

Remember, projecting these beams overhead is fine, as long as they, or any reflections, are not hitting anybody.

When an effect such as a tunnel is projected, the continual scanning reduces the time the eye is directly exposed to the laser energy. These types of effect are less harmful to aim at the audience directly. The table below shows the hazard distances of a stationary circular tunnel, with a spread of 50 degrees, and a scan rate of 20Hz, to give an idea of how it is reduced.

| | | | | | | |
|--------------------|------|------|------|-------|-------|-------|
| Laser Output Power | 10mW | 30mW | 50mW | 100mW | 250mW | 450mW |
| Hazard Distance | 5m | 9m | 11m | 16m | 26m | 35m |

Table 2 Scanned Tunnel Hazard Distances.

Further Laser Safety Information and References

The Radiation Safety of Lasers used for Display Purposes HS(G)95
HSE's guidance on the safe use of lasers for light shows – Free download
<http://www.hse.gov.uk/pubns/books/hsg95.htm>

Control of Artificial Optical Radiation at Work Regulations 2010
New UK law specific to the use of lasers – Free download
http://www.opsi.gov.uk/si/si2010/pdf/uksi_20101140_en.pdf

A Non-Binding Guide to the Artificial Optical Radiation Directive
Pages 114-116 contain specific guidance on laser shows – Free download
<http://www.hse.gov.uk/radiation/nonionising/aor-guide.pdf>

BS/EN 60825-1:2007 Safety of Laser Products - Part 1
British Laser Product Safety Standard: Equipment Classification and Requirements
www.bsigroup.co.uk

PD IEC/TR 60825-3:2008 Guidance for Laser Displays and Shows
Issued by British Standards Institute
Website - www.bsigroup.co.uk

PD IEC/TR 60825-14:2004 Laser Safety User Guide
User Guide Issued by British Standards Institute
Website – www.bsigroup.co.uk

Health & Safety Executive
Website - www.hse.gov.uk

Laser Information and Safety Advice - Health Protection Agency
Website - www.hpa.org.uk

Laser Show Safety Information Website
Website - www.lasershowsafety.org

Laser Safety Calculation Software
Scanguard - LVR Limited
Website – www.lvrlimited.com

Laser Safety Training

LVR Limited – Laser Show Safety Training.
Website - www.lvrlimited.com

Health Protection Agency – General Laser Safety Training Courses
Website - www.hpa.org.uk

Copyright Notice – This document has been prepared for ProLight Concepts Limited by LVR Limited, who retains the copyright of this Laser Safety Guide. No part of this guide can be reproduced without the express written consent of LVR Limited.

Notes:

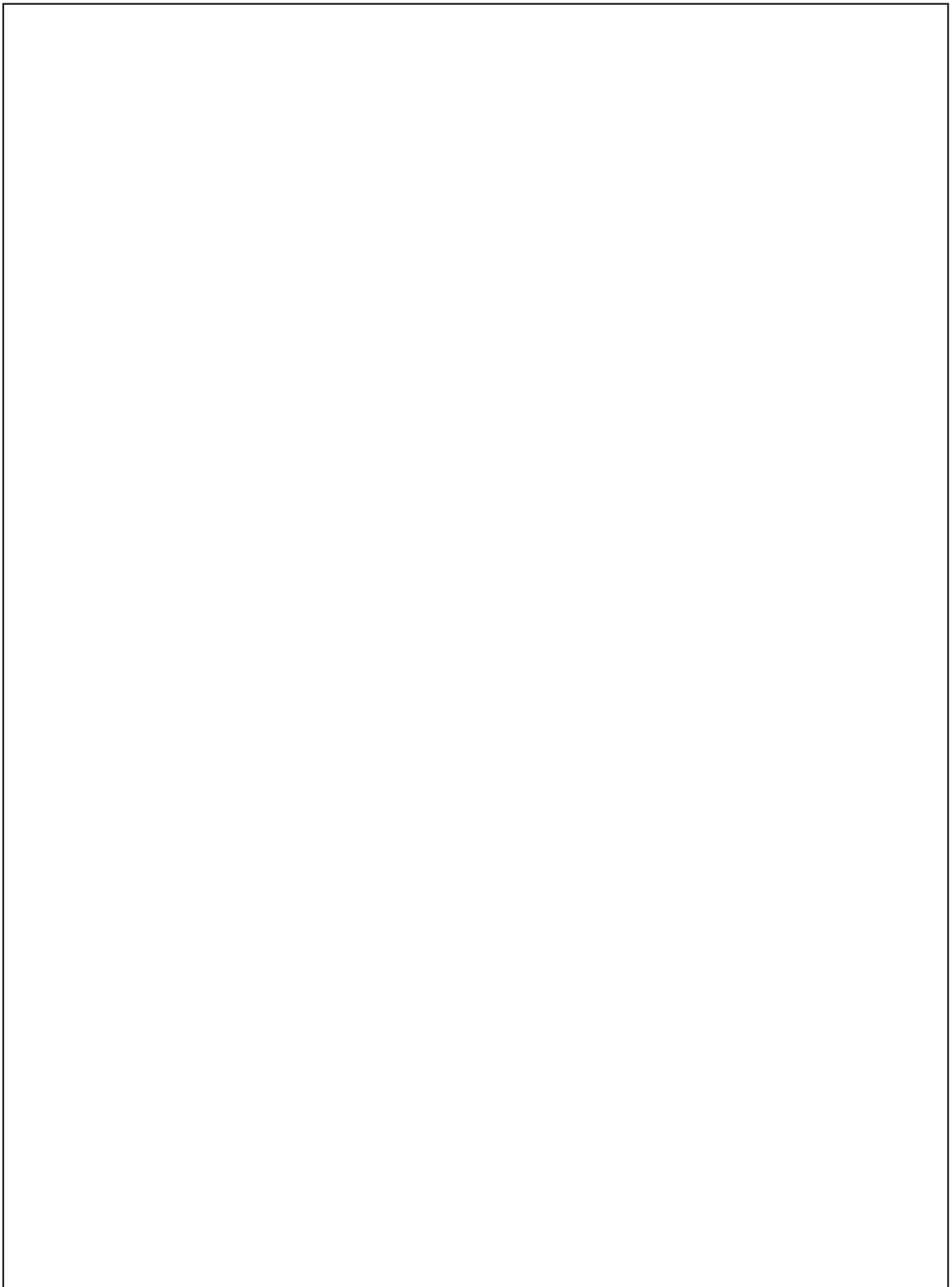
A large, empty rectangular box with a thin black border, occupying most of the page below the 'Notes:' header. It is intended for the user to write their notes.

EQUIN  X
www.prolight.co.uk