

iSolution

Your integrated Solution

iMove 350 Beam

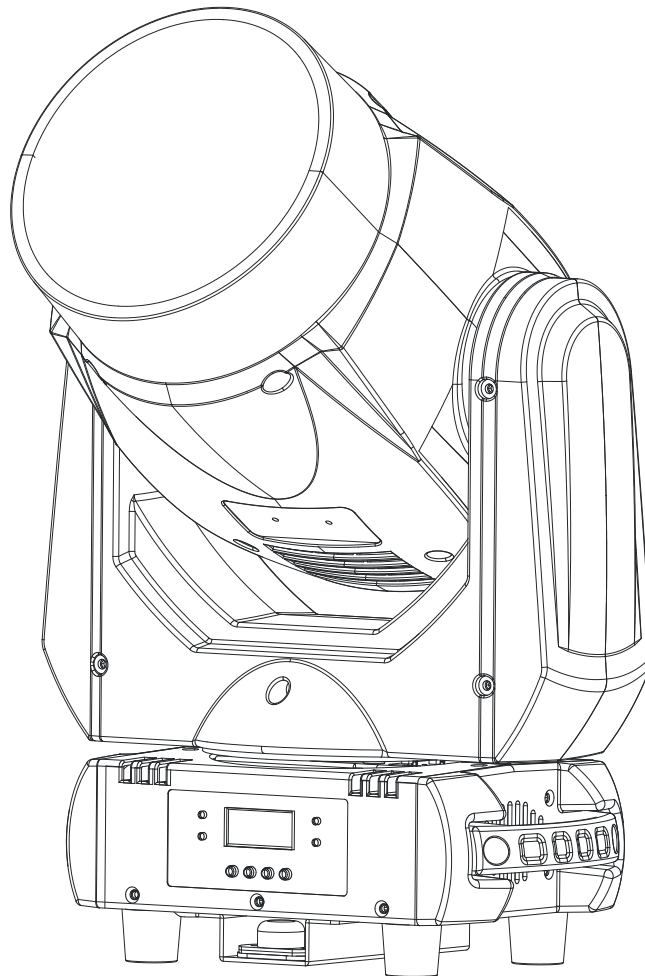

User Manual

Please read the instruction carefully before use

CONTENTS

1. Safety Instruction	2
2. Technical Specifications.....	3
3. How To Set The Unit.....	4
3.1 Control Panel	4
3.2 Main Function	5
3.3 Home Position Adjustment	12
4. How to Control the Unit.....	13
4.1 Master/Slave Built In Pre-program Function.....	14
4.2 Easy CA-8 Controller.....	14
4.3 DMX Controller.....	15
5. DMX512 Configuration.....	16
6. DMX Connection	18
7. Troubleshooting	19
8. Fixture Cleaning.....	20

1. Safety Instruction



WARNING

Please read the instruction carefully which includes important information about the installation, usage and maintenance.

Please keep this User Guide for future consultation. If you sell the unit to another user, be sure that they also receive this instruction booklet.

- Unpack and check carefully there is no transportation damage before using the unit.
- Before operating, ensure that the voltage and frequency of power supply match the power requirements of the unit.
- It's important to ground the yellow/green conductor to earth in order to avoid electric shock.
- The unit is for indoor use only. Use only in a dry location.
- The unit must be installed in a location with adequate ventilation, at least 50cm from adjacent surfaces. Be sure that no ventilation slots are blocked.
- Disconnect main power before replacement or servicing.
- Make sure there are no flammable materials close to the unit while operating as it is fire hazard.
- Use safety cables when installing this unit. DO NOT handle the unit by taking its head only, but always carry by its base.
- Maximum ambient temperature is T_a : 40 degrees C. DO NOT operate it where the temperature is higher than this.
- Unit surface temperature may reach up to 75 degrees C. DO NOT touch the housing with bare-hands during its operation. Turn off the power and allow 15 minutes for the unit to cool down before replacing or serving.
- In the event of a serious operating problem, stop using the unit immediately. Never try to repair the unit by yourself. Repairs carried out by unskilled people can lead to damage or malfunction. Please contact the nearest authorized technical assistance center. Always use the same type spare parts.
- DO NOT touch any cables during operation as high voltage may cause electric shock.

Warning:

- To prevent or reduce the risk of electrical shock or fire, do not expose the unit to rain or

moisture.

- The housing and the lenses must be replaced if they are visibly damaged.

Installation:

The fixture should be mounted via its Omega Quick Release Clamp bracket. Always ensure that the unit is firmly fixed to avoid vibration and slipping while operating. Make sure that the structure to which you are attaching the unit is secure and is able to support a weight of 10 times of the fixtures weight. Always use a safety cable that can hold 12 times of the weight of the fixture when installing.

The equipment must be installed by professionals. It must be installed in a place where is out of the reach of people and no one can pass by or under it.

2. Technical Specifications

- ◆ DMX channel modes: 8/11CH
- ◆ 3 DMX control modes: DMX, Master/Slave Mode, Sound Active mode
- ◆ 1 Rotation Gobo Wheel
- ◆ 1 Color Wheel
- ◆ Option easy controller CA-8 for instant lighting shows

Specification:

- **Power Voltage:** AC 100~240V, 50/60Hz
- **Power Consumption:** 130W
- **Light Source:** 1 x 60W White LED
- **Power Cable Daisy Chains:** 8 Fixtures Max. (230V, 50Hz)
4 Fixtures Max. (120V, 60Hz)
- **Beam Angle:** 6°
- **Dimension:** 292 x 185 x 461mm
- **Weight:** 7.5Kgs

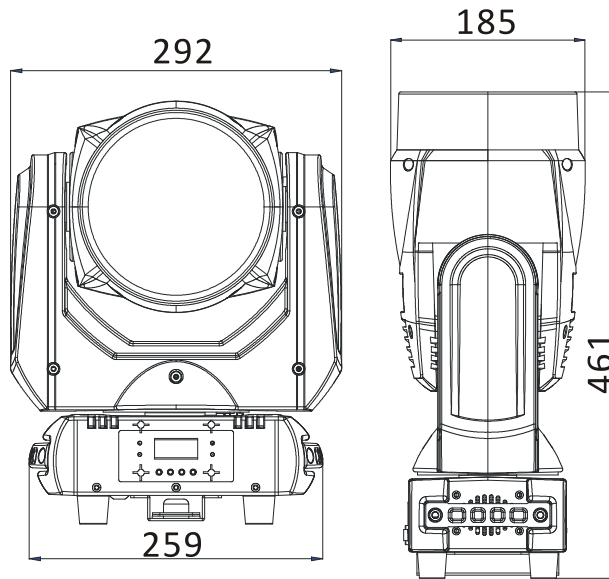

3. How To Set The Unit

3.1 Control Panel

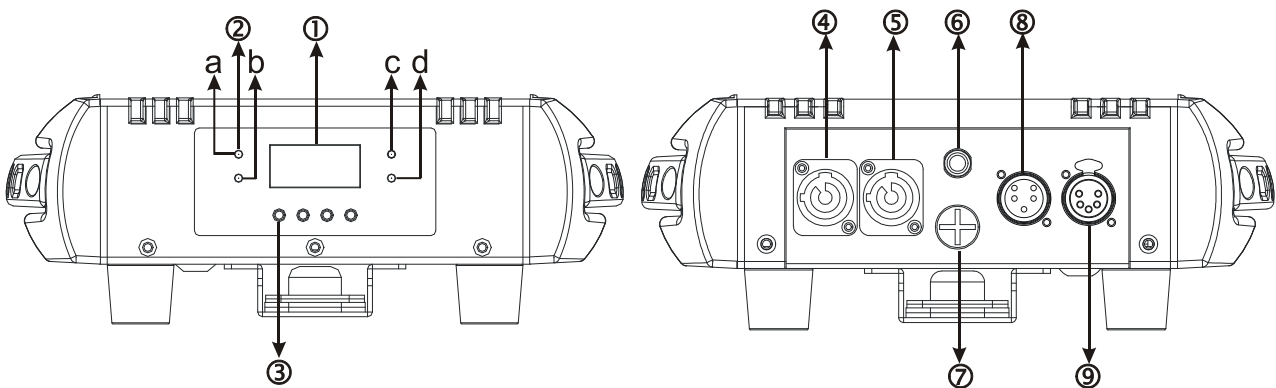

1. Function Display:

Shows the various menus and selected functions

2. LED:

a. DMX	On	DMX input present
b. MASTER	On	Master Mode
c. SLAVE	On	Slave Mode
d. SOUND	Flashing	Sound activation

3. Button:

MENU	To select the programming functions
▼ DOWN	To go backward in the selected functions

▲ UP	To go forward in the selected functions
ENTER	To confirm the selected functions

4. MAINS IN:

PowerCon connection from main power supply

5. MAINS OUT:

PowerCon loop connection for main power supply to the next unit

6. Only For Remote Control:

Connects to optional CA-8 to control the unit for Stand by, Function and Strobe/Blackout modes

7. Fuse (T 3.15A):

Protects the unit from over-voltage or short circuit

8. DMX IN:

DMX512 link, use 5-pin XLR cables to link the unit and the DMX controller

9. DMX OUT:

DMX512 link, use 5-pin XLR cables to link the next unit and output DMX signal

3.2 Main Function

To select any functions, press the **MENU** button until the required selection is showing on the display. Select the function by pressing the **ENTER** button and the display will blink. Use the **DOWN/UP** buttons to change the mode. Once the required mode has been selected, press the **ENTER** button to setup, to go back to the functions without any changes press the **MENU** button again. Press and hold the **MENU** button for about one second or wait for one minute to exit the menu mode.

The main functions are shown below:

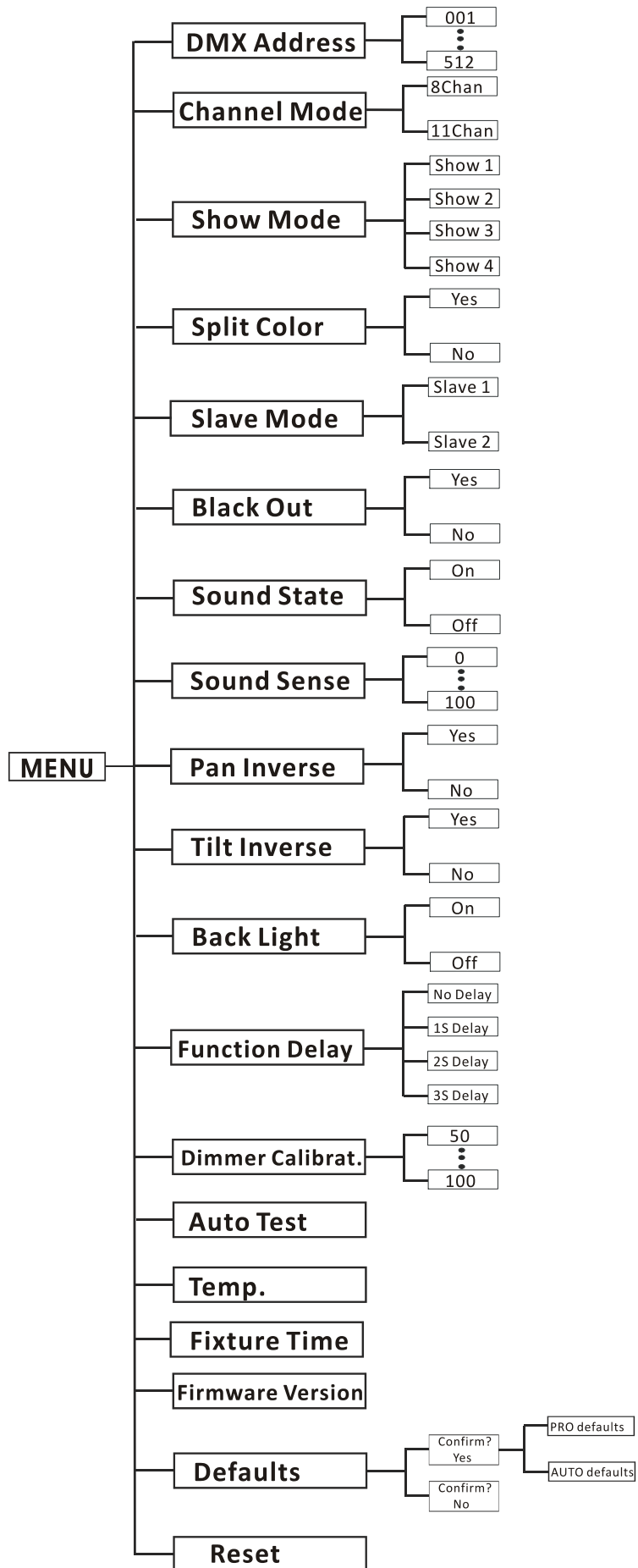

DMX Address

To select the **DMX Address**, press the **ENTER** button to show **DMX ADDRESS** on the display. Use the **DOWN/UP** buttons to adjust the address from **001** to **512**. Once the address has been selected, press the **ENTER** button to setup, to go back to the functions without any changes press the **MENU** button again. Press and hold the **MENU** button for about one second or wait for one minute to exit the menu mode.

Channel Mode

To select **Channel Mode**, press the **ENTER** button to show the **CHANNEL MODE** on the display. Use the **DOWN** and **UP** buttons to select the **8Chan** or **11Chan** mode. Once the mode has been selected, press the **ENTER** button to setup, to go back to the functions without any changes press the **MENU** button again. Press and hold the **MENU** button for about one second or wait for one minute to exit the menu mode.

Show Mode

To select the **Show Mode**, press the **ENTER** button to show **SHOW MODE** on the display. Use the **DOWN** and **UP** buttons to select the **Show 1**, **Show 2**, **Show 3** or **Show 4** Mode. Once the mode has been selected, press the **ENTER** button to setup, to go back to the functions without any changes press the **MENU** button again. Press and hold the **MENU** button for about one second or wait for one minute to exit the menu mode.

Split Color

To select the **Split Color**, press the **ENTER** button to show **SPLIT COLOR** on the display. Use the **DOWN** and **UP** buttons to select the **Yes** (Split color mode) or **No** (Normal). Once the mode has been selected, press the **ENTER** button to setup, to go back to the functions without any changes press the **MENU** button again. Press and hold the **MENU** button for about one second or wait for one minute to exit the menu mode.

Slave Mode

To select the **Slave Mode**, press the **ENTER** button to show **SLAVE MODE** on the display. Use the **DOWN** and **UP** buttons to select the **Slave 1** or **Slave 2** mode. Once the mode has been selected, press the **ENTER** button to setup, to go back to the functions without any changes press the **MENU** button again. Press and hold the **MENU** button for about one second or wait for one minute to exit the menu mode.

Black Out

To select **Black Out**, press the **ENTER** button to show **BLACK OUT** on the display. Use the **DOWN** and **UP** buttons to select the **Yes** (blackout) or **No** (normal) mode. Once the mode has been selected, press the **ENTER** button to setup, to go back to the functions without any changes press the **MENU** button again. Press and hold the **MENU** button for about one second or wait for one minute to exit the menu mode.

NOTE: If you set the fixture into black out mode it will no longer function in Sound/Master modes, it will only respond to DMX control

Sound State

To select the **Sound State**, press the **ENTER** button to show **SOUND STATE** on the display. Use the **DOWN** and **UP** buttons to select the **On** (Sound Mode On) or **Off** (Sound Mode Off). Once the mode has been selected, press the **ENTER** button to setup, to go back to the functions without any changes press the **MENU** button again. Press and hold the **MENU** button for about one second or wait for one minute to exit the menu mode.

Sound Sense (Sensitivity)

To select the **Sound Sense**, press the **ENTER** button to show **SOUND SENSE** on the display. Use the **DOWN** and **UP** buttons to adjust the sound sensitivity from **0** to **100**, press the **ENTER** button to setup, to go back to the functions without any changes press the **MENU** button again. Press and hold the **MENU** button for about one second or wait for one minute to exit the menu mode.

Pan Inverse

To select the **Pan Inverse**, press the **ENTER** button to show **PAN INVERSE** on the display. Use the **DOWN** and **UP** buttons to select the **Yes** (pan inversion) or **No** (normal) mode. Once the mode has been selected, press the **ENTER** button to setup, to go back to the functions without any changes press the **MENU** button again. Press and hold the **MENU** button for about one second or wait for one minute to exit the menu mode.

Tilt Inverse

To select the **Tilt Inverse**, press the **ENTER** button to show **TILT INVERSE** on the display. Use the **DOWN** and **UP** buttons to select the **Yes** (tilt inversion) or **No** (normal) mode. Once the mode has been selected, press the **ENTER** button to setup, to go back to the functions without any changes press the **MENU** button again. Press and hold the **MENU** button for about one second or wait for one minute to exit the menu mode.

Back Light

To select the **Back Light**, press the **ENTER** button to show **BACK LIGHT** on the display. Use the **DOWN** and **UP** buttons to select the **On** (display on) or **Off** (display off) mode. Once the mode has been selected, press the **ENTER** button to setup, to go back to the functions without any changes press the **MENU** button again. Press and hold the **MENU** button for about one second or wait for one minute to exit the menu mode.

Function Delay

To select the **Function Delay**, press the **ENTER** button to show **FUNCTION DELAY** on the display. Use the **DOWN** and **UP** buttons to select the **No Delay** or **1S Delay**, **2S Delay** or **3S Delay** (wait for a few seconds seconds before the functions for 8/11CH are activated/deactivated). Once selected, press the **ENTER** button to setup, to go back to the functions without any changes press the

MENU button again. Press and hold the **MENU** button for about one second or wait for one minute to exit the menu mode.

Dimmer Calibration

To select the **Dimmer Calibration.**, press the **ENTER** button to show the **DIMMER CALIBRAT.** on the display. Use the **DOWN** and **UP** buttons to adjust the dimmer from **50** to **100**, press the **ENTER** button to setup, to go back to the functions without any changes press the **MENU** button again. Hold and press the **MENU** button about one second or wait for one minute to exit the menu mode.

Auto Test

To select the **Auto Test**, press the **ENTER** button to show the **AUTO TEST** on the display and the unit will run a self-test. To go back to the functions press the **MENU** button again. Press and hold the **MENU** button for about one second or wait for one minute to exit the menu mode.

Temp

To select the **Temp**, press the **ENTER** button to show **TEMP.** on the display and the display will show the temperature of the unit. When the temperature is under 55 degrees C, the fixture works normally; when it's between 70 degrees C and 75 degrees C, the fixture will reduce the power output; when it reaches 75 degrees C or higher, the LED will switch OFF. To go back to the functions press the **MENU** button again. Press and hold the **MENU** button for about one second or wait for one minute to exit the menu mode.

Fixture Time

To select the **Fixture Time**, press the **ENTER** button to show **FIXTURE TIME** on the display and the display will show the number of working hours of the fixture. To go back to the functions press the **MENU** button again. Press and hold the **MENU** button for about one second or wait for one

minute to exit the menu mode.

Firmware Version

To select the **Firmware Version**, press the **ENTER** button to show **FIRMWARE VERSION** on the display and the display will show the version of software of the unit. To go back to the functions press the **MENU** button again. Press and hold the **MENU** button for about one second or wait for one minute to exit the menu mode.

Defaults

To select the **Defaults**, press the **ENTER** button to show **DEFAULTS** on the display. Use the **DOWN** and **UP** buttons to select **Confirm? Yes** or **Confirm? No**. Once **Confirm? Yes** has been selected, use the **DOWN** and **UP** button to select the **PRO defaults** or **AUTO defaults**.

PRO Defaults: For professional users, detailed as follows:

- ☞ **Channel Mode** → 11Chan
- ☞ **Split Colour Mode** → Yes
- ☞ **Slave Mode** → Slave 1
- ☞ **Black Out** → Yes
- ☞ **Sound State** → Off
- ☞ **Sound Sense** → 90
- ☞ **Pan Inverse** → No
- ☞ **Tilt Inverse** → No
- ☞ **Back Light** → Off
- ☞ **Function Delay** → 3S Delay

AUTO Defaults: Automatic mode, detailed as follows:

- ☞ **Channel Mode** → 8Chan
- ☞ **Split Colour Mode** → No
- ☞ **Slave Mode** → Slave 1
- ☞ **Black Out** → No
- ☞ **Sound State** → On
- ☞ **Sound Sense** → 90
- ☞ **Pan Inverse** → No
- ☞ **Tilt Inverse** → No
- ☞ **Back Light** → On
- ☞ **Function Delay** → 3S Delay

(**Notice:** Other settings are NOT changed when choosing Defaults Setting!)

Press the **ENTER** button and the corresponding functions will be set to the defaults setting, to go back to the functions without any changes press the **MENU** button again. Press and hold the **MENU** button for about one second or wait for one minute to exit the menu mode.

Reset

To select the **Reset**, press the **ENTER** button to show **RESET** on the display, and all channels of the unit will return to their standard position. To go back to the functions press the **MENU** button again. Press and hold the **MENU** button for about one second or wait for one minute to exit the menu mode.

3.3 Home Position Adjustment

Press the **MENU** button into menu mode, then press the **ENTER** button for about 3 seconds to enter **OFFSET** mode to adjust the home position. Select the required function with the **ENTER** button, and use **DOWN/UP** button to choose the submenu, press the **ENTER** button to store and automatically return to the last menu. Press the **MENU** button to exit.

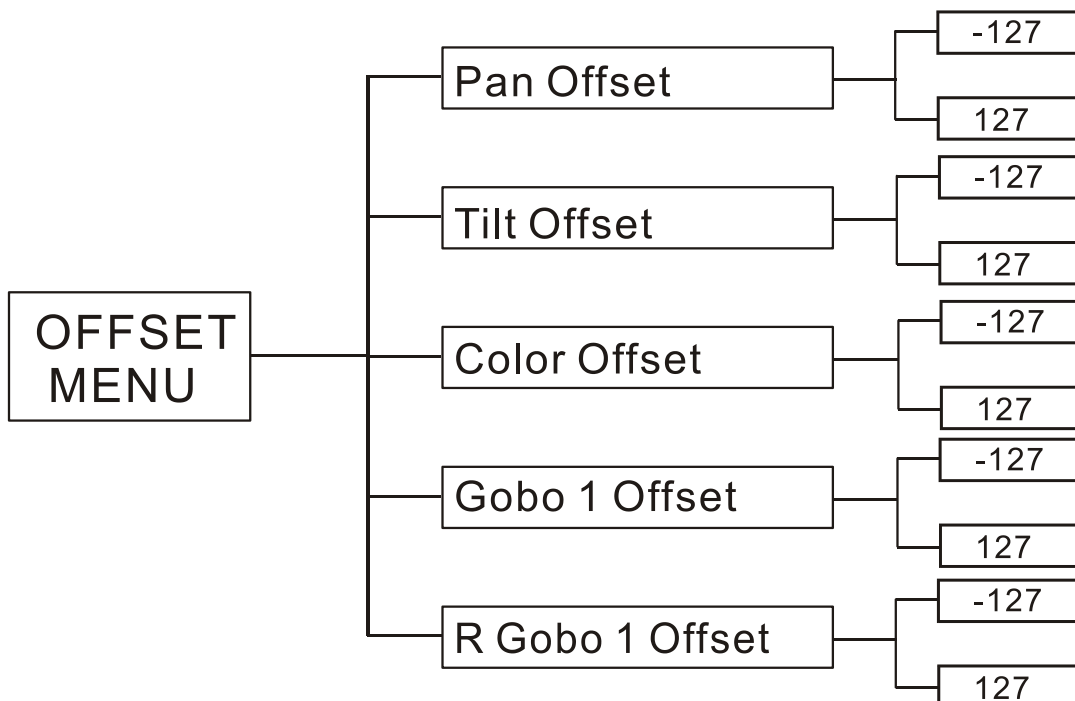

PAN OFFSET —Pan home position adjustment

To select the **Pan Offset**, press the **ENTER** button to show **PAN OFFSET** on the display. Use the **DOWN** and **UP** button to adjust the value from -127 to 127, press the **ENTER** button to store.

Press the **MENU** button to exit.

TILT OFFSET —Tilt home position adjustment

To select the **Tilt Offset**, press the **ENTER** button to show **TILT OFFSET** on the display. Use the **DOWN** and **UP** buttons to adjust the value from -127 to 127, press the **ENTER** button to store. Press the **MENU** button to exit.

COLOUR OFFSET —Color home position adjustment

To select the **Colour Offset**, press the **ENTER** button to show **COLOUR OFFSET** on the display. Use the **DOWN** and **UP** buttons to adjust the value from -127 to 127, press the **ENTER** button to store. Press the **MENU** button to exit.

GOBO 1 OFFSET —Gobo1 home position adjustment

To select the **Gobo 1 Offset**, press the **ENTER** button to show **GOBO 1 OFFSET** on the display. Use the **DOWN** and **UP** buttons to adjust the value from -127 to 127, press the **ENTER** button to store. Press the **MENU** button to exit.

R GOBO 1 OFFSET —Gobo1 rotation home position adjustment

To select the **R Gobo 1 Offset**, press the **ENTER** button to show **R GOBO 1 OFFSET** on the display. Use the **DOWN** and **UP** buttons to adjust the value from -127 to 127, press the **ENTER** button to store. Press the **MENU** button to exit.

4. How to Control the Unit

There are three ways to control the unit:

1. Master/slave built-in pre-program function
2. Easy controller (optional CA-8)
3. Universal DMX controller

You do not need to turn the unit off when you change the DMX address, the new DMX address setting will take effect immediately. Every time you power the unit on, it will move all the motors

to their 'home' position and you may hear some movement noises for about 20 seconds. After that the unit will be ready to receive a DMX signal or run the built in programs.

4.1 Master/Slave Built In Pre-program Function

By linking the units in master/slave connection, the first unit will control the other units to give an automatic, sound activated, synchronized light show. This function is very good when you want an instant show. You have to set the first unit in master mode **Show Mode** and select **show 1, show 2, show 3** or **show 4** mode. The DMX input socket will have nothing plugged into it, and the master LED will be constantly on and sound LED will flash to the music. The other units will need to be set in **slave mode** and select **Slave 1** (normal) or **Slave 2** (2 light show) mode, The units should be linked with DMX cables plugged into the DMX input jacks (daisy chain) and the slave LEDs will be constantly on.

2-light show

In slave mode, **Slave 1** means the unit works normally and **Slave 2** means 2-light show. In order to create a great light show, you can set **Slave 2** on the second unit to get contrast movement to each other, even if you have two units only.

4.2 Easy CA-8 Controller

The easy remote control is used only in master/slave mode. By connecting to the 1/4" jack socket of the first unit, you will find that the remote controller on the first unit will control all the other units in Stand by, and Mode selection.

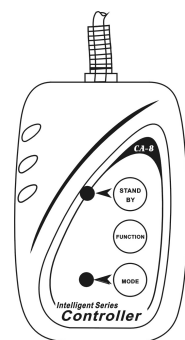

Stand By	Blackout the unit		
Function	1. Sync. Strobe 2. Async strobe 3. Sound Strobe	Show 1-4	1. Press to select colour 2. Hold to select gobo
Mode	Sound	Show	LED ON

	(LED OFF)	(LED Slow Blinking)	
--	-----------	---------------------	--

4.3 DMX Controller

By using a universal DMX controller to control the units, you need to set a DMX address from 1 to 512 so that the units can receive a DMX signal.

Press the **MENU** button up to when **DMX Address** is showing on the display. Press the **ENTER** button and the display will blink. Use the **DOWN** and **UP** buttons to change the DMX512 address.

Once the address has been selected, press and keep the **ENTER** button pressed up to when the display stops blinking or it will store automatically after 7 seconds. To go back to the functions without any change press the **MENU** button again.

Please refer to the following diagram to address your DMX512 channel for the first 4 units.

Channel mode	Unit 1 Address	Unit 2 Address	Unit 3 Address	Unit 4 Address
8 channels	1	9	17	25
11 channels	1	12	23	34

5. DMX512 Configuration

8 Channels Mode:

8 Channels Mode				
Ch1	Ch2	Ch3	Ch4	
Pan	Tilt	Shutter	Gobo	
<p>255 540°</p> <p>0 0°</p>	<p>255 270°</p> <p>0 0°</p>	<p>248-255 Open</p> <p>240-247 Random Strobe</p> <p>232-239 Open</p> <p>190-231 Fast Open Slow Close</p> <p>182-189 Open</p> <p>140-181 Fast Close Slow Open</p> <p>132-139 Open Fast</p> <p>016-131 </p> <p>008-015 Slow Open</p> <p>000-007 Blackout</p>	<p>255 Rotation Fast</p> <p>194 Rotation Slow</p> <p>190-193 Stop</p> <p>189 Rotation Slow</p> <p>128 Rotation Fast</p> <p>119-127 Gobo7 shaking</p> <p>110-118 Gobo6 shaking</p> <p>101-109 Gobo5 shaking</p> <p>092-100 Gobo4 shaking</p> <p>083-091 Gobo3 shaking</p> <p>074-082 Gobo2 shaking</p> <p>064-073 Gobo1 shaking</p> <p>056-063 Gobo7</p> <p>048-055 Gobo6</p> <p>040-047 Gobo5</p> <p>032-039 Gobo4</p> <p>024-031 Gobo3</p> <p>016-023 Gobo2</p> <p>008-015 Gobo1</p> <p>000-007 Open</p>	
Ch5		Ch6	Ch7	Ch8
Color Wheel (Normal)	Color Wheel (Split Color Mode)	R-Gobo	Dimmer	Function
<p>255 Rotation Fast</p> <p>194 Rotation Slow</p> <p>190-193 Stop</p> <p>189 Rotation Slow</p> <p>128 Rotation Fast</p> <p>113-127 Pink</p> <p>099-112 Light Blue</p> <p>085-098 Magenta</p> <p>071-084 Blue</p> <p>057-070 Green</p> <p>043-056 Yellow</p> <p>029-042 Orange</p> <p>015-028 Red</p> <p>000-014 White</p>	<p>255 Rotation Fast</p> <p>194 Rotation Slow</p> <p>190-193 Stop</p> <p>189 Rotation Slow</p> <p>128 Rotation Fast</p> <p>120-127 Pink</p> <p>113-119 Light Blue + Pink</p> <p>105-112 Light Blue</p> <p>098-104 Magenta + Light Blue</p> <p>090-097 Magenta</p> <p>083-089 Blue + Magenta</p> <p>075-082 Blue</p> <p>068-074 Green + Blue</p> <p>060-067 Green</p> <p>053-059 Yellow + Green</p> <p>045-052 Yellow</p> <p>038-044 Orange + Yellow</p> <p>030-037 Orange</p> <p>023-029 Red + Orange</p> <p>015-022 Red</p> <p>008-014 White + Red</p> <p>000-007 White</p>	<p>255 Rotation Fast</p> <p>194 Rotation Slow</p> <p>190-193 Stop</p> <p>189 Rotation Slow</p> <p>128 Rotation Fast</p> <p>000-127 Index 0° ~360°</p>	<p>255 100%</p> <p>0 0%</p>	<p>250-255 Sound Active</p> <p>210-249 No Function</p> <p>200-209 Reset All</p> <p>130-199 No function</p> <p>120-129 Disable blackout while Gobo changing</p> <p>110-119 Enable blackout while Gobo changing</p> <p>100-109 Disable blackout while Color changing</p> <p>090-099 Enable blackout while Color changing</p> <p>080-089 Disable blackout while Pan/Tilt moving</p> <p>070-079 Enable blackout while Pan/Tilt moving</p> <p>000-069 No Function</p>

11 Channels Mode:

11 Channels Mode						
Ch1	Ch2	Ch3	Ch4	Ch5	Ch6	Ch7
Pan	Pan Fine	Tilt	Tilt Fine	Pan/Tilt Speed	Dimmer	Shutter
255 540° 0 0°	255 0	255 270° 0 0°	255 0	255 Slow 0 Fast	255 100% 0 0%	248-255 Open 240-247 Random Strobe 232-239 Open 190-231 Fast Open Slow Close 182-189 Open 140-181 Fast Close Slow Open 132-139 Open Fast 016-131 008-015 Slow Open 000-007 Blackout
Ch8		Ch9	Ch10	Ch11		
Color Wheel (Normal)	Color Wheel (Split Color Mode)	Gobo	R-Gobo	Function		
255 Rotation Fast 194 Rotation Slow 190-193 Stop 189 Rotation Slow 128 Rotation Fast 113-127 Pink 099-112 Light Blue 085-098 Magenta 071-084 Blue 057-070 Green 043-056 Yellow 029-042 Orange 015-028 Red 000-014 White	255 Rotation Fast 194 Rotation Slow 190-193 Stop 189 Rotation Slow 128 Rotation Fast 120-127 Pink 113-119 Light Blue + Pink 105-112 Light Blue 098-104 Magenta + Light Blue 090-097 Magenta 083-089 Blue + Magenta 075-082 Blue 068-074 Green + Blue 060-067 Green 053-059 Yellow + Green 045-052 Yellow 038-044 Orange + Yellow 030-037 Orange 023-029 Red + Orange 015-022 Red 008-014 White + Red 000-007 White	255 Rotation Fast 194 Rotation Slow 190-193 Stop 189 Rotation Slow 128 Rotation Fast 119-127 Gobo7 shaking 110-118 Gobo6 shaking 101-109 Gobo5 shaking 092-100 Gobo4 shaking 083-091 Gobo3 shaking 074-082 Gobo2 shaking 064-073 Gobo1 shaking 056-063 Gobo7 048-055 Gobo6 040-047 Gobo5 032-039 Gobo4 024-031 Gobo3 016-023 Gobo2 008-015 Gobo1 000-007 Open	255 Rotation Fast 194 Rotation Slow 190-193 Stop 189 Rotation Slow 128 Rotation Fast 000-127 Index 0° ~360°	250-255 Sound Active 210-249 No Function 200-209 Reset All 130-199 No function 120-129 Disable blackout while Gobo changing 110-119 Enable blackout while Gobo changing 100-109 Disable blackout while Color changing 090-099 Enable blackout while Color changing 080-089 Disable blackout while Pan/Tilt moving 070-079 Enable blackout while Pan/Tilt moving 000-069 No Function		



6. DMX Connection

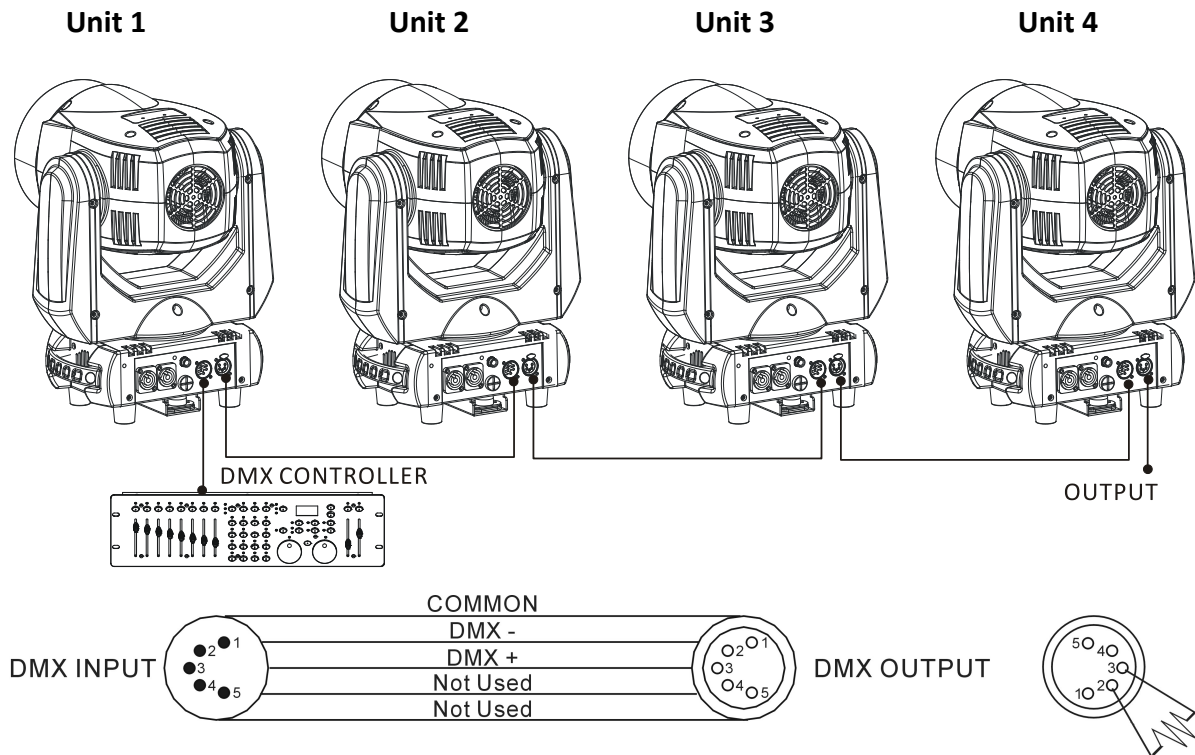

ATTENTION

Termination reduces signal errors and to avoid signal transmission problems and interference. It is always advisable to connect a DMX terminal (Resistance 120 ohm 1/4W between pin2 (DMX-) and pin3 (DMX+) of the last fixture).

1. The last units DMX output socket has to be terminated with a 120 ohm 1/4W resistor between pin 2(DMX-) and pin 3(DMX+) of a 3-pin XLR-plug.
2. Connect the units together in a `daisy chain` using the XLR plug from the output of the unit to the input of the next unit. The cable can not branched or split to a `Y` cable.
3. The DMX output and input connectors are pass-through to maintain the DMX circuit, even when the power is disconnected to the unit.
4. Each fixture unit needs to have an address set to receive the data sent by the controller. The address number is between 0-511 (usually 0 & 1 are equal to 1).

7. Troubleshooting

Following are a few common problems that may occur during operation. Here are some suggestions for easy troubleshooting:

A. The fixture does not work, no light output

1. Check the connection of power and the main fuse.

B. Not responding to DMX controller

1. DMX LED should be on. If not, check DMX connectors and cables to see if linked properly.
2. If the DMX LED is on and no response to the controller, check the address settings and DMX polarity.
3. If you have intermittent DMX signal problems, check cables and connectors on the fixture or the previous one.
4. Try another DMX controller.

C. Some fixtures don't respond to the easy controller

1. You may have a break in the DMX cabling. Check the LED for the response of the master/slave mode signal.
2. Wrong DMX address in the unit. Set the correct address.

D. No response to the sound

1. Make sure the fixture is not receiving a DMX signal.
2. Check the microphone by tapping it.
3. Make sure the fixture is not set into Blackout mode

8. Fixture Cleaning

The cleaning must be carried out periodically to optimize light output. Cleaning frequency depends on the environment in which the fixture operates: moist, smoky or particularly dirty surrounding can cause greater accumulation of dirt on the fixture.

- Clean with soft cloth using normal glass cleaning fluid.
- Always dry the parts carefully.
- Clean the external optics at least every 30 days.

Declaration of Conformity

We declare that our products (lighting equipments) comply with the following specification and bears CE mark in accordance with the provision of the Electromagnetic Compatibility (EMC) Directive 89/336/EEC.

EN55103-1: 2009 ; EN55103-2: 2009; EN62471: 2008;
EN61000-3-2: 2006 + A1:2009 + A2:2009; EN61000-3-3: 2008.

&

Harmonized Standard

EN 60598-1:2008 + All:2009; EN 60598-2-17:1989 + A2:1991;
EN 62471:2008; EN 62493: 2010
Safety of household and similar electrical appliances
Part 1: General requirements

Innovation, Quality, Performance